

DATE	REV	ECN	APP'D. BY
1-19-15	A6	10212	TRM
2-25-16	A7	10567	TRM
7-14-23	B0	12211	JE

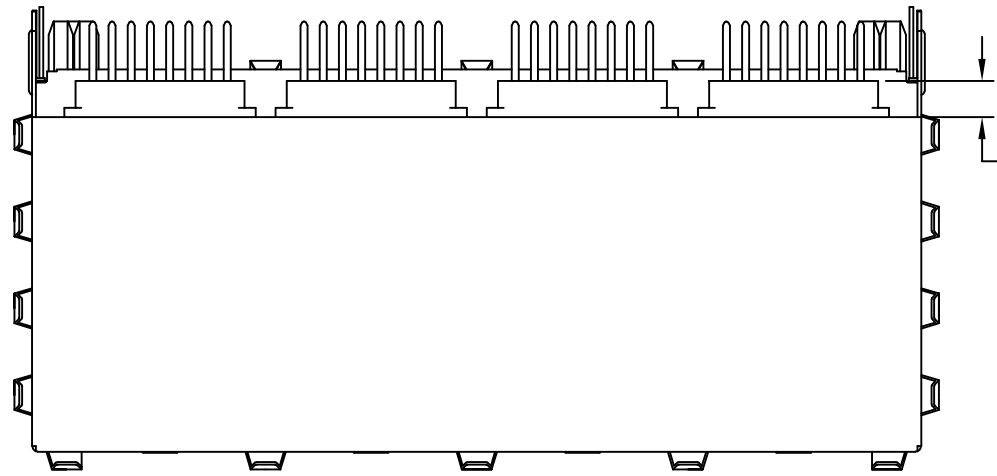
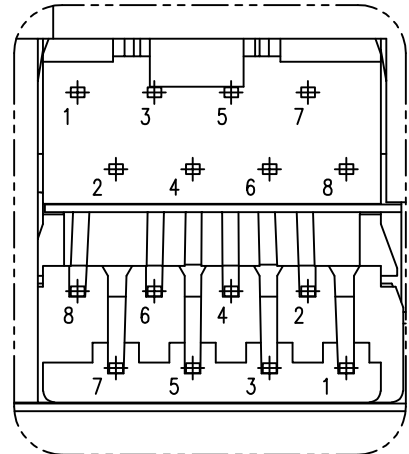
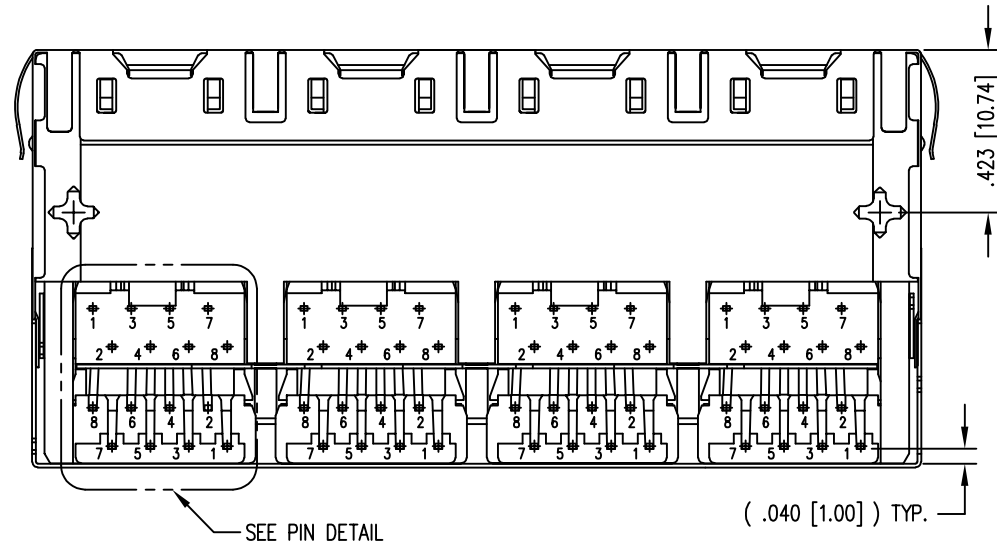
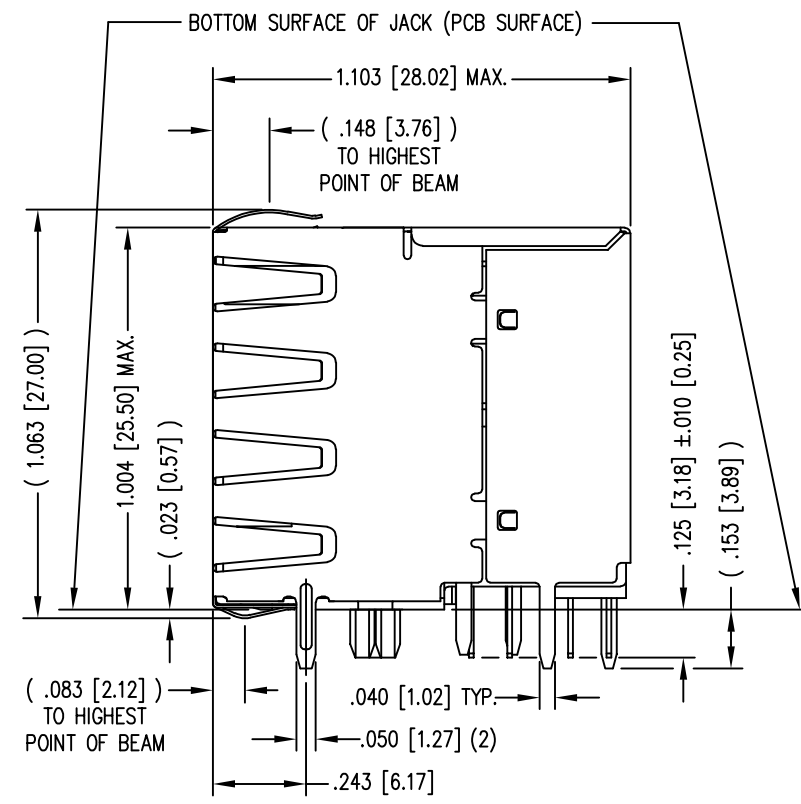
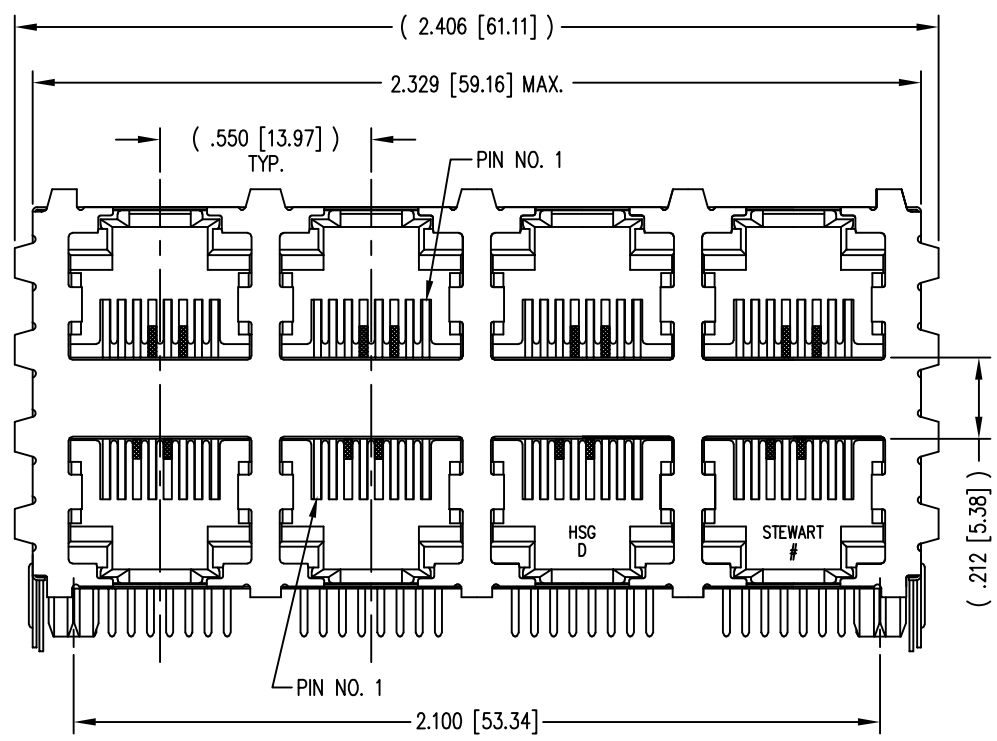

- NOTES:
- CONNECTOR MATERIALS:
HOUSING: THERMOPLASTIC UL94 V-0
CONTACTS/SHIELD: COPPER ALLOY
CONTACT PLATING: SELECTIVE GOLD IN CONTACT AREA
SEE CHART FOR PART NUMBER
SHIELD PLATING: NICKEL OR TIN
 - FOR PRODUCT SPECIFICATION SEE PRO22-01.
 - DIMENSIONS AND TOLERANCES COMPLY WITH FCC/CFR 47, PART 68.
 - THE SUGGESTED PANEL OPENING IS INTENDED TO GIVE USER THE ABILITY TO HAVE REASONABLE JACK/PANEL CLEARANCES, YET MAINTAIN GROUNDING CAPABILITY. THESE VARIABLES CAN BE ADJUSTED IN EITHER DIRECTION BUT MAY CARRY SOME CONSEQUENCES IN THE FORM OF LOWER MATING FORCES OR TIGHTER ASSEMBLY TOLERANCES.
 - DESIGNED FOR CATEGORY 5/5e APPLICATIONS.

50 MICRO-INCHES [1.27um]	SS-73100-002
CONTACT PLATING IN MATING AREA	PART NUMBER

THIRD ANGLE PROJECTION 	 stewart CONNECTOR a bel group	1118 Susquehanna Trail South Glen Rock, PA 17327-9199 (717) 235-7512 http://www.stewartconnector.com
DO NOT SCALE DRAWING DRAWING IS SUBJECT TO CHANGE WITHOUT NOTICE	TITLE: EIGHT CONTACT, EIGHT POSITION SHIELDED STACK JACK ENHANCED SHIELD, 8 PORT (4 ON 4)	
DIMENSIONS: INCHES [METRIC] UNLESS OTHERWISE SPECIFIED TOLERANCES ARE ±.005 [0.13] ANGLES ARE ± 1°	THIS DRAWING AND THE SUBJECT MATTER SHOWN THEREON ARE CONFIDENTIAL AND THE PROPRIETARY PROPERTY OF STEWART CONNECTOR AND SHALL NOT BE REPRODUCED, COPIED, OR USED IN ANY MANNER WITHOUT PRIOR WRITTEN CONSENT OF STEWART CONNECTOR. ONE OR MORE U.S. PATENTS MAY APPLY TO THIS PRODUCT. FOR DETAILS, PLEASE VISIT: HTTP://BELFUSE.COM/STEWART/STEWART_PATENTS/	DRN BY: TRM DATE 3-28-03 APPD BY: RGC DATE 4-2-03
SHEET NO. 1 OF 2		DWG NO. CT730052 REV. B0



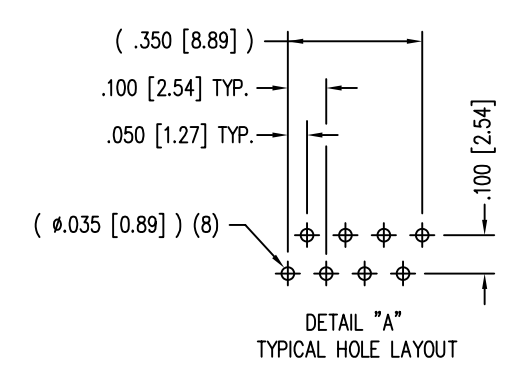
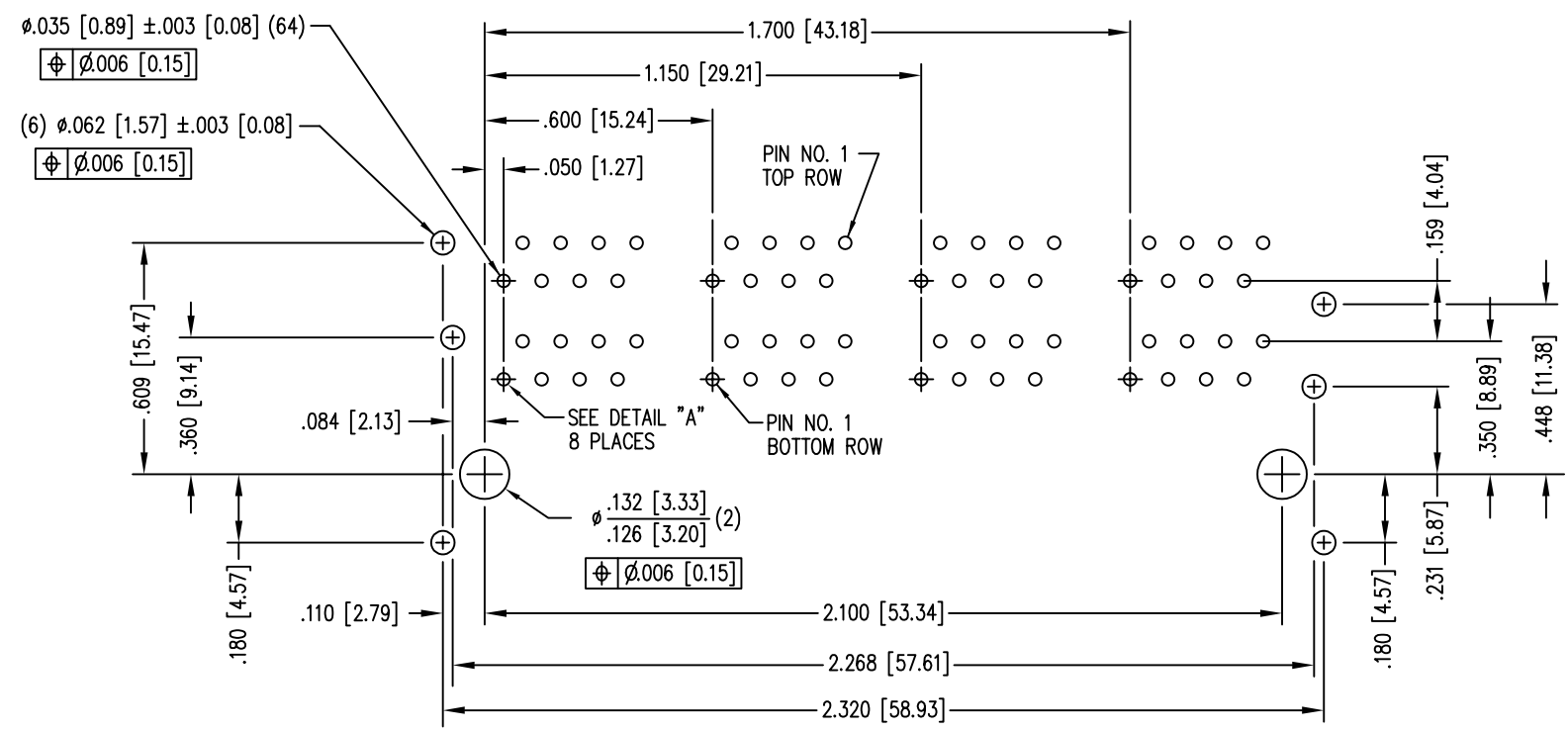

P.C.B. RECOMMENDED HOLE LAYOUT
SEEN FROM COMPONENT SIDE
ALL CENTERLINE DIMENSIONS ARE BASIC.

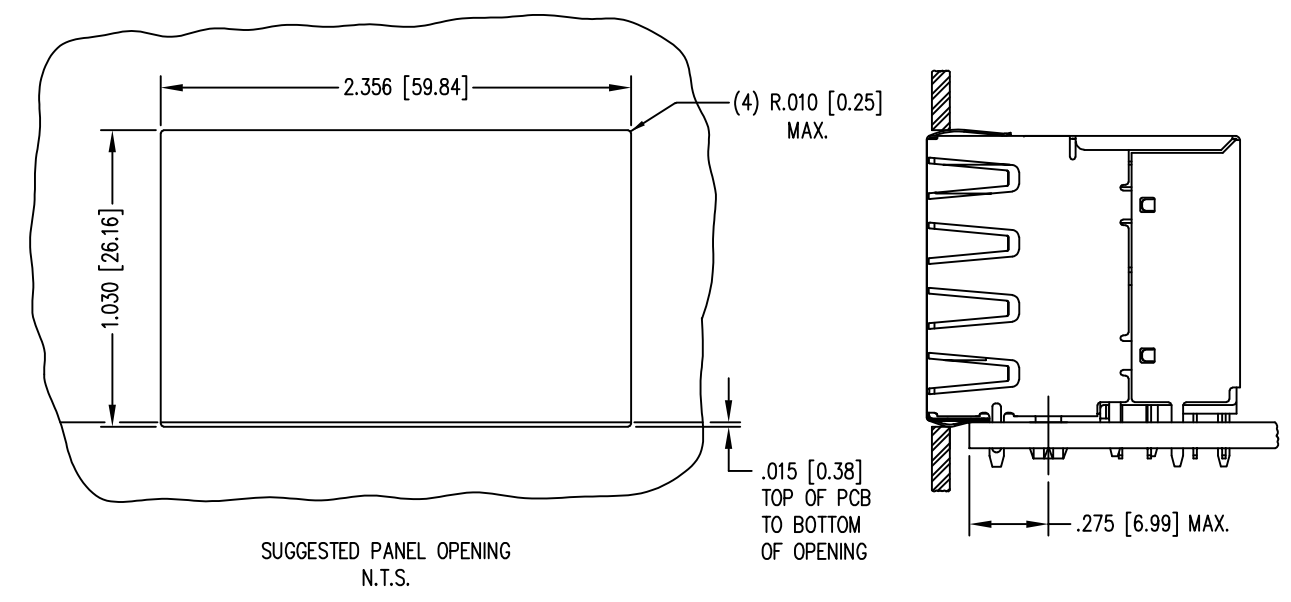

THIRD ANGLE PROJECTION 	 stewart CONNECTOR a bel group	11118 Susquehanna Trail South Glen Rock, PA 17327-9199 (717) 235-7512 http://www.stewartconnector.com
DO NOT SCALE DRAWING DRAWING IS SUBJECT TO CHANGE WITHOUT NOTICE	TITLE: EIGHT CONTACT, EIGHT POSITION SHIELDED STACK JACK ENHANCED SHIELD, 8 PORT (4 ON 4)	
DIMENSIONS: INCHES [METRIC]	DRN BY: TRM	DATE: 3-28-03
UNLESS OTHERWISE SPECIFIED TOLERANCES ARE ±.005 [0.13] ANGLES ARE ± 1°	APPD BY: RGC	DATE: 4-2-03
SHEET NO. 2 OF 2	DWG NO. CT730052	REV. B0