

Assembly Instructions

1) Strip the cable to the dimensions shown.

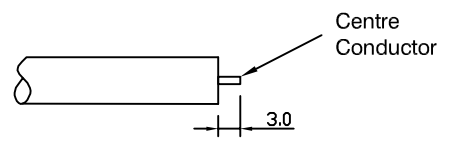

2) Fit Insulator Onto Centre Conductor.
Solder The Contact On To The Centre Conductor.

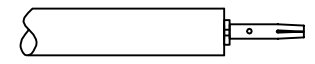

3) Insert Insulator Into Body Using Insertion Tool For Jacks Or A Mating Connector

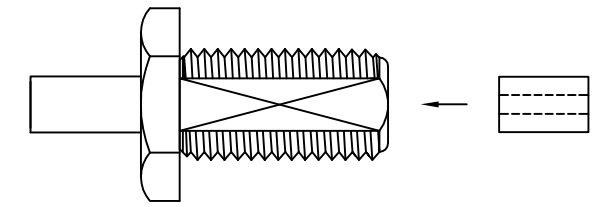

3) Slide The Body On To The Cable And Mate With Connector.

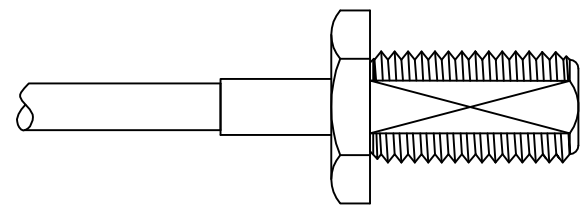

4) Solder Around The Top Of The Mandrel Using Soldering Tongs Or Thermal Resistance Tweezers.

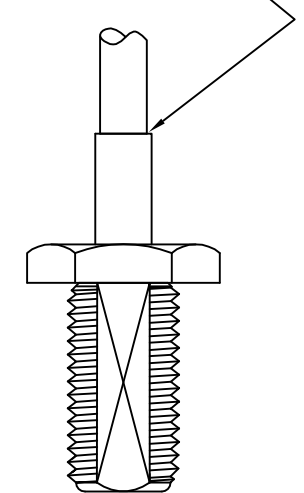

First Issue	MT	1	21 Jul 05
DESCRIPTION OF REVISION	APPVD	ISS	DATE



Cinch Connectivity Solutions, Ltd
11 Bilton Road
Chelmsford
Essex CM1 2UP, England
T: +44 (0) 1245 342060
F: +44 124 535 8938

SCALE: Not To Scale	DRAWN BY:	M Terry
DIMENSIONS: mm	CHECKED BY:	J Williams
TOLERANCES: ± 0.2mm unless otherwise stated	APPROVED BY:	M Terry
	DATE:	21 Jul 05

TITLE:
**Stripping and Assembly
Instructions for SMA Solder
Bulkhead Jack RG402/RG405
Semi Rigid And Conformable
Cable**

PART NUMBER: VAIS4401
PAGE: 1 of 1