

DATE	REV	ECN	APP'D. BY
06/12/19	A0	Released	AB
08/06/19	A1	11432	AB

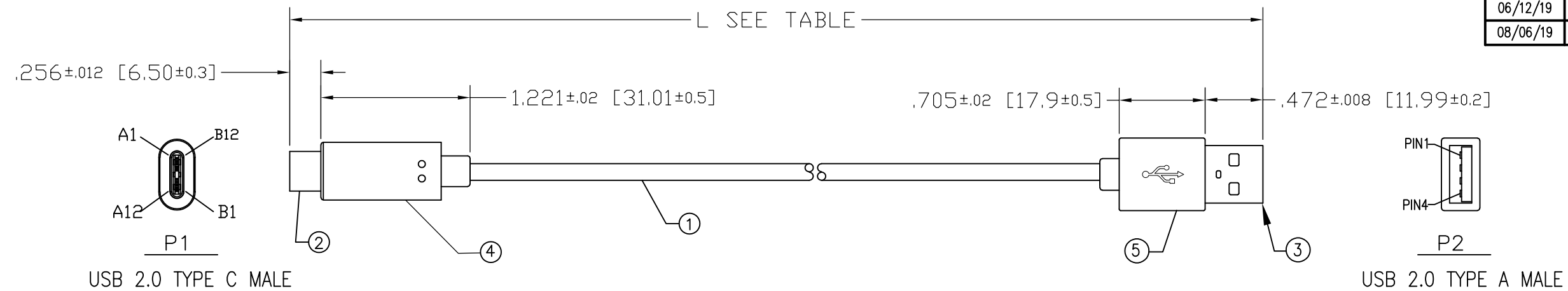

P/N Key:

SC-2CAKxxxM  
 Length  
 010 = 1 Meter  
 020 = 2 Meter

Notes:

- Cable:  
 USB 2.0 CABLE, UL STYLE 1  
 -28AWG 1 TWISTED PAIR  
 -26AWG X 2C  
 -OD 4.5mm  
 -JACKET BLACK,
- Connector P1:  
 USB 2.0 C MALE , GOLD FLASH ON CONTACTS, WITH PCB, BLACK INSULATOR  
 RESISTANCE 56K ohm
- Connector P2:  
 USB A MALE, GOLD FLASH ON CONTACTS, WHITE INSULATOR, SHORT THREE PIECES TYPE
- USB Type C Over-Molded PVC Color: Black
- USB Type A Over-Molded PVC Color: Black
- Electrical Test:  
 6.1. 100%Test(Open ,short ,Wire Map)
- Packaging: Each cable assembly to be individually bagged

PIN ASSIGNMENT			
P1		P2	
A4+B4+A9+B9	—	1 RED	26 AWG
A7	—	2 WHITE	
A6	—	3 GREEN	
A1+B1+A12+B12	—	4 BLACK	26AWG
SHIELD	—	SHIELD	

Example Parts Numbers

Meter	
P/N	Dim L
SC-2CAK010M	1000 mm ±30mm
SC-2CAK020M	2000 mm ±30mm

For Part Numbers Not Shown Follow Part Number Key Format

THIRD ANGLE PROJECTION

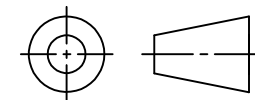

DO NOT SCALE DRAWING  
 DRAWING IS SUBJECT TO  
 CHANGE WITHOUT NOTICE

DIMENSIONS: INCHES [METRIC]

UNLESS OTHERWISE SPECIFIED  
 TOLERANCES ARE ±.005 [0.13]  
 ANGLES ARE ± 1°

SHEET NO. 1 OF 1

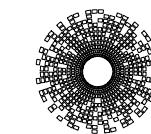

**stewart**  
 CONNECTOR  
 a bel group

11118 Susquehanna Trail South  
 Glen Rock, PA 17327-9199  
 (717) 235-7512

<http://www.stewartconnector.com>

TITLE: Cable Assembly, USB 2.0, Type C/M – Type A/M, Black

THIS DRAWING AND THE SUBJECT MATTER SHOWN THEREON  
 ARE CONFIDENTIAL AND THE PROPRIETARY PROPERTY OF  
 STEWART CONNECTOR AND SHALL NOT BE REPRODUCED,  
 COPIED, OR USED IN ANY MANNER WITHOUT PRIOR WRITTEN  
 CONSENT OF STEWART CONNECTOR.

DRN BY:	GWL	DATE	05/30/19
APPD BY:	AB	DATE	06/12/19
DWG NO.	CT999194	REV.	A1