

THIS DRAWING AND THE SUBJECT MATTER SHOWN THEREON ARE CONFIDENTIAL AND THE PROPERTY OF BEL/STEWART/TRP CONNECTOR AND SHALL NOT BE REPRODUCED, COPIED, OR USED IN ANY MANNER WITHOUT THE WRITTEN CONSENT OF TRP CONNECTOR.

PRODUCT MAY BE PROTECTED BY ONE OR MORE OF THE FOLLOWING US PATENTS:
 5736910 5939955 6425781 6428361 6554638 6840817 7123117
 7429195 7717749 7808751 6217391 6149050 7924130

REVISIONS				
P	LTN	DESCRIPTION	DATE	APPD
4		SEE LAST SHEET	14JAN2015	RL TY

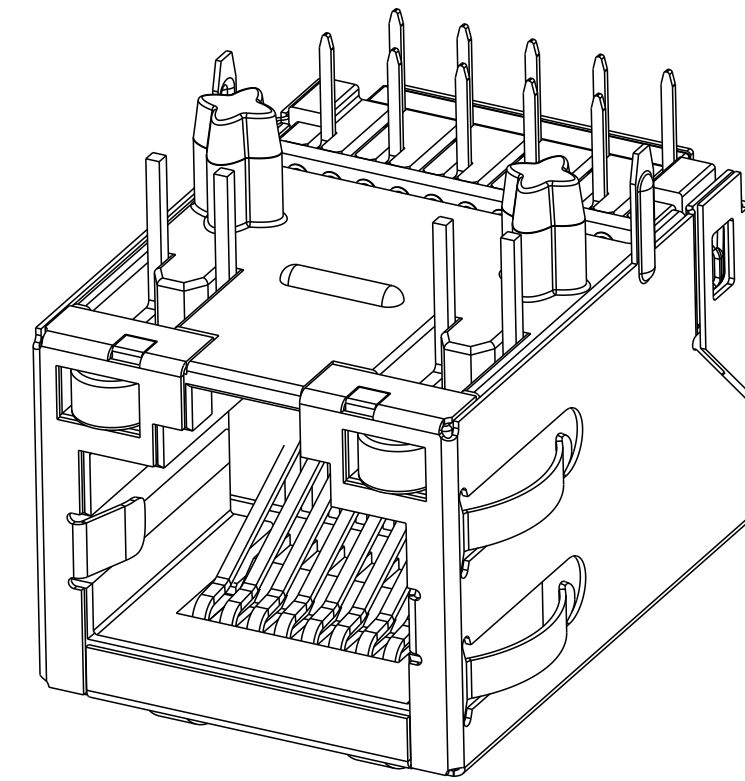
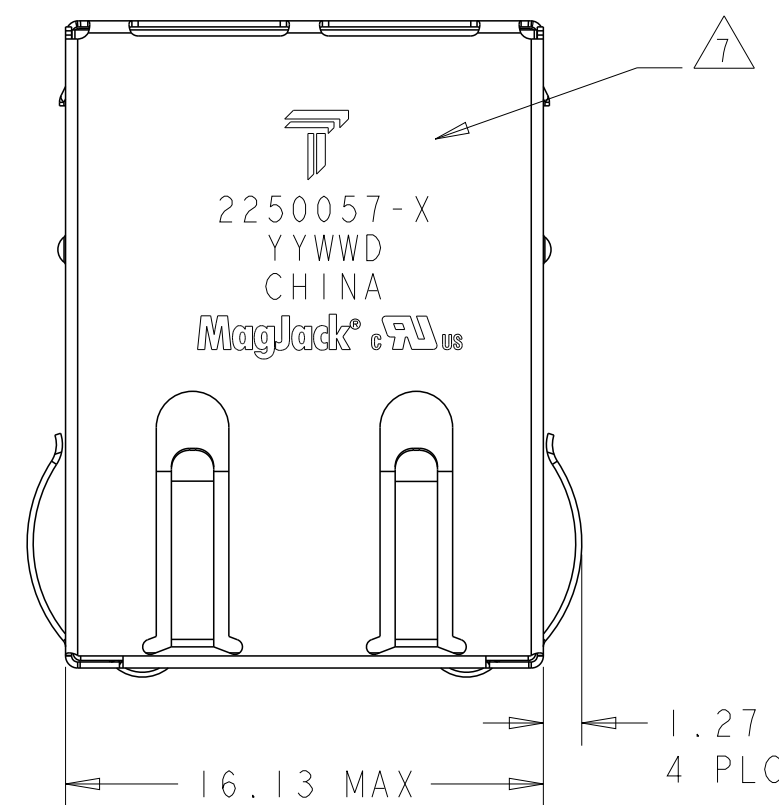

1. MATERIALS
- HOUSING: THERMOPLASTIC, FLAMMABILITY RATING UL 94V-0.
 - SHIELD: BRASS 0.20mm THICK, PREPLATED WITH 0.76um MIN SEMI-BRIGHT NICKEL. SOLDER TABS POST DIPPED WITH 2.54um MIN SAC SOLDER.
 - CONTACTS: PHOSPHOR BRONZE 0.46mm X 0.30mm, PHOSPHOR BRONZE, 1.27um MIN NICKEL UNDERPLATE, WITH 1.27um MIN GOLD PLATING AT MATING INTERFACE AND 2.54um MIN MATTE TIN ON SOLDER TAILS.
 - SOLDER TAILS: 0.25mm THICK, PHOSPHOR BRONZE, 1.27um MIN OVERALL NICKEL UNDERPLATE, 3um TIN PLATE
 - LIGHT EMITTING DIODE (LED): DIFFUSED EPOXY LENS, 0.5mm X 0.5mm CARBON STEEL WIREFRAME LEADS PREPLATED WITH 2.03um MIN. SILVER PLATE OVER 1.02um MIN. NICKEL OVER 1.02um MIN. COPPER UNDERPLATE; LEADS POST-PLATED WITH 3.05um MIN. MATTE TIN AND/OR SAC SOLDER DIP OR PURE TIN SOLDER DIP

2. RJ45 JACK CAVITY CONFORMS TO FCC RULES AND REGULATIONS PART 68 SUB PART F.

3. MAGNETICS
- APPLICATION: 10/100 BASE-T, PoE
 - IMPEDANCE: 100 OHMS
 - TURNS RATIO (CHIP:CABLE): TX = 1:1, RX = 1:1
 - OPEN CIRCUIT INDUCTANCE (OCL): 350uH MIN @100kHz, 0.1VRMS, 8mADC BIAS FROM -40°C TO +85°C, TX AND RX
 - POE CURRENT: 350mADC MAX
 - PERFORMANCE @ 25°C:
 - INSERTION LOSS (IL): 1.1dB MAX FROM 0.5MHz TO 100MHz
 - RETURN LOSS (RL): 18dB MIN FROM 0.5MHz TO 30MHz
 - 18-20LOG(f/30)dB MIN FROM 30.1MHz TO 60MHz
 - 12dB MIN FROM 60.1MHz TO 80MHz
 - CROSSTALK ATTENUATION: 35dB MIN FROM 0.5MHz TO 40MHz
 - 33-20LOG(f/50)dB MIN FROM 40.1MHz TO 100MHz
 - COMMON MODE REJECTION RATIO (CMRR): 30dB MIN FROM 0.5MHz TO 100MHz
 - ISOLATION VOLTAGE: 2250VDC FOR 60 SECONDS WITH A RISE TIME OF 500 V/SEC

4. OPERATING TEMPERATURE: FROM -40°C TO +85°C.

5. INDICATED MAGNETIC CONNECTIONS ARE SYMMETRICAL TO SUPPORT AUTO-MDI/MDIX.

6. LEDS ARE DRIVEN WITH CONSTANT CURRENT AT APPROX 20mA
- LED COLOR: DOMINATE WAVELENGTH (λD): GREEN 568 nm TYP. AT IF = 20mA
 FORWARD VOLTAGE (VF): GREEN 2.2V TYP. at IF = 20mA
 DOMINATE WAVELENGTH (λD): ORANGE 605 nm TYP. AT IF = 20mA
 FORWARD VOLTAGE (VF): ORANGE 2.1V TYP. at IF = 20mA
 DOMINATE WAVELENGTH (λD): RED 640 nm TYP. AT IF = 20mA
 FORWARD VOLTAGE (VF): RED 2.2V TYP. at IF = 20mA

7. TRP CONNECTOR LOGO, PART NUMBER, DATE CODE, COUNTRY OF ORIGIN AND AGENCY APPROVAL MARKING IN APPROXIMATE LOCATION SHOWN.

8. THESE PARTS ARE RECOMMENDED FOR WAVE SOLDERING PROCESS, PREHEAT TEMPERATURE IS 120°C TO 160°C, 120 SECONDS TO 180 SECONDS, PEAK WAVE SOLDERING TEMPERATURE IS 260°C MAX, 10 SECONDS MAX.

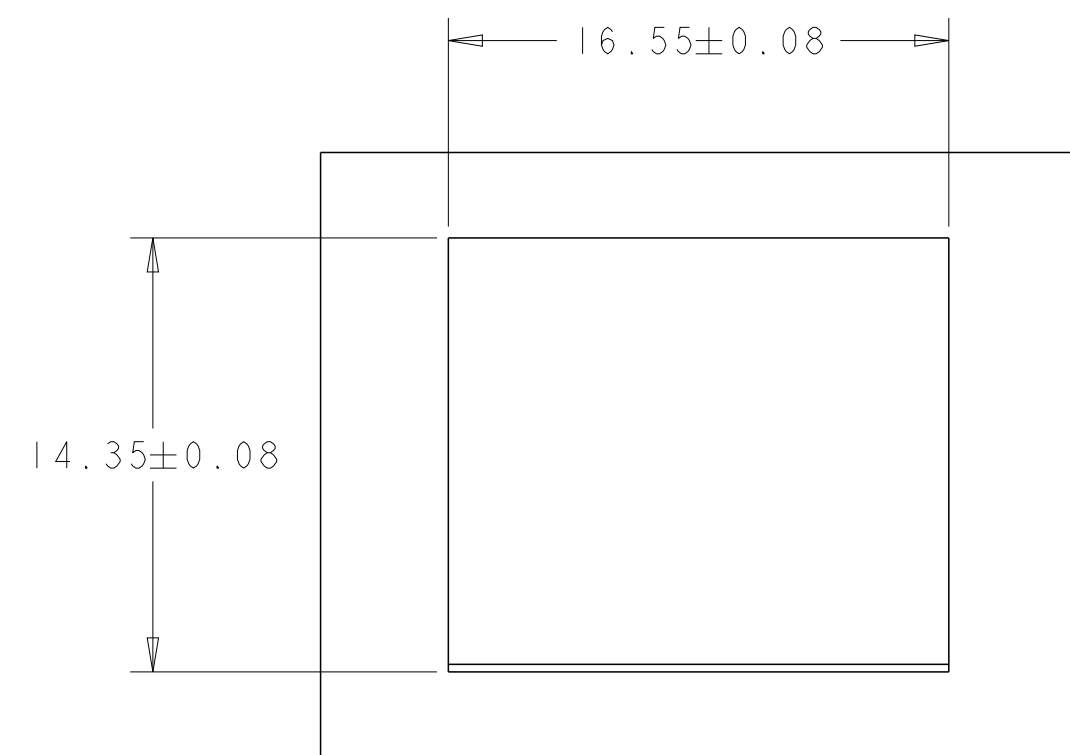
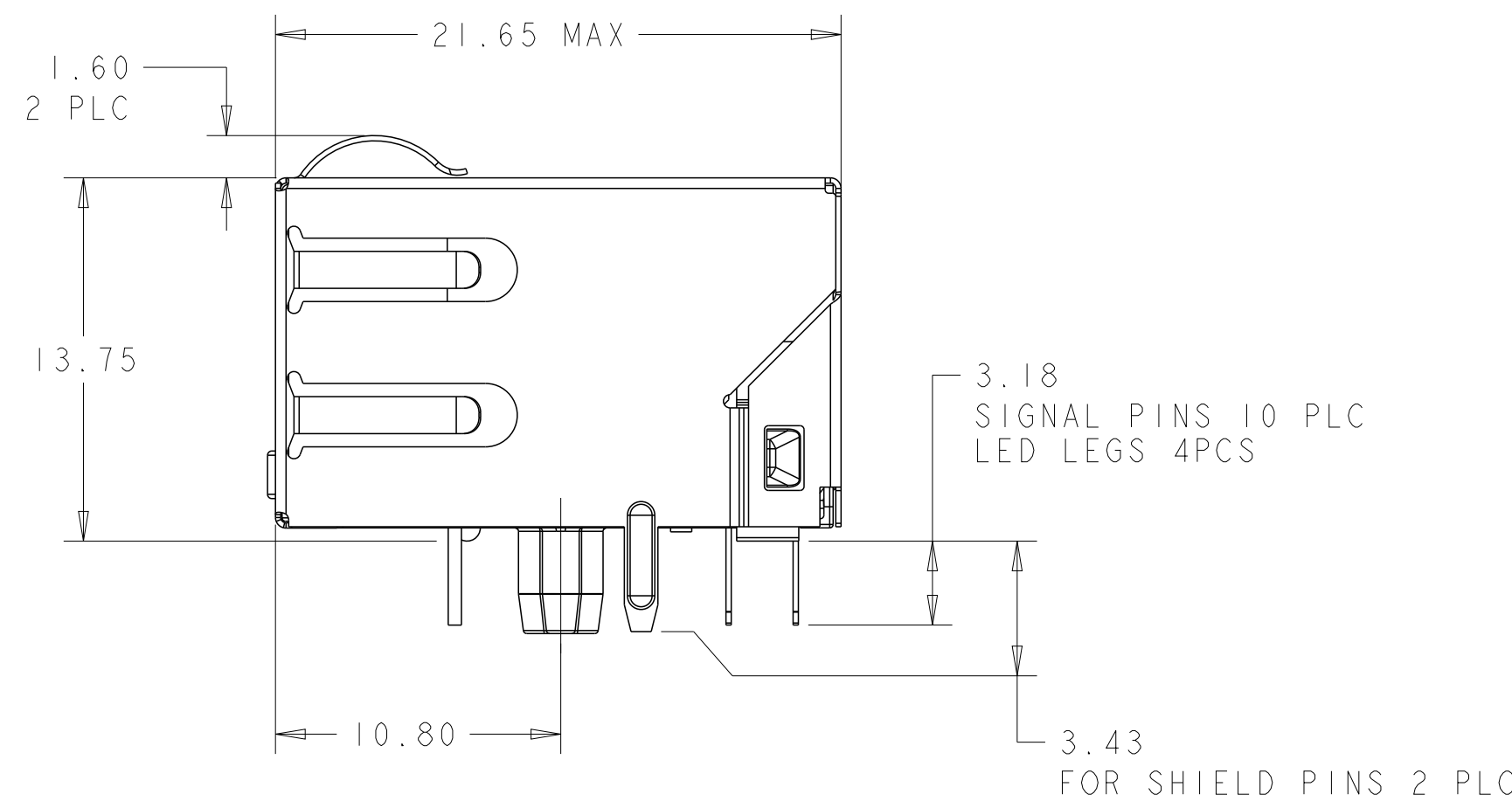
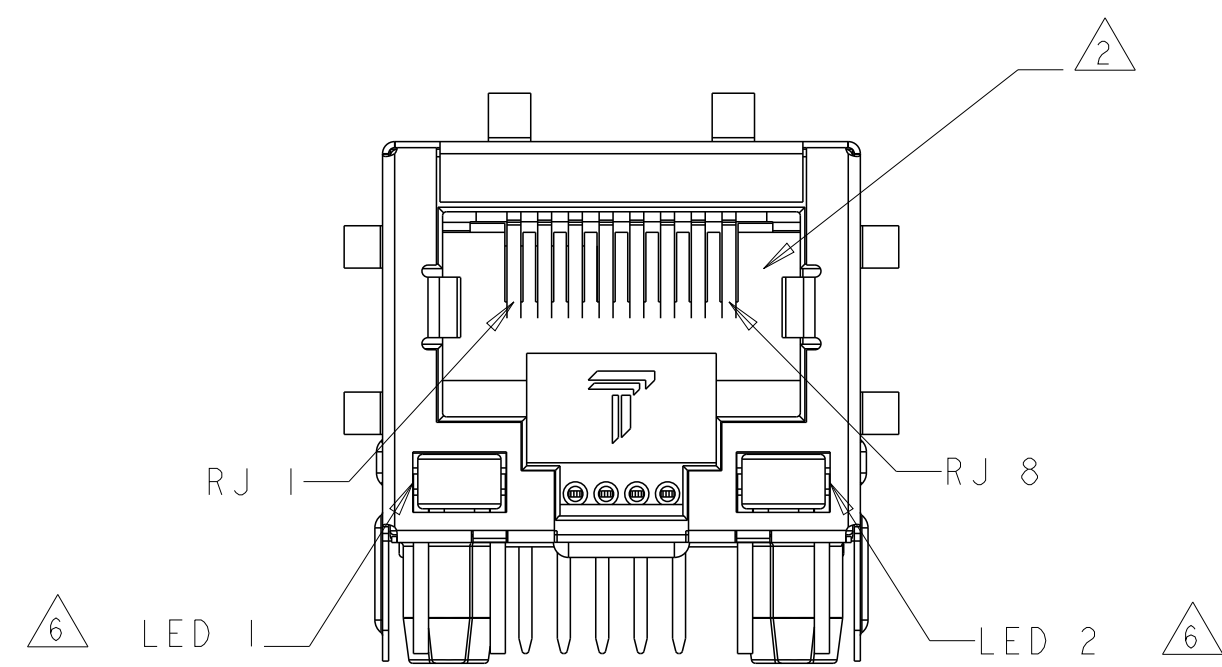

SUGGESTED PANEL CUTOUT
 SCALE 4:1

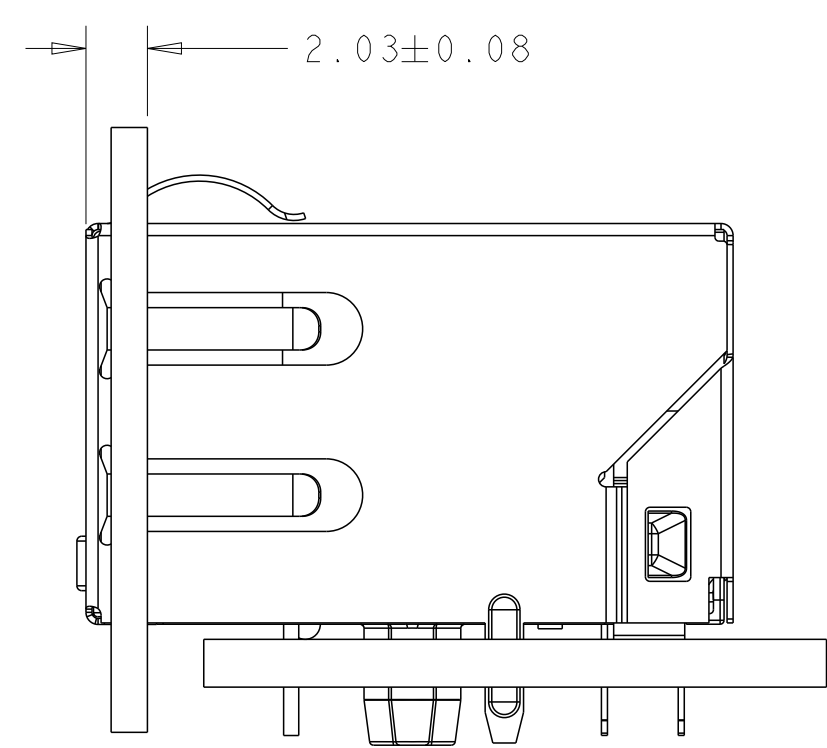

GREEN	RED	2250057-2
GREEN	ORANGE	2250057-1
11-12	13-14	PART NUMBER
LED 1	LED 2	

THIS DRAWING IS A CONTROLLED DOCUMENT.		OWN ROY LIU 06 JUN 2013	 TRP CONNECTOR a bel group DONGGUAN CHINA
DIMENSIONS: mm		CHK TOWER YU/ FRANK LIU 06 JUN 2013	
TOLERANCES UNLESS OTHERWISE SPECIFIED:		APPD TONY YUAN 06 JUN 2013	MODEL NAME
0 PLC ±0.25 1 PLC ±0.25 2 PLC ±0.25 3 PLC ±0.25 4 PLC ±0.25 ANGLES ±° APPLICATION SPEC ±°		PRODUCT SPEC 108-104004	DESC 1X1 4D26LET 10/100 POE TAB DOWN W/ LED
DIMENSIONS: mm TOLERANCES UNLESS OTHERWISE SPECIFIED:		SIZE A1	RESTRICTED TO
DIMENSIONS: mm TOLERANCES UNLESS OTHERWISE SPECIFIED:		SCALE 4:1	SHEET 1 OF 3
DIMENSIONS: mm TOLERANCES UNLESS OTHERWISE SPECIFIED:		CUSTOMER DRAWING	REV 4

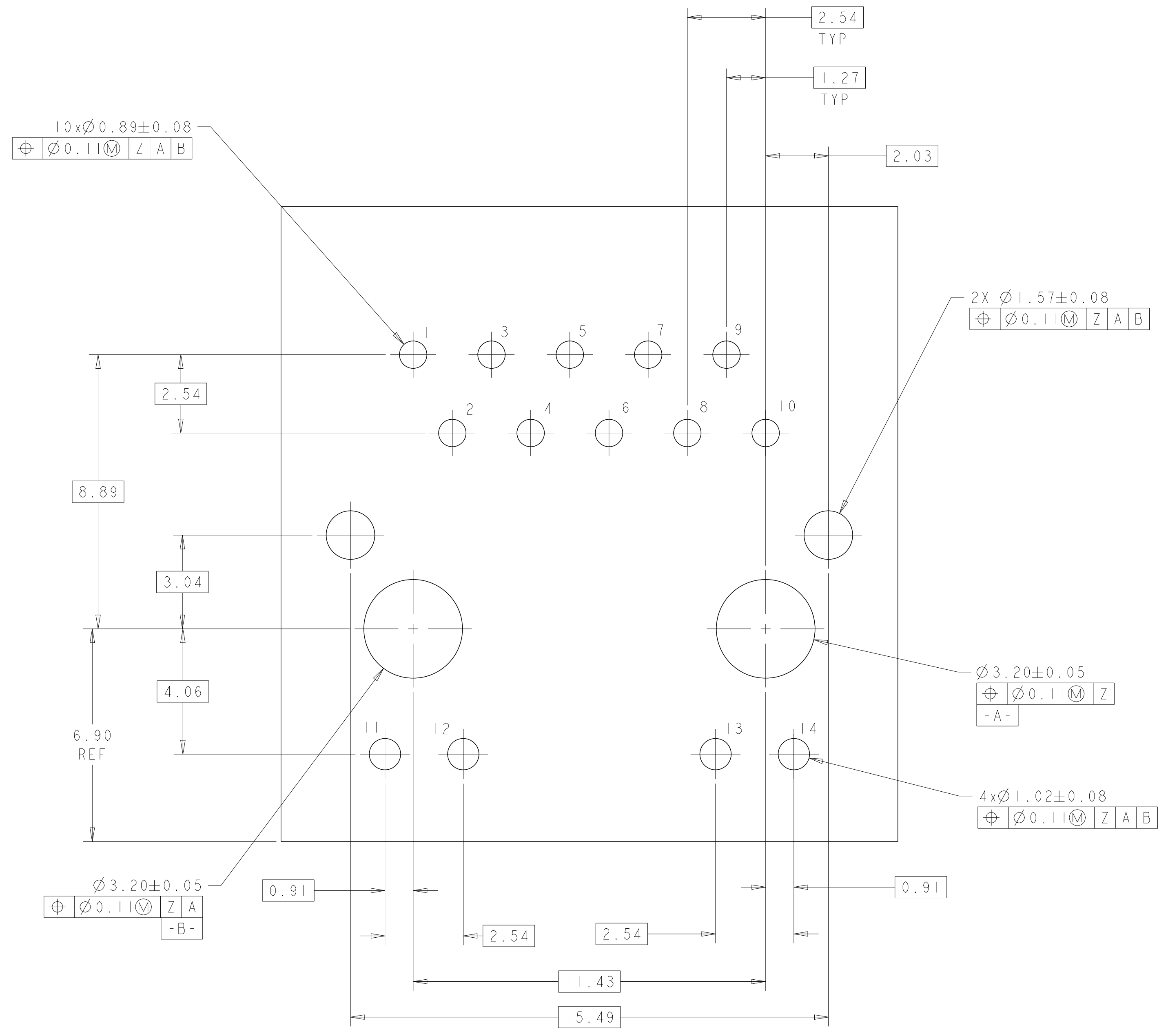

SUGGESTED PCB LAYOUT
 COMPONENT SIDE

4D26LET PoE 10/100 BASE-T CIRCUIT $\triangle 3 \triangle 5$

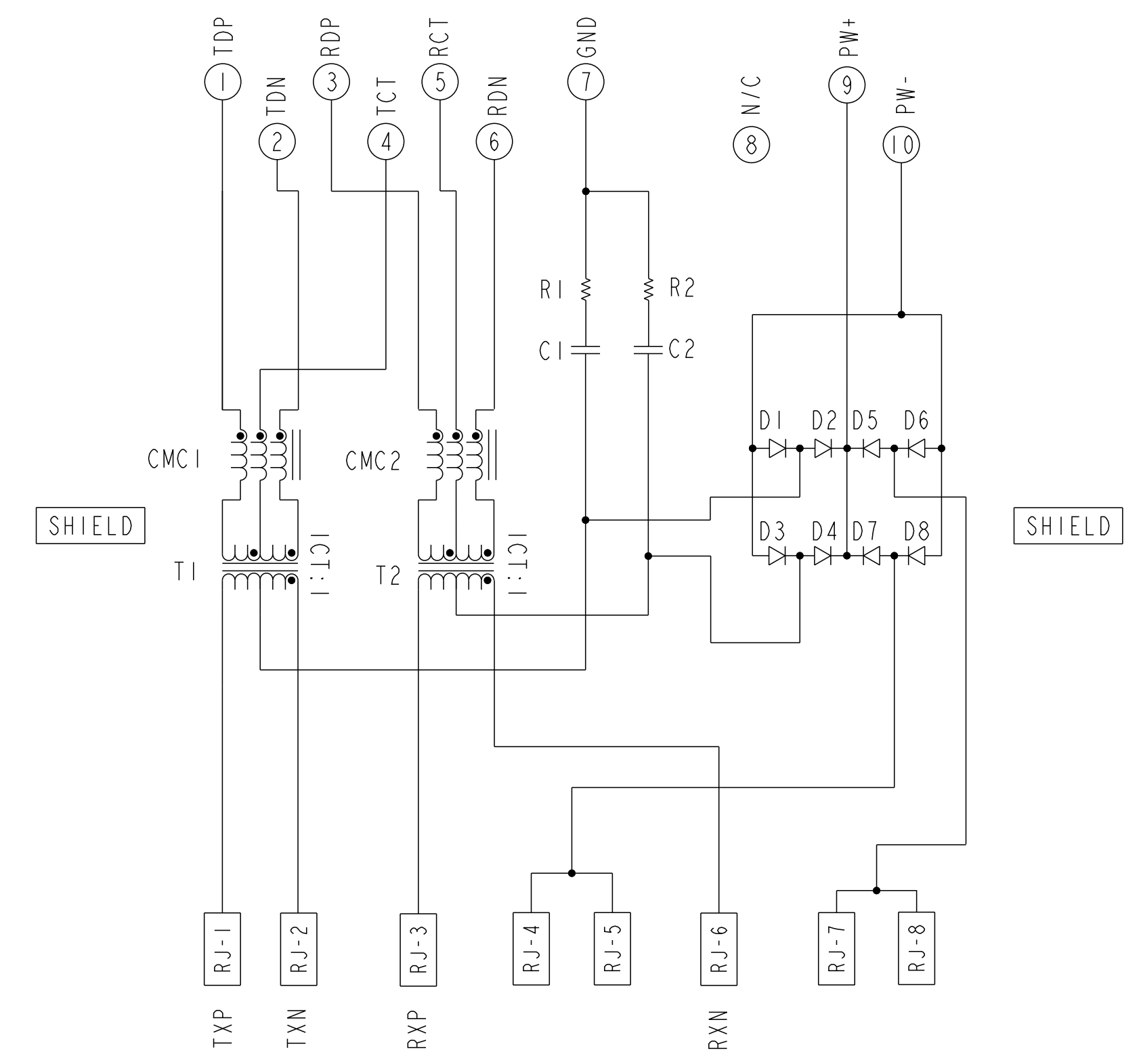

C1-C2=1000 pF, 2kV CAPACITORS

R1-R2=75 OHMS, RESISTORS

D1-D8 = RECTIFIER DIODE
 -FORWARD VOLTAGE, $V_f = 1.2V$ MAX @ $I_f = 0.5A$
 -FORWARD CURRENT, $I_f = 0.5A$ MAX
 -REVERSE VOLTAGE, $V_r = 80V$ MAX

THIS DRAWING IS A CONTROLLED DOCUMENT.		OWN ROY LIU 06 JUN 2013	 DONGGUAN CHINA
DIMENSIONS: mm		CHK TOWER YU / FRANK LIU 06 JUN 2013	
TOLERANCES UNLESS OTHERWISE SPECIFIED: 0 PLC ± 0.25 1 PLC ± 0.25 2 PLC ± 0.25 3 PLC ± 0.25 4 PLC \pm ANGLES \pm APPLICATION SPEC \pm		APP'D TONY YUAN 06 JUN 2013	
PRODUCT SPEC 108-104004		MODEL NAME MAGJACK SINGLE PoE	DESC 1X1 4D26LET 10/100 POE TAB DOWN W/ LED
		SIZE A1	RESTRICTED TO -
		CAGE CODE C=2250057	
		SCALE 4:1	SHEET 2 OF 3
		CUSTOMER DRAWING	REV 4

C_2250057					STOCK DISPOSITION			
REVISION HISTORY					A: CONTINUE AS IS B: REWORK C: SCRAP			
					D: USE OLD FIRST E: PARTS TO CONFORM F: OTHER			
DATE	REV	CHANGES	REASON	APPROVAL	INVENTORY (A,B,C,D,E,F)	WORK IN PROCESS (A,B,C,F)	SUPPLIER ORDERS (A,E,F)	OPEN CUST ORDERS (A,E,F)
06JUN2013	1	-	INITIAL RELEASE	TONY YUAN	-	-	-	-
06AUG2013	2	SHEET, C4: CHANGE DIMENSION FROM 3.68 TO 3.18	PER MARKET REQUIREMENT	TONY YUAN	-	-	-	-
29NOV2013	3	NOTE4: CHANGE THE OPERATING TEMPERATURE FROM "0°C—+70°C" TO "-40°C—+85°C"	PER MARKET REQUIREMENT	TONY YUAN	-	-	-	-
14JAN2015	4	EC-1411035 COMPANY LOGO CHANGE	MARKET REQUIREMENT	TONY YUAN	-	-	-	-

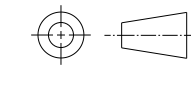
THIS DRAWING IS A CONTROLLED DOCUMENT.		DWN ROY LIU 06 JUN2013	 trp CONNECTOR <small>a bel group</small>	DONGGUAN CHINA	
DIMENSIONS: mm		CHK TOWER YU/ FRANK LIU 06 JUN2013		MODEL NAME MAGJACK SINGLE PoE	DESC IXI 4D26LET 10/100 POE TAB DOWN W/ LED
 0 PLC ±0.25 1 PLC ±0.25 2 PLC ±0.25 3 PLC ± 4 PLC ± ANGLES APPLICATION SPEC		APVD TONY YUAN 06 JUN2013			
PRODUCT SPEC 108-104004		SIZE CAGE CODE DRAWING NO A1 C=2250057		SCALE 4:1 SHEET 3 OF 3 REV 4	