

THE INFORMATION CONTAINED HEREIN IS CONSIDERED "PROPRIETARY" TO BEL FUSE INC. AND SHALL NOT BE COPIED, REPRODUCED OR DISCLOSED WITHOUT THE WRITTEN APPROVAL OF BEL FUSE INC.

RoHS
2002/95/EC



LED 2 & 4 POLARITY			LED 1 & 3 POLARITY		
PIN 11	PIN 12	COLOR	PIN 13	PIN 14	COLOR
-	+	YELLOW	-	+	YELLOW
+	-	GREEN	+	-	GREEN

PRELIMINARY

SCHEMATIC

RJ45

ELECTRICAL CHARACTERISTICS @ 25°C

URNS RATIO

TP1	1CT : 1CT ±2%
TP2	1CT : 1CT ±2%
TP3	1CT : 1CT ±2%
TP4	1CT : 1CT ±2%

QCL @ 100kHz/100mVRMS (0°C-70°C)

8mA DC BIAS 350µH MIN.

INS. LOSS

0.1MHz TO 1MHz	-1.1 dB MAX
1MHz TO 65MHz	-0.5 dB MAX
65MHz TO 100MHz	-0.8 dB MAX
100MHz TO 125MHz	-1.2 dB MAX

RET. LOSS (MIN)

0.5MHz-40MHz	-18 dB
40MHz-100MHz	-12+20LOG(f/80MHz) dB

CM TO CM REJ

100kHz - 100MHz -30 dB MIN

CM TO DM REJ

100kHz - 100MHz -35 dB MIN

HIPOT (Isolation Voltage):

1500 Vrms

100% OF PRODUCTION TESTED TO COMPLY WITH IEEE 802.3 ISOLATION REQUIREMENTS

LEDS 1, 2, 3 AND 4

VF (FORWARD VOLTAGE)	IF=20mA GREEN 2.2V TYP.
	IF=20mA YELLOW 2.1V TYP.
λD (DOMINANT WAVELENGTH)	IF=20mA GREEN 565nm TYP.
	IF=20mA YELLOW 590nm TYP.

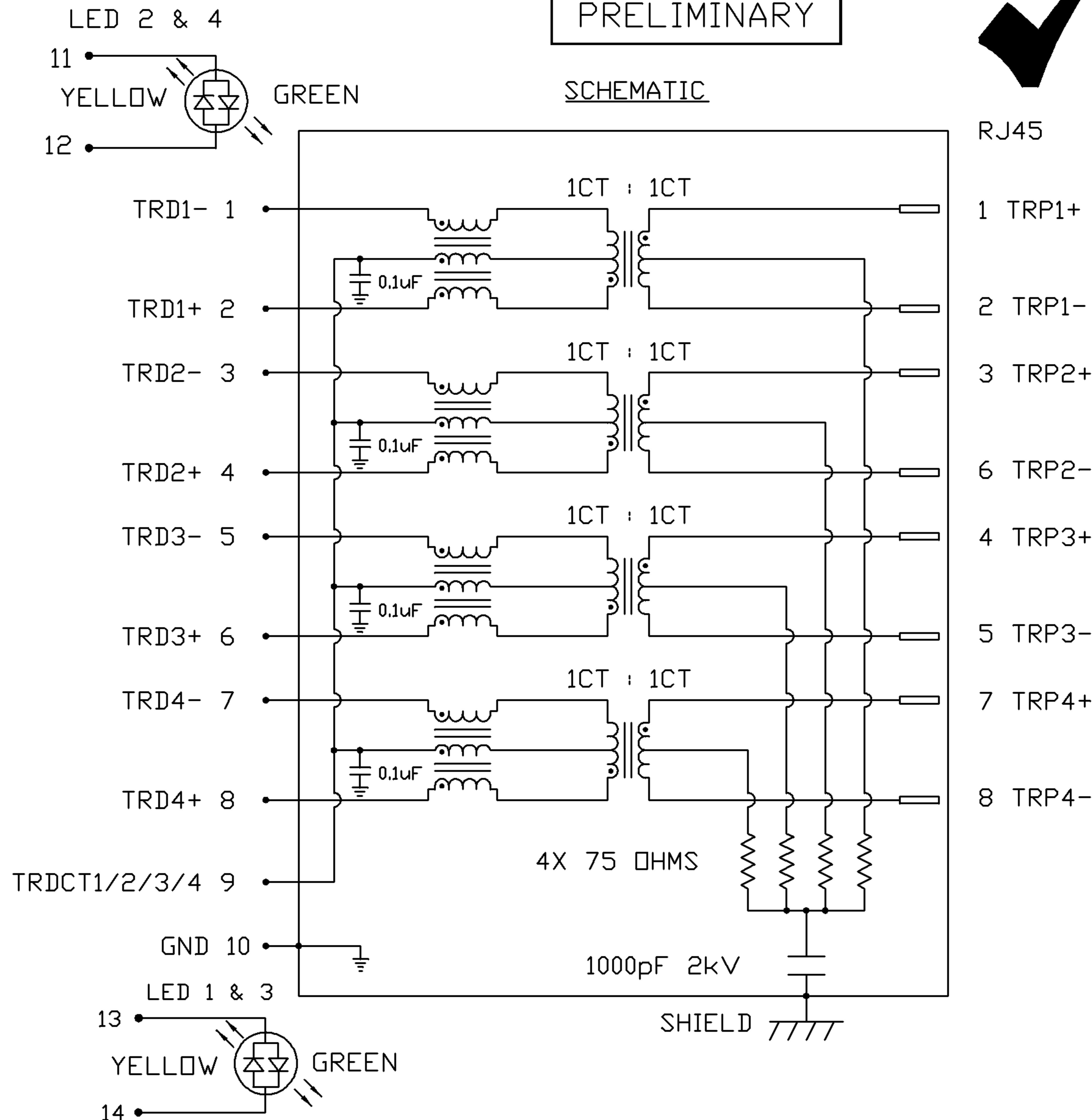

ORIGINATED BY	DATE
CHOW WANGCHUNG	11-27-08
DRAWN BY	DATE
LEE WEIDE	11-27-08

TITLE
2X1 gigabit MagJack® WITH UPPER AND LOWER LED (8 Cores)

PART NO. / DRAWING NO.
0879-2C1C-54
FILE NAME
0879-2C1C-54_PA.DWG

STANDARD DIM. TOL. IN INCH
.X
.XX
.XXX

[] METRIC DIM. AS REFERENCE
UNIT : INCH [mm]
SCALE : N/A
REV. : PA
SIZE : A4
PAGE : 2



THE INFORMATION CONTAINED HEREIN IS CONSIDERED "PROPRIETARY" TO BEL FUSE INC. AND SHALL NOT BE COPIED, REPRODUCED OR DISCLOSED WITHOUT THE WRITTEN APPROVAL OF BEL FUSE INC.

PRELIMINARY

RoHS
2002/95/EC

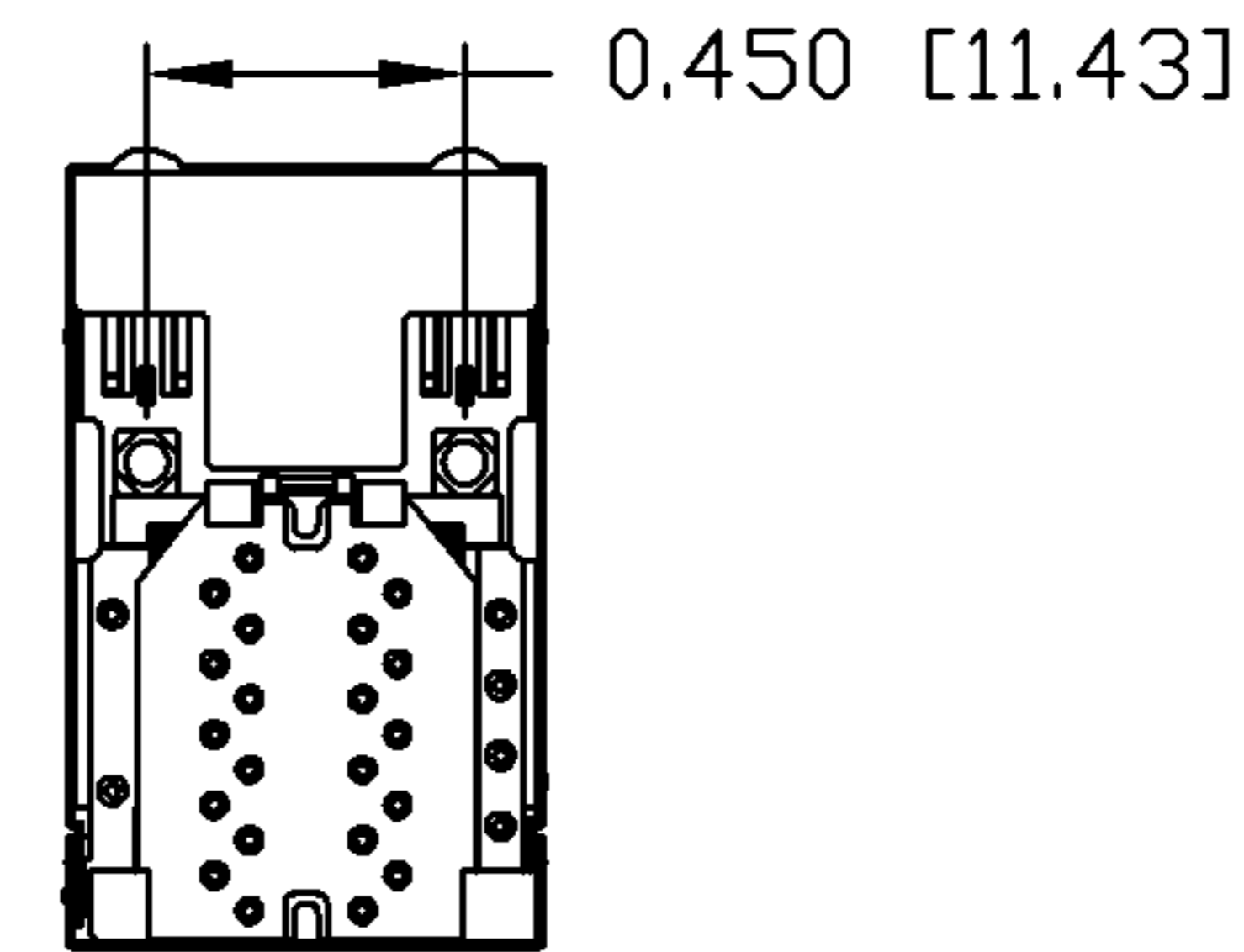
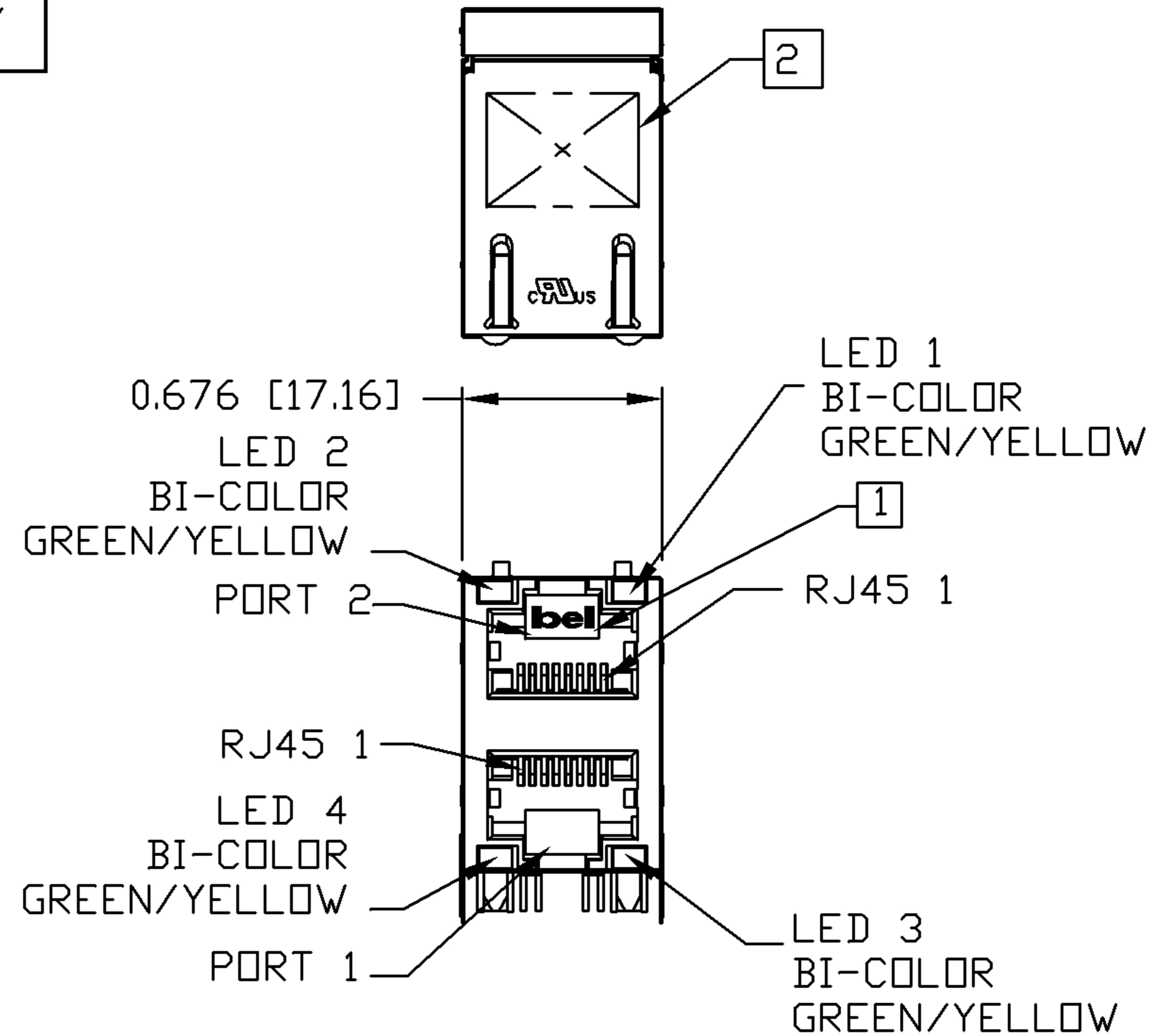
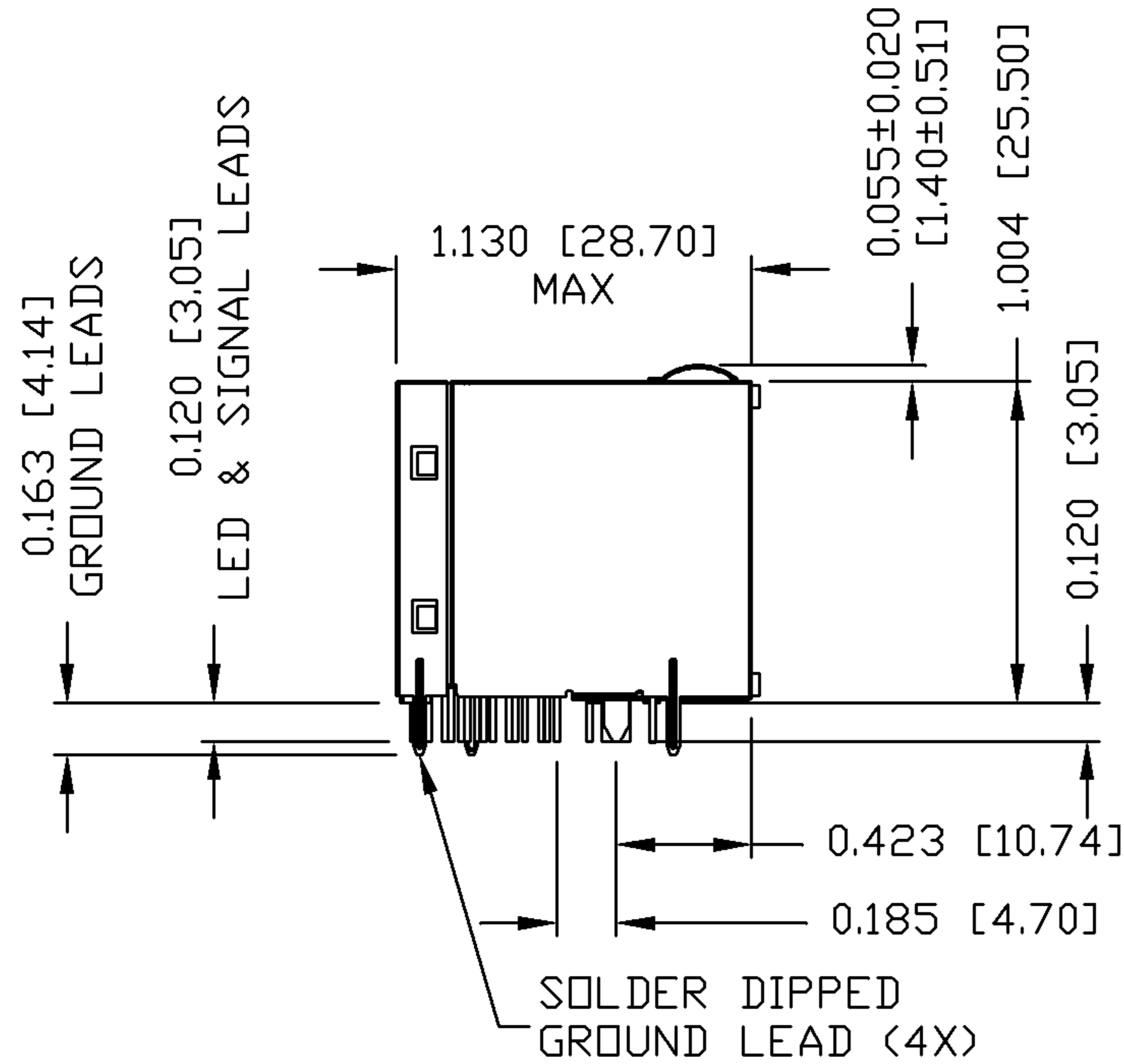

NOTES:

PLASTIC HOUSING: THERMOPLASTIC PBT
 FLAMMABILITY RATING UL 94V-0
 CONTACT PLATING: 50 MICRO-INCH HARD GOLD PLATING
 OUTPUT PINS: TIN-COATED COPPER WIRE, DIA 0.018 INCH.
 METAL SHIELD: NICKEL PLATED ON COPPER ALLOY.
 (ALL GROUND LEADS ARE SOLDER DIPPED)

- 1. JACK CAVITY CONFORMS TO FCC RULES AND REGULATIONS, PART 68 SUBPART F.
 - 2. MARK PART WITH MFG LOGO, MFG NAME, PART NUMBER, AND DATE CODE.
 - 3. RoHS COMPLIANCE, PER EU DIRECTIVE 2002/95/EC.
- c usUL RECOGNIZED - FILE #E196366 AND E169987.

ORIGINATED BY LIU QIN	DATE 11-27-08	TITLE 2X1 gigabit MagJack® WITH UPPER AND LOWER LED (8 Cores)	PART NO. / DRAWING NO. 0879-2C1C-54	STANDARD DIM. TOL. IN INCH	[] METRIC DIM. AS REFERENCE	 COMPONENTS FOR A CONNECTED PLANET	
DRAWN BY XIAN JIAXIN	DATE 11-27-08		FILE NAME 0879-2C1C-54_PA.DWG	.X	UNIT : INCH [mm]		REV. : PA
				.XX	SCALE : N/A		SIZE : A4
				.XXX	±0.010	PAGE : 3	

THE INFORMATION CONTAINED HEREIN IS CONSIDERED "PROPRIETARY" TO BEL FUSE INC. AND SHALL NOT BE COPIED, REPRODUCED OR DISCLOSED WITHOUT THE WRITTEN APPROVAL OF BEL FUSE INC.

PRELIMINARY

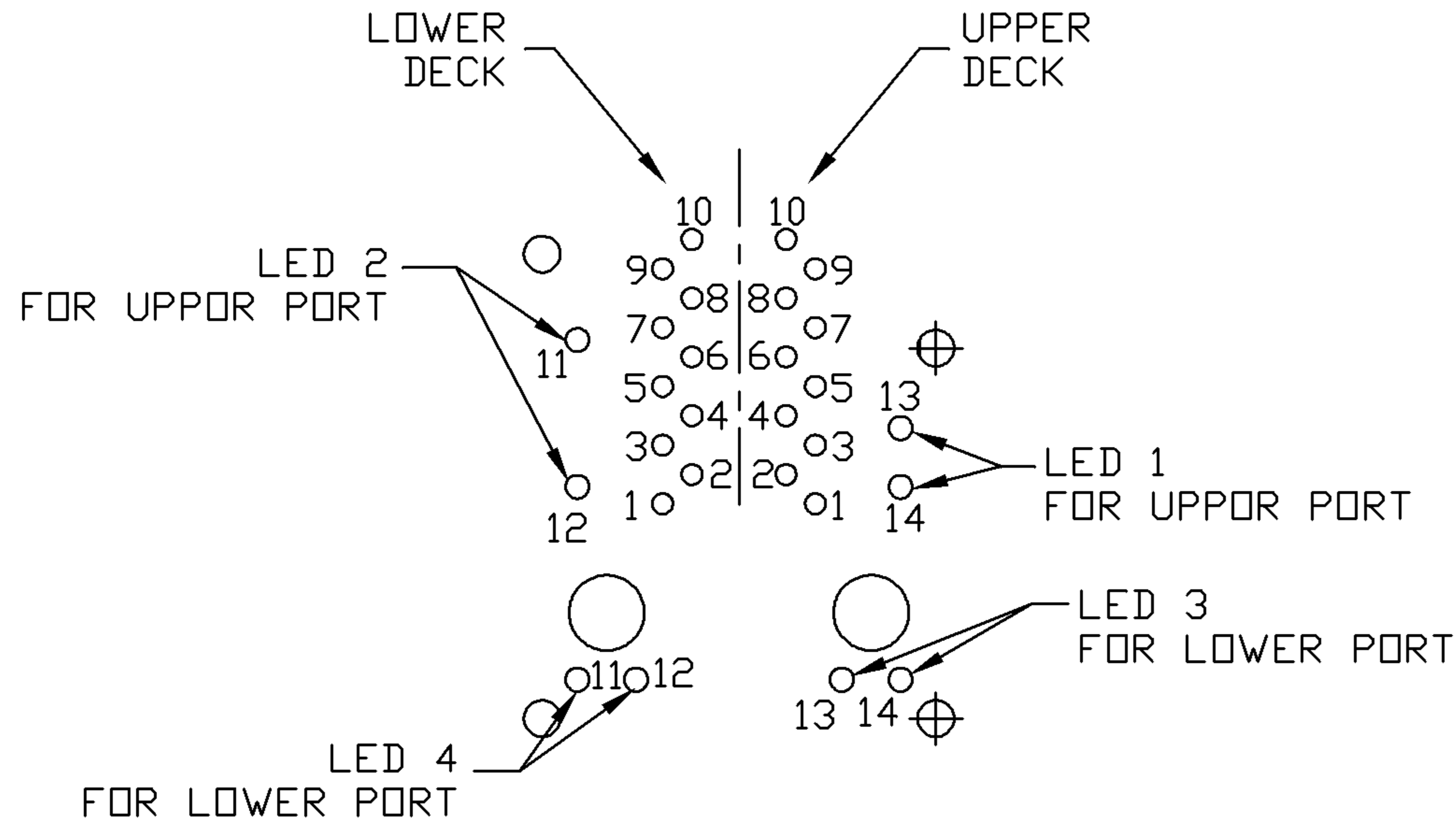

PIN-OUT INFORMATION
(COMPONENT SIDE VIEW)

10	GND		
9	TRCT1/2/3/4		
8	TRD 4+		
7	TRD 4-		
6	TRD 3+		
5	TRD 3-		
4	TRD 2+	14	GREEN (-) YELLOW (+)
3	TRD 2-	13	GREEN (+) YELLOW (-)
2	TRD 1+	12	GREEN (-) YELLOW (+)
1	TRD 1-	11	GREEN (+) YELLOW (-)

PORT ASSIGNMENT
(COMPONENT SIDE VIEW)

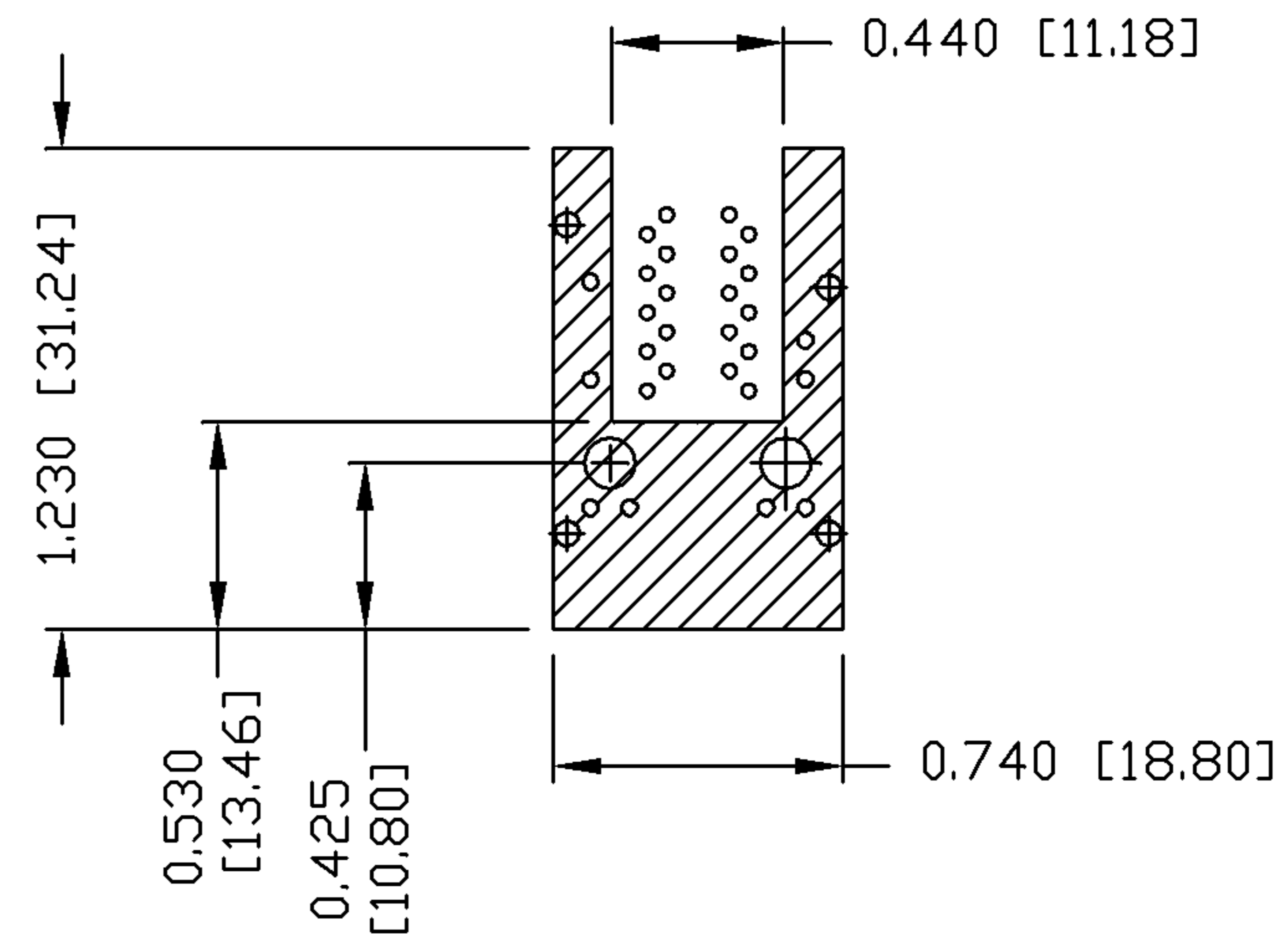
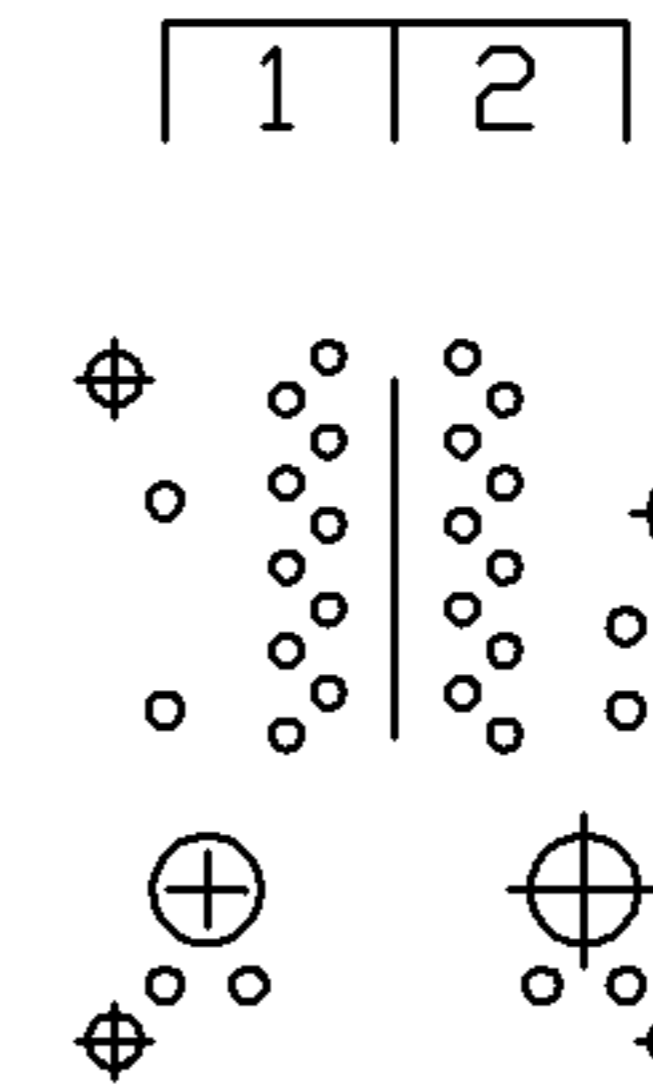

THE SHADED AREA ON THE CUSTOMER BOARD ARE RECOMMENDED TO BE CLEAR OFF ANY VIA HOLE OR COMPONENT PAD.

ORIGINATED BY LIU QIN	DATE 11-27-08	TITLE 2X1 gigabit MagJack® WITH UPPER AND LOWER LED (8 Cores)	PART NO. / DRAWING NO. 0879-2C1C-54	STANDARD DIM. TOL. IN INCH	[] METRIC DIM. AS REFERENCE	 COMPONENTS FOR A CONNECTED PLANET	
DRAWN BY XIAN JIAXIN	DATE 11-27-08		FILE NAME 0879-2C1C-54_PA.DWG	.X	UNIT : INCH [mm]		REV. : PA
				.XX	SCALE : N/A		SIZE : A4
			.XXX	±0.004	PAGE : 4		

THE INFORMATION CONTAINED HEREIN IS CONSIDERED "PROPRIETARY" TO BEL FUSE INC. AND SHALL NOT BE COPIED, REPRODUCED OR DISCLOSED WITHOUT THE WRITTEN APPROVAL OF BEL FUSE INC.

PRELIMINARY

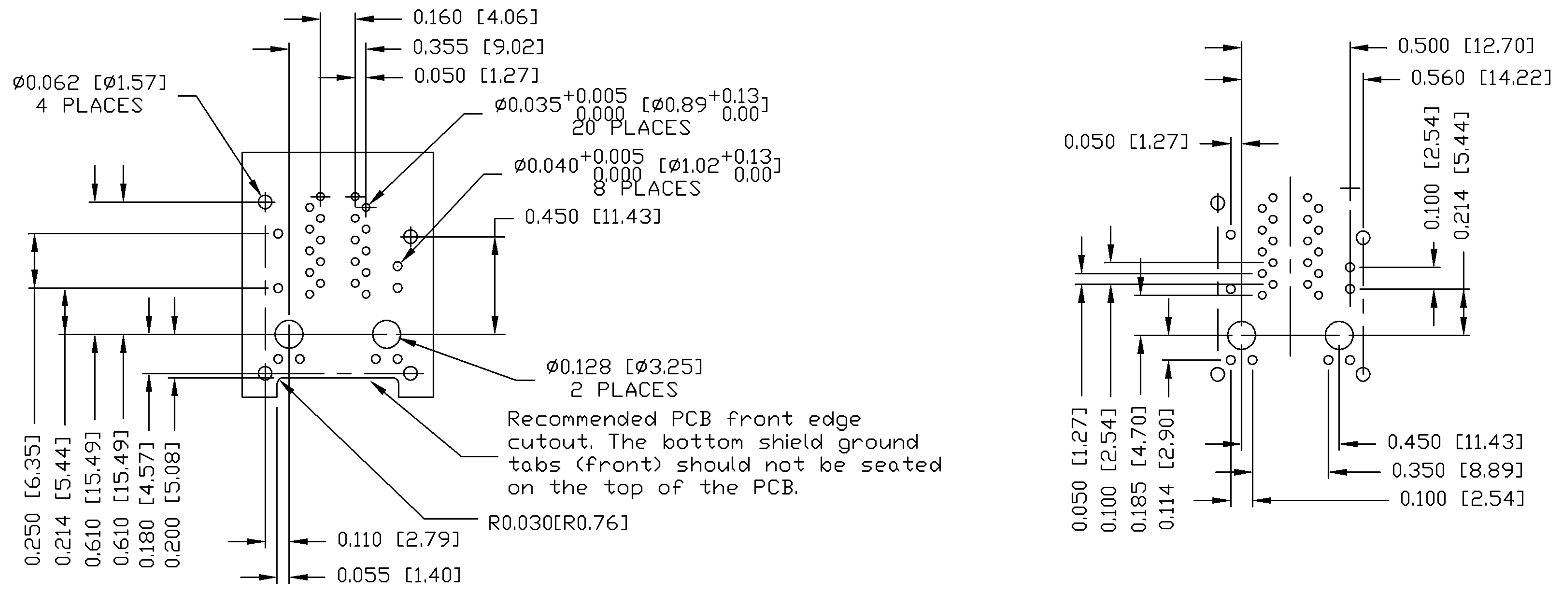

SUGGESTED FOOTPRINT
(COMPONENT SIDE VIEW)

Recommended PCB front edge cutout. The bottom shield ground tabs (front) should not be seated on the top of the PCB.

ORIGINATED BY LIU QIN	DATE 11-27-08	TITLE 2X1 gigabit MagJack® WITH UPPER AND LOWER LED (8 Cores)	PART NO. / DRAWING NO. 0879-2C1C-54	STANDARD DIM. TOL. IN INCH	[] METRIC DIM. AS REFERENCE	 COMPONENTS FOR A CONNECTED PLANET	
DRAWN BY XIAN JIAXIN	DATE 11-27-08	FILE NAME 0879-2C1C-54_PA.DWG	.X	/	UNIT : INCH [mm]		REV. : PA
			.XX	/	SCALE : N/A		SIZE : A4
			.XXX	±0.004			PAGE : 5

THE INFORMATION CONTAINED HEREIN IS CONSIDERED "PROPRIETARY" TO BEL FUSE INC. AND SHALL NOT BE COPIED, REPRODUCED OR DISCLOSED WITHOUT THE WRITTEN APPROVAL OF BEL FUSE INC.

SUGGESTED PANEL OPENING

PRELIMINARY

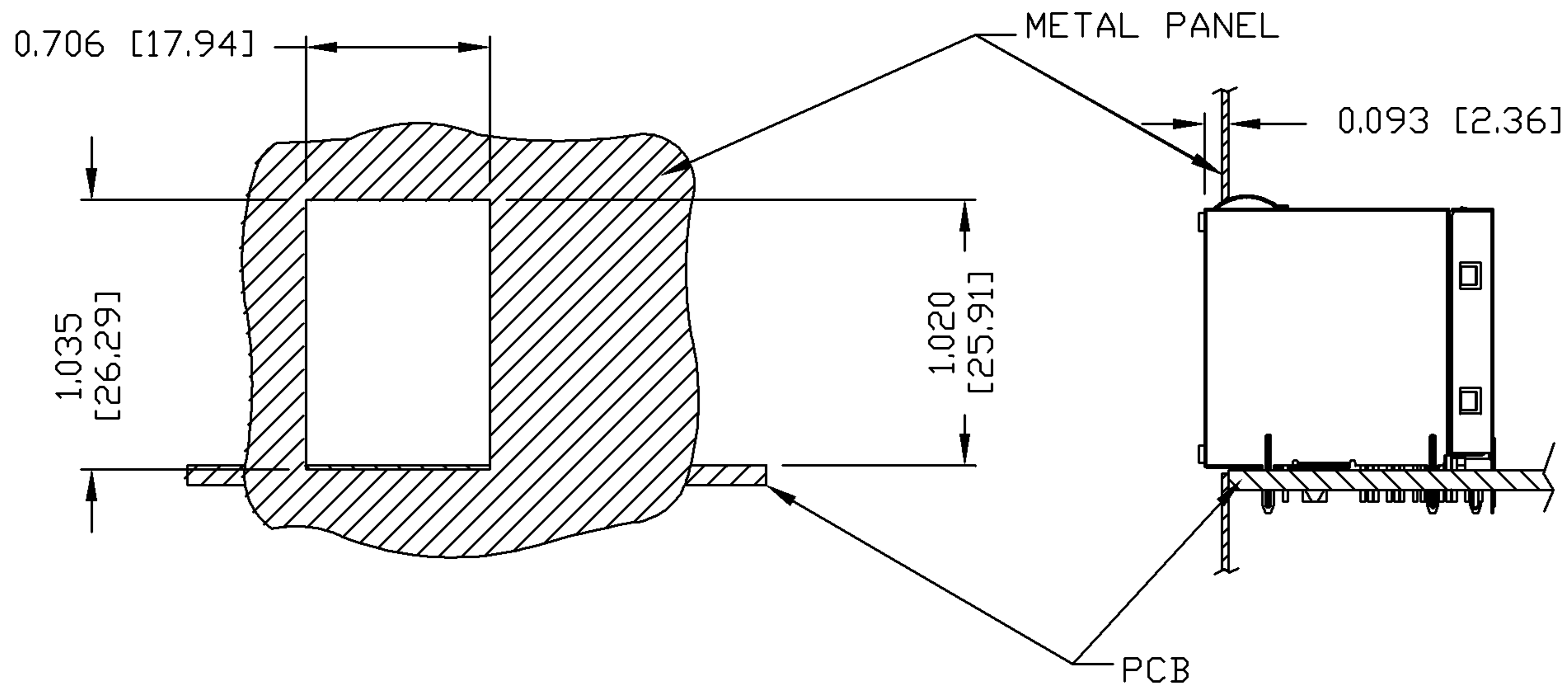

NOTE:

THE DISTANCE OF PANEL INSIDE SURFACE RELATIVE TO FRONT SURFACE OF PART IS ONLY A SUGGESTION. IN CASE THIS DISTANCE IS DIFFERENT, THE REQUIRED PANEL OPENING DIMENSIONS CHANGE ACCORDINGLY.

PACKING INFORMATION

PACKING TRAY : 0200-9999-P8 (TOP)
0200-9999-P9 (BOTTOM)

PACKING QUANTITY : 40 PCS FINISHED GOODS PER TRAY
7 TRAYS (280 PCS FINISHED GOODS) PER CARTON BOX

NOTE : CARDBOARDS ARE PLACED BETWEEN LAYERS OF PACKING TRAY INSIDE CARTON BOX (INCLUDE THE UPPERMOST AND LOWERMOST TRAY)

ORIGINATED BY	DATE	TITLE 2X1 glgabit MagJack® WITH UPPER AND LOWER LED (8 Cores)	PART NO. / DRAWING NO.	STANDARD DIM.	[] METRIC DIM. AS REFERENCE	
LIU QIN	11-27-08		0879-2C1C-54	TOL. IN INCH	UNIT : INCH [mm]	REV. : PA
DRAWN BY	DATE		FILE NAME	.X	SCALE : N/A	SIZE : A4
XIAN JIAXIN	11-27-08		0879-2C1C-54_PA.DWG	.XX	⊕ - - - ⊕	PAGE : 6
				.XXX		

