

THE INFORMATION CONTAINED HEREIN IS CONSIDERED "PROPRIETARY" TO BEL FUSE INC. AND SHALL NOT BE COPIED, REPRODUCED OR DISCLOSED WITHOUT THE WRITTEN APPROVAL OF BEL FUSE INC.

RoHS

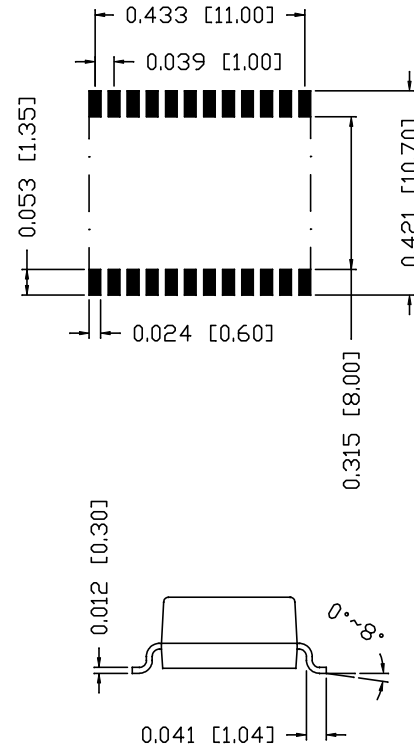

SUGGESTED PCB PAD LAYOUT

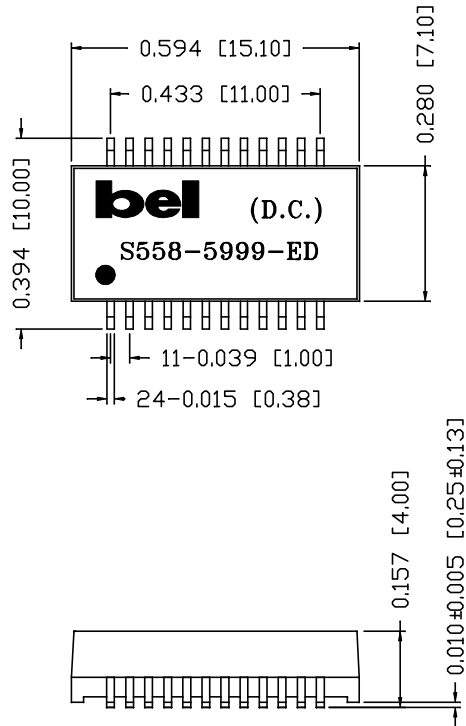

NOTES:

1. STANDARD MARKING REFER TO DOC. HAND-WORK-04.
2. PACKAGE CODE: "CQS001".

ORIGINATED BY
SHEA
DATE 2024-04-23
DRAWN BY
CHEN ZHIJUN
DATE 2024-04-23

TITLE
1000Base-T
Transformer module

PART NO. / DRAWING NO.
S558-5999-ED
FILE NAME
S558-5999-ED.DWG

STANDARD DIM. TOL. IN INCH	[] METRIC DIM. AS REF.
.X	UNIT : INCH [mm]
.XX	SCALE : N/A
.XXX	SIZE : A4

REV. : A PAGE : 1/2



THE INFORMATION CONTAINED HEREIN IS CONSIDERED "PROPRIETARY" TO BEL FUSE INC. AND SHALL NOT BE COPIED, REPRODUCED OR DISCLOSED WITHOUT THE WRITTEN APPROVAL OF BEL FUSE INC.

RoHS



ELECTRICAL CHARACTERISTICS @ 25°C

SCHEMATIC

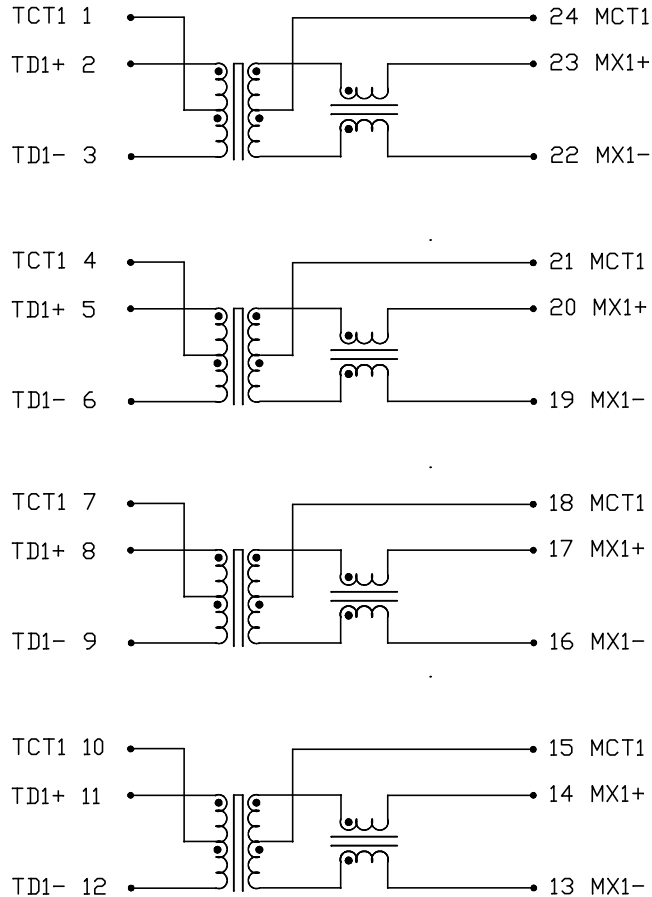

URNS RATIO:

PIN(22-23-24) : (1-2-3)
 PIN(21-20-19) : (4-5-6)
 PIN(16-17-18) : (7-8-9)
 PIN(13-14-15) : (10-11-12)

1CT:1CT±5%
 1CT:1CT±5%
 1CT:1CT±5%
 1CT:1CT±5%

POLARITY:

PER DOT CONVENTION

□CL (0°C~70°C):

PIN(22-24)=(21-19)=(16-18)=(15-13)

@100kHz, 100mV WITH 8mA DC BIAS 350 H/MIN.

INSERTION LOSS:

1.0dB MAX. @ 1 TO 100MHZ

RETURN LOSS:

18.0dB MIN. @ 1 TO 30MHZ
 14.4dB MIN. @ 40MHZ
 13.1dB MIN. @ 50MHZ
 12.0dB MIN. @ 60 TO 80MHZ
 10.0dB MIN. @ 100MHZ

DCMR:

40.0dB MIN. @ 30MHZ
 35.0dB MIN. @ 60MHZ
 30.0dB MIN. @ 100MHZ

CROSS TALK:

45.0dB MIN. @ 30MHZ
 40.0dB MIN. @ 60MHZ
 35.0dB MIN. @ 100MHZ

HIPOT:

LEAKAGE CURRENT LESS THAN
 1mA AT 1500VAC

ORIGINATED BY
 SHEA
 DATE 2024-04-23
 DRAWN BY
 CHEN ZHIJUN
 DATE 2024-04-23

TITLE
 1000Base-T
 Transformer module

PART NO. / DRAWING NO.
 S558-5999-ED
 FILE NAME
 S558-5999-ED.DWG

STANDARD DIM. TOL. IN INCH	[] METRIC DIM. AS REF.
.X	UNIT : INCH [mm]
.XX	SCALE : N/A
.XXX	SIZE : A4

REV. : A PAGE : 2/2

