

THE INFORMATION CONTAINED HEREIN IS CONSIDERED "PROPRIETARY" TO BEL FUSE INC, AND SHALL NOT BE COPIED, REPRODUCED OR DISCLOSED WITHOUT THE WRITTEN APPROVAL OF BEL FUSE INC.

LED1 POLARITY			LED2 POLARITY		
PIN 17	PIN 18	COLOR	PIN 19	PIN 20	COLOR
+	-	YELLOW	+	-	YELLOW
-	+	GREEN	-	+	GREEN

RoHS



ELECTRICAL CHARACTERISTICS @ 25°C

URNS RATIO

TP1	1CT : 1CT
TP2	1CT : 1CT
TP3	1CT : 1CT
TP4	1CT : 1CT

INS. LOSS (MAX)

1MHz TO 20MHz	-0.8 dB
50MHz	-1.0 dB
200MHz	-1.2 dB
400MHz	-2.0 dB
500MHz	-3.0 dB

RET. LOSS (MIN)

1MHz - 40MHz	-16 dB
40MHz - 400 MHz	-16+10LOG (F/40) dB
400MHz - 500 MHz	-6+30LOG (F/400) dB

CM TO CM REJ

1MHz - 100MHz	-30 dB MIN
---------------	------------

HIPOT (Isolation Voltage): 2250 VDC

100% OF PRODUCTION TESTED TO COMPLY WITH IEEE 802.3 ISOLATION REQUIREMENTS.

LED1 AND LED2

VF (FORWARD VOLTAGE)	IF=20mA	GREEN	2.2V TYP.
		YELLOW	2.1V TYP.
λD (DOMINANT WAVELENGTH)	IF=20mA	GREEN	570nm TYP.
		YELLOW	590nm TYP.

BALANCED DC LINE CURRENT 600mA MAX CONTINUOUS

1.2A MAX. FOR 200 MILLISECONDS

OPERATING TEMPERATURE: -40°C TO 85°C

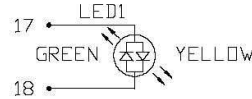

SCHEMATIC

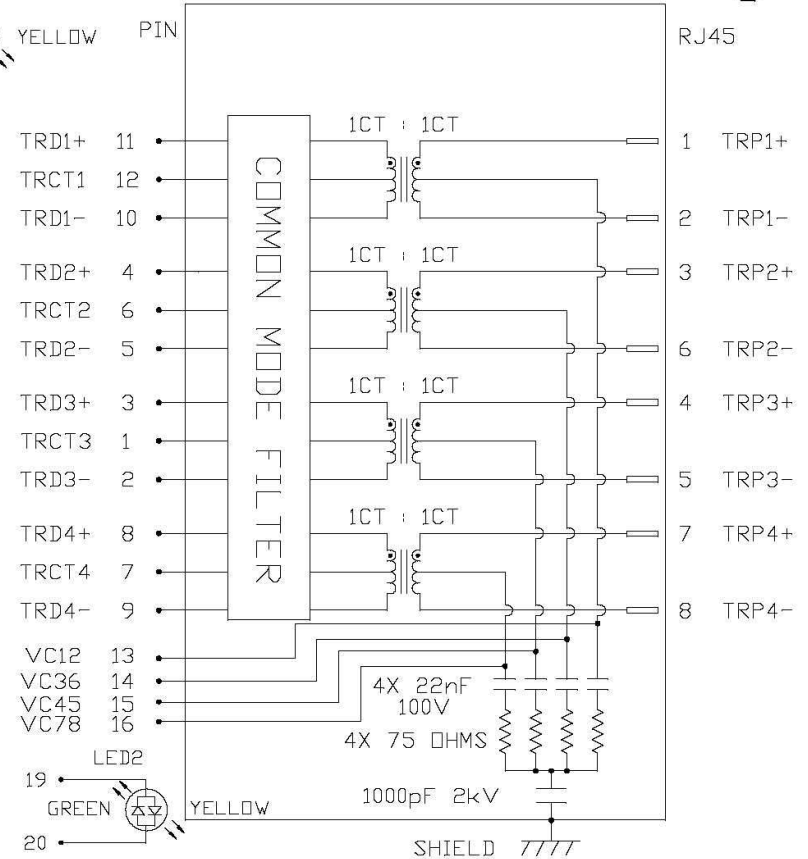

REV. : PB PAGE : 2

ORIGINATED BY
CHOW WANCHUNG
DATE 2020-08-07

DRAWN BY
XIE YIMING
DATE 2020-08-07

TITLE
10 gigabit MagJack®
Vertical, 4PPoE
PATENTED

PART NO. / DRAWING NO.
G55-122N-155

FILE NAME
G55-122N-155_PB.DWG

STANDARD DIM. TOL. IN INCH	[] METRIC DIM. AS REF.
.X	UNIT : INCH [mm]
.XX	SCALE : N/A
.XXX	SIZE : A4



THE INFORMATION CONTAINED HEREIN IS CONSIDERED "PROPRIETARY" TO BEL FUSE INC, AND SHALL NOT BE COPIED, REPRODUCED OR DISCLOSED WITHOUT THE WRITTEN APPROVAL OF BEL FUSE INC.

RoHS

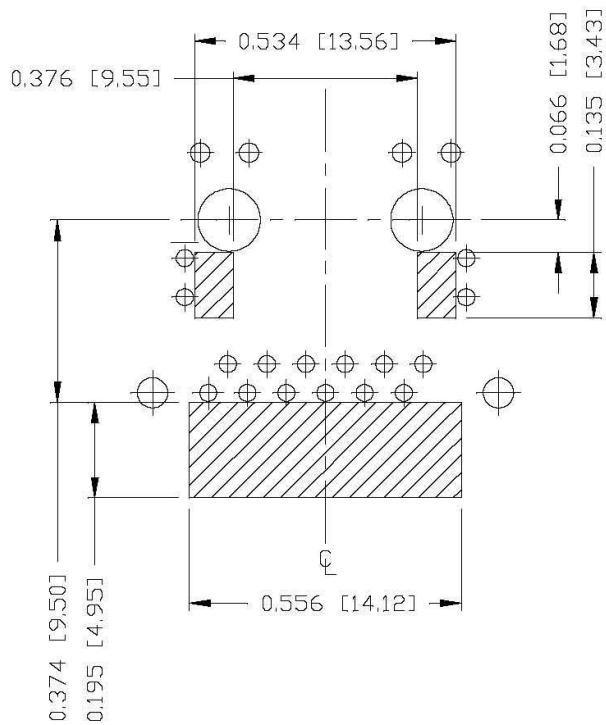

NOTES
THE SHADED AREA ON THE CUSTOMER BOARD ARE RECOMMENDED TO BE CLEAR OFF ANY VIA HOLE OR COMPONENT PAD.

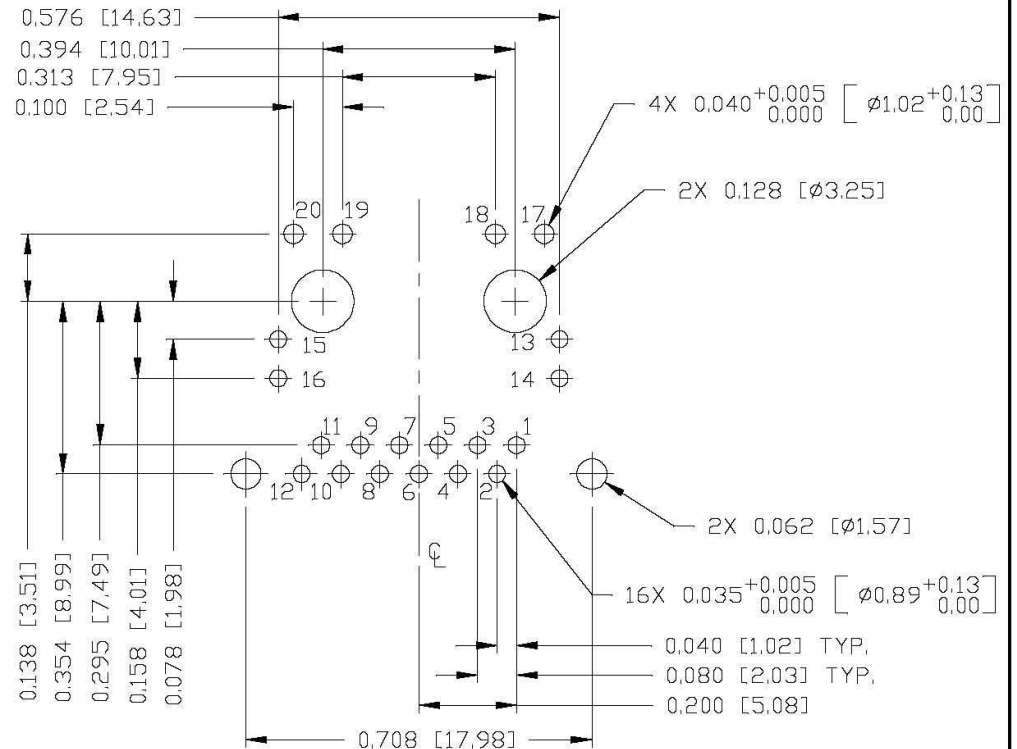

RECOMMENDED PCB FOOTPRINT
COMPONENT SIDE VIEW

ORIGINATED BY
LI QUANKUN
DATE 2020-08-07

DRAWN BY
OLIVER ZHANG
DATE 2020-08-07

TITLE
10 gigabit MagJack®
Vertical, 4PPoE
PATENTED

PART NO. / DRAWING NO.
G55-122N-155

FILE NAME
G55-122N-155_PB.DWG

STANDARD DIM.
TOL. IN INCH [] METRIC DIM.
AS REF.

.X		UNIT : INCH [mm]
.XX		SCALE : N/A
.XXX	±0.004	SIZE : A4

REV. : PB PAGE : 4



THE INFORMATION CONTAINED HEREIN IS CONSIDERED "PROPRIETARY" TO BEL FUSE INC, AND SHALL NOT BE COPIED, REPRODUCED OR DISCLOSED WITHOUT THE WRITTEN APPROVAL OF BEL FUSE INC.



SUGGESTED PANEL OPENING

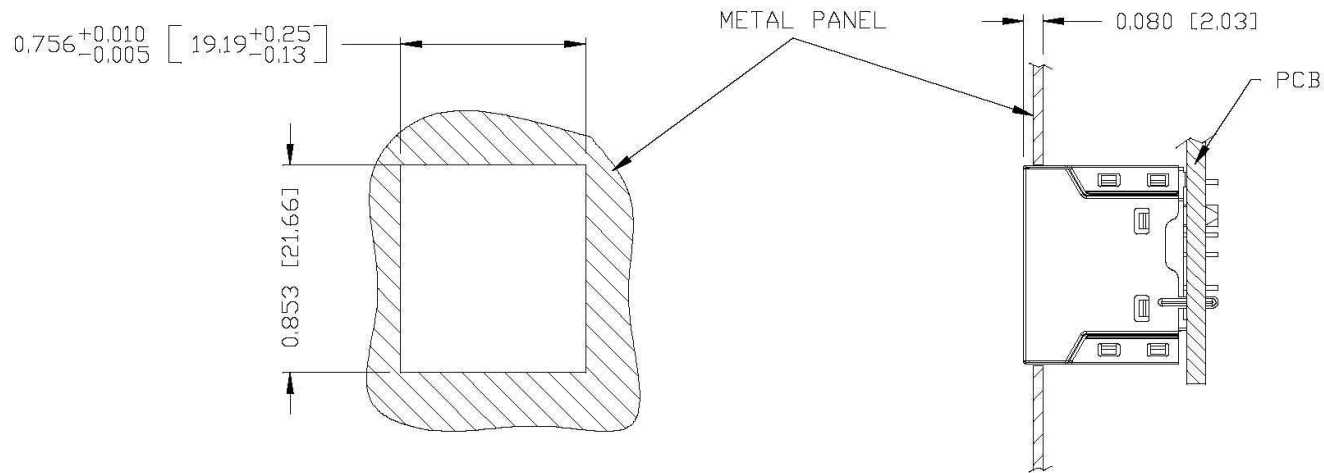

NOTES:

THE DISTANCE OF PANEL INSIDE SURFACE RELATIVE TO FRONT SURFACE OF PART IS ONLY A SUGGESTION. IN CASE THIS DISTANCE IS DIFFERENT, THE REQUIRED PANEL OPENING DIMENSIONS CHANGE ACCORDINGLY.

PACKING INFORMATION

PACKING TRAY : 0200M9999-T1(TOP)

0200M9999-T0(BOTTOM)

PACKING QUANTITY : 50 PCS FINISHED GOODS PER TRAY

9 TRAYS (450 PCS FINISHED GOODS) PER CARTON BOX

NOTER: CARDBOARDS ARE PLACED BETWEEN LAYERS OF PACKIING TRAY INSIDE CARTON BOX (INCLUDE THE UPPERMOST AND LOWERMOST TRAY)

REV. : PB PAGE : 5

ORIGINATED BY LI QUANKUN DATE 2020-08-07	TITLE 10 glgabit MagJack® Vertical, 4PPoE PATENTED	PART NO. / DRAWING NO. G55-122N-155	STANDARD DIM. TOL. IN INCH	[] METRIC DIM. AS REF.	
		FILE NAME G55-122N-155_PB.DWG	.X .XX .XXX	UNIT : INCH [mm] SCALE : N/A SIZE : A4	
		.XXX ±0.005	