

RED IS ORIGINAL

DISK #	DWG SIZE	DATA CONTAINED IN THIS DOCUMENT IS PROPRIETARY TO TROMPETER ELECTRONICS, INC. AND SHALL NOT BE DISCLOSED, COPIED OR USED FOR PROCUREMENT OR MANUFACTURE WITHOUT EXPRESS WRITTEN PERMISSION.	REV	EO	DESCRIPTION	310-0069	SH 1
K 3	C		E	10055	SH1: PICTORIALLY REVISED SEALING SLEEVE; GENERAL UPDATE SH2: SEE ECO	DWN APPROVED	DATE
						DWG	12/1/92

DASH NO	MODEL NO	CENTER CONTACT/INTMD CONTACT TYPE
-1	PLR3455ACP	SOCKET/PIN
-2	PLR3455ACS	PIN/SOCKET

CABLE GROUP NO	CABLES ACCOMMODATED	A HEX	B MAX	C DIM	ASSEMBLE PER				
-201	M17/176-00002	.255	1.60	1.43	TA1-170				
-202	TWC-78-1, TROMPETER								
-203	TWC-124-1A, TROMPETER								
-204	10802, RAYCHEM								
-205	TWAC-78-1F2, TROMPETER								
-206	782600130, RAYCHEM								
-208	202-3927, MICRODOT								
-209	202-3942, MICRODOT								
-212	2S24E0114, RAYCHEM								
-217	6CB75TM24H, GRUMMAN								
-218	EPD22188B, RAYCHEM								
-219	2S26D1114, RAYCHEM								
-220	6CB75SR1, GRUMMAN								
-221	10814, RAYCHEM								
-222	10813, RAYCHEM								
-223	HMS2-1149, HUGHES								
-303	1059B, RAYCHEM					.344	1.88	1.49	TAI-186

INCH	MM
.005	0.13
.03	0.76
.045	1.14
.255	6.48
.450	11.43
1.10	27.94
1.25	31.75
1.43	36.32

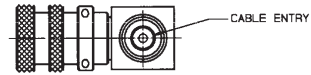
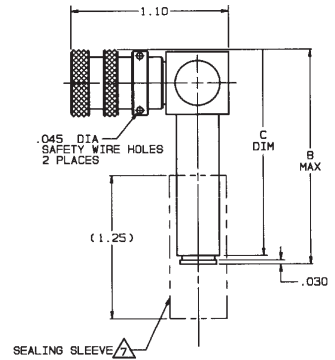
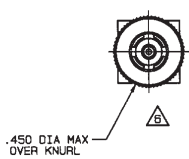

-1 -201 SHOWN

- ⚠ STRAIN RELIEF SUPPLIED LOOSE WITH -303 ONLY
- ⚠ SEALING SLEEVE & CRIMP BUSHING SUPPLIED LOOSE WITH EACH CONNECTOR; EXCEPT SEALING SLEEVE NOT USED ON -205, -208 & -223
- ⚠ BOTTOM PORTION NOT SHOWN FOR CLARITY

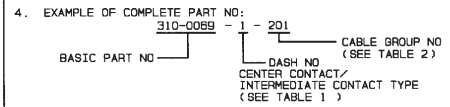
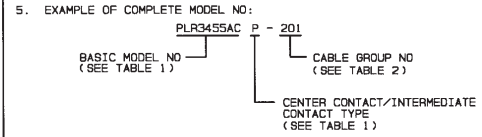

- 3. CONCENTRIC TWINAX 4 PIECE ASSY, RIGHT ANGLE FULL CRIMP CABLE PLUG, SOCKET CENTER CONTACT AND PIN INTERMEDIATE CONTACT OR PIN CENTER CONTACT AND SOCKET INTERMEDIATE CONTACT
- 2. FINISH: TFS-1U (500 HR SALT SPRAY), NICKEL
- 1. ALL DIM ARE IN INCHES

QTY	DESCRIPTION	PART NUMBER	ITEM
TOL UNLESS SPECIFIED XX ± .03 .XXX ± .005 XXXX ANG LES	TROMPETER RF connectivity	PLR3455AC/P/S	
DWN	DKG	12/2/92	
CHK	DKG	12/2/92	
ENGR	DKG	12/2/92	
APPR	DKG	12/2/92	
MATERIAL	CODE IDENT	DRAWING NO.	REV
	14949	310-0069	E
NEXT ASSY	SCALE 2/1	DATE 11/4/88	SHEET 1 OF 2