

RED IS ORIGINAL

DASH NO	MODEL NO	CENTER CONTACT/ INTMD CONTACT TYPE
-1	PLR3455ACP	SOCKET/PIN
-2	PLR3455ACS	PIN/SOCKET

CABLE GROUP NO	CABLES ACCOMMODATED	A HEX	B MAX	C DIM	ASSEMBLE PER
-201	M17/176-00002				
-202	TWC-76-1, TROMPETER				
-203	TWC-124-1A, TROMPETER				
-204	10802, RAYCHEM				
-205	TWAC-76-1F2, TROMPETER				
-206	782600130, RAYCHEM				
-208	202-3927, MICRODOT	.255	1.60	1.43	TA1-170
-209	202-3942, MICRODOT				
-212	2S24E0114, RAYCHEM				
-217	6CB75TM24H, BRUMMAN				
-218	EPD22188B, RAYCHEM				
-219	2S26D1114, RAYCHEM				
-220	6CB75SRL1, BRUMMAN				
-221	10814, RAYCHEM				
-222	10813, RAYCHEM				
-223	HMS2-1149, HUGHES				
-303	1059B, RAYCHEM	.344	1.88	1.49	TA1-186

INCH	MM
.005	0.13
.03	0.76
.045	1.14
.255	6.48
.450	11.43
1.10	27.94
1.25	31.75
1.43	36.32



- ⚠ STRAIN RELIEF SUPPLIED LOOSE WITH -303 ONLY
- ⚠ SEALING SLEEVE & CRIMP BUSHING SUPPLIED LOOSE WITH EACH CONNECTOR; EXCEPT SEALING SLEEVE NOT USED ON -205, -208 & -223
- ⚠ BOTTOM PORTION NOT SHOWN FOR CLARITY
- 5. EXAMPLE OF COMPLETE MODEL NO:

PLR3455AC P - 201
 BASIC MODEL NO CABLE GROUP NO
 (SEE TABLE 1) (SEE TABLE 2)
 CENTER CONTACT/INTERMEDIATE CONTACT TYPE
 (SEE TABLE 1)
- 4. EXAMPLE OF COMPLETE PART NO:

310-0069 - 1 - 201
 BASIC PART NO DASH NO CABLE GROUP NO
 CENTER CONTACT/INTERMEDIATE CONTACT TYPE
 (SEE TABLE 1)
- 3. CONCENTRIC TWINAX 4 PIECE ASSY, RIGHT ANGLE FULL CRIMP CABLE PLUG, SOCKET CENTER CONTACT AND PIN INTERMEDIATE CONTACT OR PIN CENTER CONTACT AND SOCKET INTERMEDIATE CONTACT
- 2. FINISH: TFS-1U (500 HR SALT SPRAY), NICKEL
- 1. ALL DIM ARE IN INCHES

DISK #	DWG SIZE	DATA CONTAINED IN THIS DOCUMENT IS PROPRIETARY TO TROMPETER ELECTRONICS, INC. AND SHALL NOT BE DISCLOSED, COPIED OR USED FOR PROCUREMENT OR MANUFACTURE WITHOUT EXPRESS WRITTEN PERMISSION.
K 3	C	

REV	EO	DESCRIPTION	310-0069	SH 1
E	10055	SH1: PICTORIALLY REVISED SEALING SLEEVE; GENERAL UPDATE SH2: SEE ECO	DWN	APPROVED
			DWG	DATE
				12/1/92

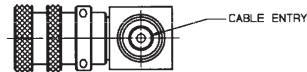
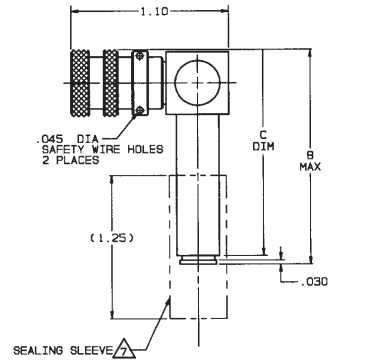

-1 -201 SHOWN

QTY	DESCRIPTION	PART NUMBER	ITEM	
TOL UNLESS SPECIFIED XX ± .03 .XXX ± .005 XXXXX	TROMPETER RF connectivity	PLR3455ACP/S		
DWN	DWG	12/2/92		
CHK	12/1/92			
ENGR				
		MATERIAL	CODE IDENT	
			14949	
		DRAWING NO.	310-0069	
		REV	E	
NEXT ASSY	APPR	SCALE 2/1	DATE 11/4/88	SHEET 1 OF 2