

DASH NO	CABLES ACCOMMODATED	ASSEMBLE PER
-23	275-3930, MICRODOT	TAI-127
-24	202-3934, MICRODOT	TAI-125
-24A	9530A5117, RAYCHEM	TAI-127
-27	202-3927, MICRODOT <sup>5</sup> 73-1317911-1, SYLVANIA	TAI-125
-29	TWC-124-1A TWC-7B-1	TAI-125
-30	8441, BELDEN <sup>4</sup> 761A, W.E.CO.	
-32	TRC-50-1	TAI-127
-33	TRC-75-1	
-43	250-4044/250-4045 293-3930 MICRODOT	TAI-174
-45	10602, RAYCHEM	TAI-125
-47	MIL/176-00002 <sup>5</sup>	
-49	TWAC-7B-1F2 <sup>5</sup>	
-56	GC875GC1, GRUMMAN	TAI-174
-57	GC875GB1, GRUMMAN	
-58	GC875TM24H, GRUMMAN	TAI-125
-9	TWC-124-2 <sup>4</sup>	
-55	TWCP-124-3 <sup>4</sup>	

DATA CONTAINED IN THIS DOCUMENT IS PROPRIETARY TO TROMPETER ELECTRONICS INC. AND SHALL NOT BE DISCLOSED, COPIED OR USED FOR PROCUREMENT OR MANUFACTURE WITHOUT EXPRESS WRITTEN PERMISSION OF TROMPETER ELECTRONICS INC.

REVISIONS		315-0027	SH 1
REV	DESCRIPTION	DATE	APPROVED
N	REVISED PER ECO 14786	11-5-02	AM

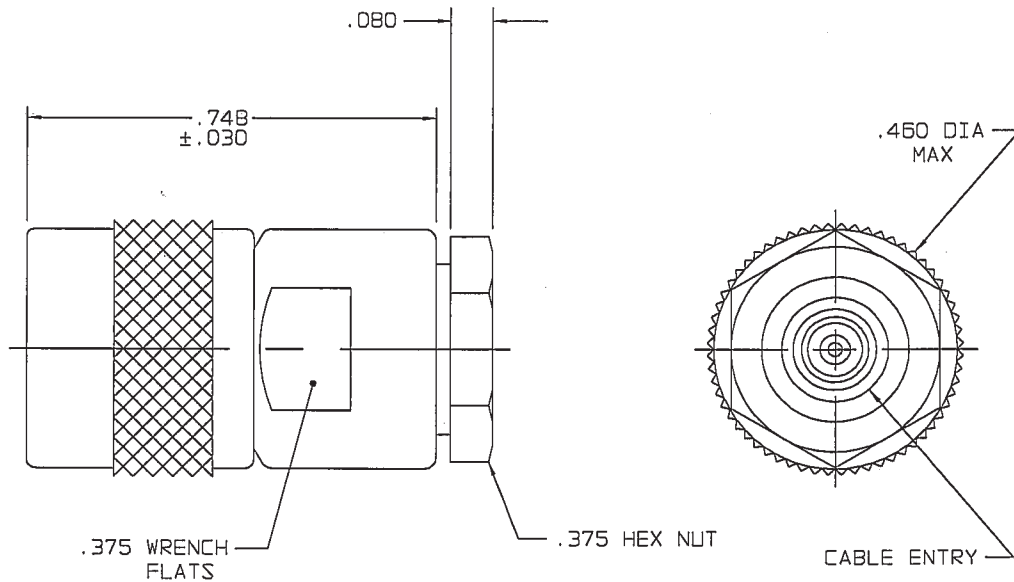

-29 SHOWN

**RED INDICATES ORIGINAL**

- <sup>5</sup> .187 LG JACKET SLITS MAY BE REQUIRED FOR EASE OF ASSY
- <sup>4</sup> NOT WRENCH CRIMP
- 3. CONCENTRIC TWINAX/TRIAX SUBMINIATURE 4-LUG TRS PLUG
- 2. FINISH: TFS-1A (NICKEL)
- 1. ALL DIM ARE IN INCHES

INTERPRET DRAWING PER MIL-STD-100 DIMENSIONS ARE IN INCHES AND INCLUDE FINISH THICKNESS UNLESS OTHERWISE SPECIFIED		TOL: UNLESS SPECIFIED .XX .XXX ± .005 .XXXX		 a cinch connectivity solutions brand	
DRAWN AAH	DATE 11-4-02	MATERIAL:	TITLE: PL155FL		
CHECKED JLM	DATE 11-4-02	FINISH:	SIZE CAGE CODE <b>A 14949</b>	DRAWING NO. 315-0027	REV. N
QUALITY [Signature]	DATE 11-5-02				
HANDLE LWN	DATE 11/5/02	DO NOT SCALE DWG			
APPROVED [Signature]	DATE 11/4/02	NEXT ASSY			
CAD FILE NO. 315-0027N					