

DASH NO	CABLES ACCOMMODATED	ASSEMBLE PER
-23	275-3930, MICRODOT	TAI-127
-24	202-3934, MICRODOT	TAI-125
-24A	9530A5117, RAYCHEM	TAI-127
-27	202-3927, MICRODOT <sup>5</sup> 73-1317911-1, SYLVANIA	TAI-125
-29	TWC-124-1A TWC-78-1	TAI-125
-30	8441, BELDEN <sup>4</sup> 761A, W.E.CO.	
-32	TRC-50-1	TAI-127
-33	TRC-75-1	
-43	250-4044/250-4045 293-3930 MICRODOT	TAI-174
-45	10602, RAYCHEM	TAI-125
-47	M17/176-00002 <sup>5</sup>	
-49	TWAC-78-1F2 <sup>5</sup>	
-56	GC875GC1, GRUMMAN	TAI-174
-57	GC875GB1, GRUMMAN	
-58	GC875TM24H, GRUMMAN	TAI-125
-55	TWCP-124-3	

DATA CONTAINED IN THIS DOCUMENT IS PROPRIETARY TO TROMPETER ELECTRONICS INC. AND SHALL NOT BE DISCLOSED, COPIED OR USED FOR PROCUREMENT OR MANUFACTURE WITHOUT EXPRESS WRITTEN PERMISSION OF TROMPETER ELECTRONICS INC.

REVISIONS		310-0036	SH 1
REV	DESCRIPTION	DATE	APPROVED
V	REVISED PER ECO 15485	2/14/04	WJ

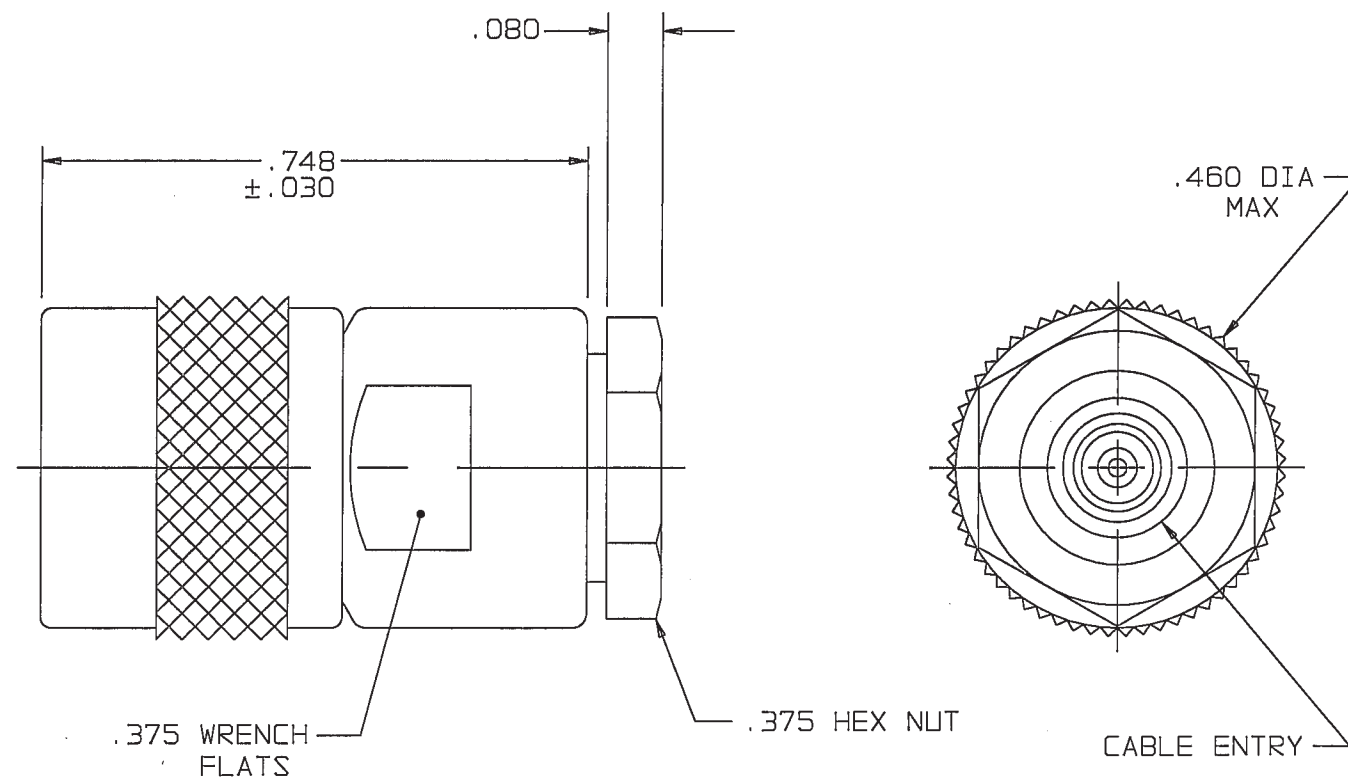

-29 SHOWN

**RED INDICATES ORIGINAL**

<sup>5</sup> .187 LG JACKET SLITS MAY BE REQUIRED FOR EASE OF ASSY

<sup>4</sup> NOT WRENCH CRIMP

3. CONCENTRIC TWINAX/TRIAX SUBMINIATURE 3-LUG TRS PLUG
2. FINISH: TFS-1A (NICKEL)
1. ALL DIM ARE IN INCHES

INTERPRET DRAWING PER MIL-STD-100 DIMENSIONS ARE IN INCHES AND INCLUDE FINISH THICKNESS UNLESS OTHERWISE SPECIFIED		TOL: UNLESS SPECIFIED .XX ±.01 .XXX ±.005 .XXXX ±.0010 ANGLES ± 0° 30'		TROMPETER RF connectivity a cinch connectivity solutions brand	
310-0026	AAH	DATE	6-10-04	TITLE: PL155	
305-0374	AAH	DATE	6-10-04	SIZE CAGE CODE DRAWING NO. REV.	
3-0040	AAH	DATE	6/14/04	B 14949	310-0036 V
3-0029	AAH	DATE	6/14/04	SCALE	4/1
205-0029	AAH	DATE	6/14/04	DATE:	6/20/75
1-0451	AAH	DATE	6/14/04	SHEET	1C
NEXT ASSY	CAD FILE NO.	310-0036V		DO NOT SCALE DWG	