

REV	ECO	DATE
1	ECO-19-0033	7/31/2019
1A	ECO-19-0038	9/9/2019

MODEL NUMBER

147-0701-251

BOARD EDGE

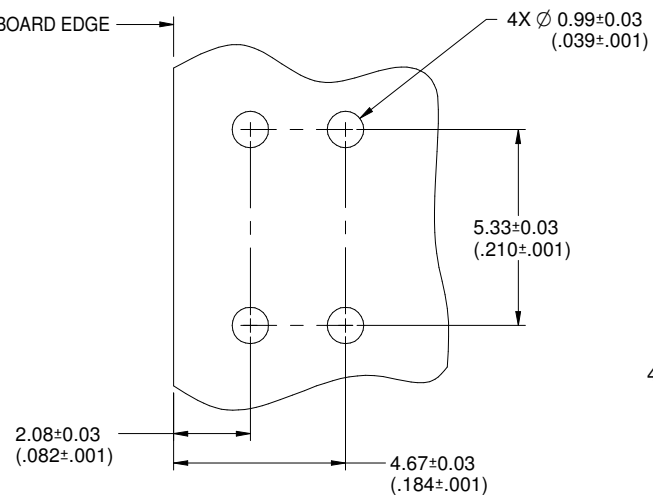

RECOMMENDED MOUNTING HOLE DIMENSIONS

SPECIFICATION:

ELECTRICAL:

- IMPEDANCE: 50 OHMS
- FREQUENCY RANGE: 0-50 GHz
- VSWR: 1.5 MAX
- INSERTION LOSS: 0.05 √F dB MAX (F IN GHz)
- WORKING VOLTAGE: 150 VRMS MAX AT SEA LEVEL
- DIELECTRIC WITHSTANDING VOLTAGE: 500VRMS MIN AT SEA LEVEL
- INSULATION RESISTANCE: 5000 MEGOHM MIN
- CONTACT RESISTANCE:
 - CENTER CONTACT - INITIAL 4 MILLIOHM MAX, AFTER ENVIRONMENTAL NOT APPLICABLE
 - OUTER CONDUCTOR - INITIAL 2.5 MILLIOHM MAX, AFTER ENVIRONMENTAL NOT APPLICABLE
- RF LEAKAGE: -90dB TYPICAL AT 2.5GHz

MECHANICAL:

- COUPLING TORQUE RECOMMENDED: 0.8 Nm TO 1.1 Nm
- COUPLING TEST TORQUE: 1.65 Nm
- DURABILITY: 500 CYCLES MIN

ENVIRONMENTAL:

- OPERATING TEMPERATURE: -40 TO 85°C
- THERMAL SHOCK: IEC 61169-1, SUBCLAUSE 9.4.4
- CORROSION: IEC 61169-1, SUBCLAUSE 9.4.6
- SHOCK: IEC 61169-1, SUBCLAUSE 9.3.14
- VIBRATION: IEC 61169-1, SUBCLAUSE 9.3.3
- MOISTURE RESISTANCE: IEC 61169-1, SUBCLAUSE 9.4.3

MATERIAL AND FINISH:

- BODY: GOLD PLATED BRASS
- CENTER CONTACT: GOLD PLATED BERYLLIUM COPPER
- INSULATOR: PTFE (TEFLON)

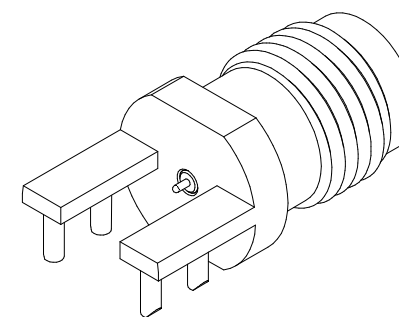
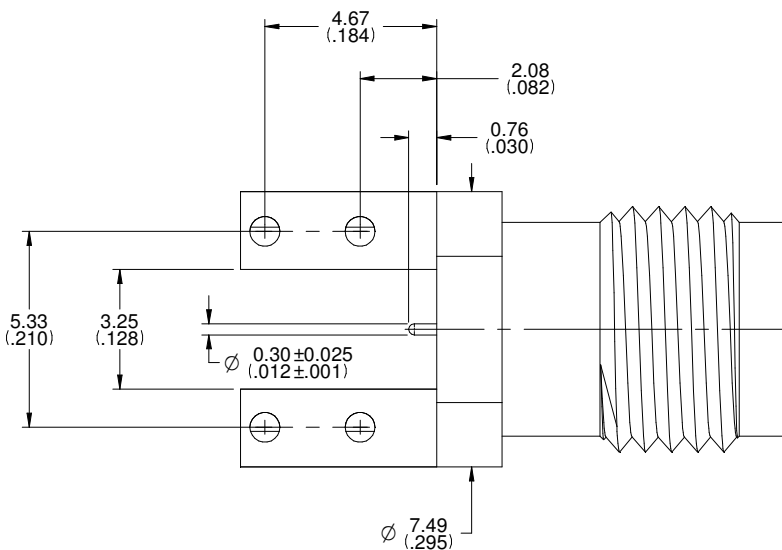
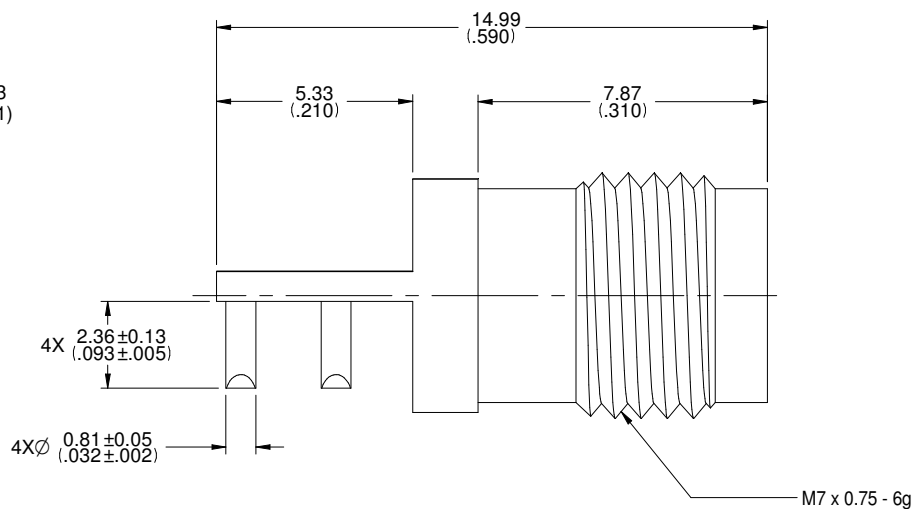

	SEE NOTE	Model No. 147-0701-251	
	SEE NOTE	RoHS2 201185 EU	
SEE NOTE X ±0.2 XX ±0.1 XXX ±0.07 ANGLES 12 DEG	Date: 7/31/19 Scale: C DO NOT SCALE DRAWING	Design: R.SHEN	Sheet 1 of 1