

PART NUMBER	ITEM ① BODY	ITEM ② CONTACT	ITEM ③ INSULATOR	ITEM ④ COUPLING NUT	ITEM ⑤ COUPLING SPRING
134-1010-005	BRASS GOLD PL .00003 MIN OVER NICKEL PL .00005 MIN OVER COPPER	BERYLLIUM COPPER GOLD PL .00005 MIN OVER NICKEL PL .00005 MIN OVER COPPER	TEFLON	BRASS GOLD PL .00001 MIN OVER NICKEL PL .00005 MIN OVER COPPER PL .00005 MIN	BERYLLIUM COPPER UNPLATED

REV	ECO	DATE
1	INITIAL RELEASE	23APR2023
2	EC-2311012	29NOV2023

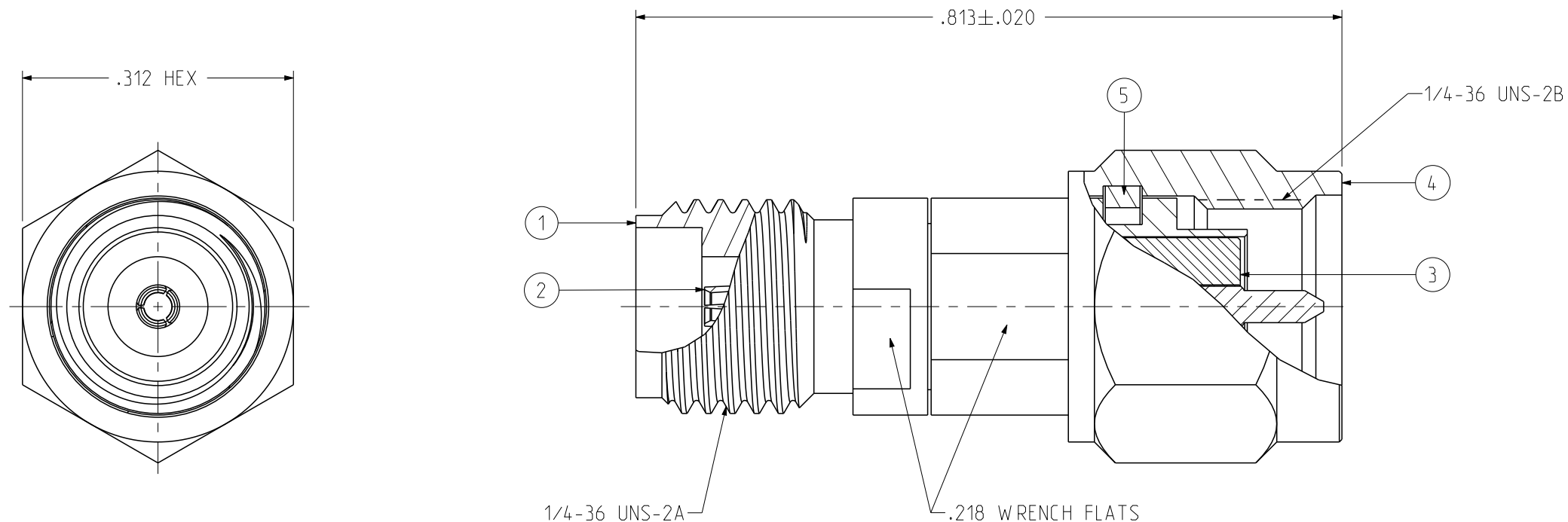

NOTES:

1. ELECTRICAL SPECIFICATIONS:

- 1.1 IMPEDANCE: 50 OHMS
- 1.2 FREQUENCY RANGE: DC-26.5 GHz
- 1.3 VSWR: 1.15 MAX.
- 1.4 WORKING VOLTAGE: 250 VRMS MAX AT SEA LEVEL
- 1.5 DIELECTRIC WITHSTANDING VOLTAGE: 750 VRMS MIN AT SEA LEVEL
- 1.6 INSULATION RESISTANCE: 5000 MEGOHM MIN
- 1.7 CONTACT RESISTANCE:
  - 1.7.1 CENTER CONTACT - INITIAL 3 MILLIOHM MAX, AFTER ENVIRONMENTAL NOT APPLICABLE
  - 1.7.2 OUTER CONDUCTOR - INITIAL 2 MILLIOHM MAX, AFTER ENVIRONMENTAL NOT APPLICABLE

2. MECHANICAL SPECIFICATIONS:

- 2.1 ENGAGEMENT/DISENGAGEMENT FORCE: 2 INCH-POUNDS MAX
- 2.2 MATING TORQUE: 7 TO 10 INCH-POUNDS MAX
- 2.3 DURABILITY: 500 CYCLES MIN

3. ENVIRONMENTAL:

- 3.1 THERMAL SHOCK: MIL-STD-202, METHOD 107, CONDITION B
- 3.2 OPERATING TEMPERATURE: -65 °C TO 165 °C
- 3.3 CORROSION: MIL-STD-202, METHOD 101, CONDITION B
- 3.4 SHOCK: MIL-STD-202, METHOD 213, CONDITION B
- 3.5 VIBRATION: MIL-STD-202, METHOD 204, CONDITION B
- 3.6 MOISTURE: MIL-STD-202, METHOD 106

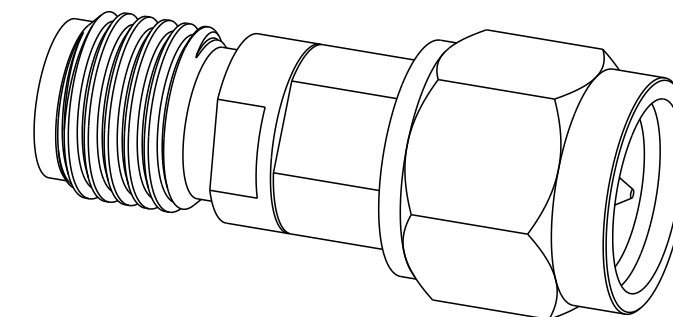

SCALE 4:1

<p>This PROPRIETARY Document is property of Cinch Connectivity Solutions. It is confidential in nature, non-transferable, and issued with the clear understanding that it is not traced or copied without permission and is returnable upon demand.</p> <p>INTERPRET DRAWING IN ACCORDANCE WITH ASME Y14.5-2018.</p>	Model No: 134-1010-005	JOHNSON	
	RoHS <input checked="" type="checkbox"/> (EU)/2015/863 COMPLIANT UNLESS OTHERWISE SPECIFIED UNITS: INCH .XX ± .01 .XXX ± .003 .XXXX ± .0010 ANGLE ± 2°	Cage Code 3RD ANGLE PROJECTION Drawn by: Roman.Yao Date: 04/23/2023	Title: ADAPTER, 2.92MM JACK TO SMA PLUG, BRASS Drawing No. 134-1010-005 Size B DO NOT SCALE DRAWING Workmanship Std/Sheet NONE 1 OF 1