

# NON-ISOLATED DC/DC CONVERTERS

4.5 Vdc -14 Vdc Input    0.75 Vdc - 5.0 Vdc/6 A Output



Jan. 25, 2013

Bel Power, Inc. , a subsidiary of Bel Fuse, Inc.

xRBA-06E2Ax Series    RoHS Compliant    Rev.D

## Features

- Non-Isolated
- High Efficiency
- High Power Density
- Fixed Frequency
- Flexible Output Voltage Sequencing
- Certificated to UL60950-1/CSA C22.2 No.60950-1, 2rd edition, am1
- Under-voltage Lockout (UVLO)
- Remote On/Off
- OCP/SCP
- Wide Input
- Wide Trim Range

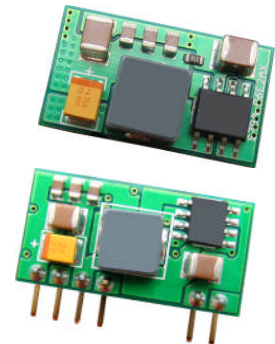

## Applications

- Networking
- Computers and peripherals
- Telecommunications

## Description

The Bel xRBA-06E2Ax modules are a series of non-isolated dc/dc converters that can deliver up to 6 A of output current with full load efficiency of 92% at 5.0 Vdc output. These modules provide precisely regulated voltage programmable via external resistor from 0.75 Vdc to 5.0 Vdc over a wide range of input voltage. These modules have a sequencing feature that enables designers to implement various types of output voltage sequencing when powering multiple voltages on a board. Their open-frame construction and small footprint enable designers to develop cost and space-efficient solutions. Standard features include remote On/Off, programmable output voltage and over current protection.

## Part Selection

Output Voltage	Input Voltage	Max. Output Current	Max. Output Power	Typical Efficiency	Model Number Surface Mount	Model Number Vertical Mount
5.0 V	7.0 V - 14 V	6 A	30.0 W	92%	SRBA-06E2Ax	VRBA-06E2Ax
0.75 V - 3.3 V <sup>1</sup>	4.5 V - 14 V	6 A	19.8 W	88%	SRBA-06E2Ax	VRBA-06E2Ax

- Notes:** 1. These modules use a buck topology, so the output voltages must be 0.5 V less than the input voltage.  
2. Use "0" to replace "x" for remote on/off active high logic and use "L" for active low logic. Change the last character "L" to "C" to indicate 0.20" pin length. Add "G" suffix at the end of the model numbers to indicate Tray Packaging.

## Part Number Explanation

$\frac{x}{1} \frac{R}{2} \frac{BA}{3} - \frac{06}{4} \frac{E}{5} \frac{2A}{6} \frac{x}{7}$

1---Change "x" to "0" indicated Horizontal mount, Change "x" to "V" indicated Vertical mount

2---RoHS 6, change "R" to "7" means RoHS 5

3---Series name

4---Series code

5---Wide input range (4.5-14V)

6---Wide trim

7---Option, "x" of the model part number to be 0-9, A-Z, which will represent the special request of customer.

# NON-ISOLATED DC/DC CONVERTERS

4.5 Vdc -14 Vdc Input    0.75 Vdc - 5.0 Vdc/6 A Output



Jan. 25, 2013

Bel Power, Inc., a subsidiary of Bel Fuse, Inc.

## Absolute Maximum Ratings

Parameter	Min	Typ	Max	Notes
Input Voltage (continuous)	-0.3 V	-	15 V	
Output Enable Terminal Voltage	-0.3 V	-	15 V	
Sequencing Voltage <sup>1</sup>	-0.3 V	-	V <sub>in</sub>	
Ambient Temperature	-40 °C	-	85 °C	
Storage Temperature	-55 °C	-	125 °C	

**Notes:** All specifications are typical at 25 °C unless otherwise stated.

1. xRBA-06E2Ax series of modules include a sequencing feature that enables users to implement various types of output voltage sequencing in their applications. This is accomplished via an additional sequencing pin. When the sequencing feature is not used, tie the SEQ pin to V<sub>in</sub>.

## Input Specifications

Parameter	Min	Typ	Max	Notes
Input Voltage				
V <sub>o, set</sub> ≤ 3.3 V	4.5 V	12 V	14 V	
V <sub>o, set</sub> = 5.0 V	7.0 V	12 V	14 V	
Input Current (full load)				
V <sub>o</sub> = 5.0 V	-	2.75 A	4.8 A	
V <sub>o</sub> = 3.3 V	-	1.85 A	4.8 A	
V <sub>o</sub> = 1.8 V	-	1.05 A	3.2 A	
V <sub>o</sub> = 0.75 V	-	0.55 A	1.8 A	
Input Current (no load)				
V <sub>o</sub> = 5.0 V	-	-	100 mA	
V <sub>o</sub> = 0.75 V	-	-	20 mA	
Remote Off Input Current	-	3 mA	5 mA	
Input Reflected Ripple Current (pk-pk)	-	120 mA	200 mA	With simulated source impedance of 1 uH, 5 Hz to 20 MHz and two 100 uF/25 V external input tantalum capacitors.
Input Reflected Ripple Current (rms)	-	60 mA	100 mA	
I <sup>2</sup> t Inrush Current Transient	-	0.002 A <sup>2</sup> s	0.02 A <sup>2</sup> s	
Turn-on Voltage Threshold				
V <sub>o, set</sub> ≤ 3.3 V	-	4.3 V	4.5 V	
V <sub>o, set</sub> = 5.0 V	-	6.0 V	6.5 V	
Turn-off Voltage Threshold				
V <sub>o, set</sub> ≤ 3.3 V	-	4.0 V	4.3 V	Shut down or below 90% set point.
V <sub>o, set</sub> = 5.0 V	-	5.5 V	6.0 V	

## Output Specifications

Parameter	Min	Typ	Max	Notes
Output Voltage Set Point	-2%V <sub>o, set</sub>	-	2%V <sub>o, set</sub>	V <sub>in</sub> = 12 V, full load
Output Voltage Set Point <sup>1</sup>	-2.5%V <sub>o, set</sub>	-	3.5%V <sub>o, set</sub>	
Load Regulation	-0.7%V <sub>o, set</sub>	0.4%V <sub>o, set</sub>	0.7%V <sub>o, set</sub>	I <sub>o</sub> = I <sub>o, min</sub> to I <sub>o, max</sub>
Line Regulation	-0.7%V <sub>o, set</sub>	0.3%V <sub>o, set</sub>	0.7%V <sub>o, set</sub>	V <sub>in</sub> = V <sub>in, min</sub> to V <sub>in, max</sub>
Regulation Over Temperature (-40 °C to +85 °C)	-	0.5%V <sub>o, set</sub>	-	T <sub>ref</sub> = T <sub>a, min</sub> to T <sub>a, max</sub>
Output Current	0 A	-	6 A	
Current Limit Threshold	6.8 A	-	15 A	
Short Circuit Surge Transient	-	0.25 A <sup>2</sup> s	-	

## NON-ISOLATED DC/DC CONVERTERS

4.5 Vdc -14 Vdc Input    0.75 Vdc - 5.0 Vdc/6 A Output



Jan. 25, 2013

Bel Power, Inc. , a subsidiary of Bel Fuse, Inc.

### Output Specifications(continued)

Parameter	Min	Typ	Max	Notes	
Ripple and Noise (pk-pk)				Tested with 0-20 MHz, with 10 uF/10 V tantalum capacitor & 1 uF/10 V ceramic capacitor at the output	
Vo=5.0 V	-	100 mV	140 mV		
Vo=3.3 V	-	80 mV	120 mV		
Vo=0.75 V	-	35 mV	70 mV		
Ripple and Noise (rms)					
Vo=5.0 V	-	35 mV	50 mV		
Vo=3.3 V	-	25 mV	40 mV		
Vo=0.75 V	-	10 mV	15 mV		
Turn on Time	-	6 mS	12 mS		
Overshoot at Turn on	-	0%	3%		
Output Capacitance					
ESR $\geq$ 1mohm	0 uF	-	1000 uF		
ESR $\geq$ 10mohm	0 uF	-	2200 uF		
<b>Transient Response</b>					
50% ~ 100% Max Load	All outputs	-	200 mV	350 mV	di/dt=2.5 A/uS; Vin=12 V; and with 10 uF/10 V tantalum capacitor & 1uF/10 V ceramic capacitor at the output.
Settling Time		-	25 uS	50 uS	
100% ~ 50% Max Load		-	200 mV	350 mV	
Settling Time		-	25 uS	50 uS	

**Notes:** All specifications are typical at nominal input (Vin=12 V), full load at 25 °C unless otherwise stated.

1. Over all operating input voltages, resistive loads and temperature conditions.

### General Specifications

Parameter	Min	Typ	Max	Notes
Efficiency				Measured at Vin=12 V, full load
Vo=5.0 V	88%	92%	-	
Vo=3.3 V	85%	88%	-	
Vo=1.8 V	80%	84%	-	
Vo=0.75 V	68%	73%	-	
Switching Frequency	220 kHz	250 kHz	280 kHz	
Output Voltage Trim Range (wide trim)	0.7525 V	-	5 V	
MTBF	3,079,469 hours			Calculated Per Bell Core SR-332 (Vin=12 V; Vo=3.3 V, Io=4.8 V; Ta = 25 °C)
Dimensions				Surface Mount
Inches (L x W x H)	0.8 x 0.45 x 0.251			
Millimeters (L x W x H)	20.32 x 11.42 x 6.38			
Dimensions				Vertical Mount
Inches (L x W x H)	1.0 x 0.5 x 0.243			
Millimeters (L x W x H)	25.4 x 12.7 x 6.16			
Weight	-	5 g	-	

**Note:** All specifications are typical at 25 °C unless otherwise stated.

# NON-ISOLATED DC/DC CONVERTERS

4.5 Vdc -14 Vdc Input    0.75 Vdc - 5.0 Vdc/6 A Output



Jan. 25, 2013

Bel Power, Inc. , a subsidiary of Bel Fuse, Inc.

## Control Specifications

Parameter	Min	Typ	Max	Notes
<b>Remote On/Off</b>				
Signal Low (Unit Off)	-0.3 V	-	0.4 V	xRBA-06E2A0; Remote On/Off pin open, Unit on.
Signal High (Unit On)	2.5 V	-	14 V	
Signal Low (Unit On)	-0.3 V	-	0.4 V	xRBA-06E2AL; Remote On/Off pin open, Unit on.
Signal High (Unit Off)	2.5 V	-	14 V	
<b>Voltage Sequencing</b>				
Sequencing Voltage	0.05 V	-	V <sub>in</sub>	Sequencing Voltage should be higher than output voltage.
Sequencing Slew Rate Capability	-	-	2 V/mS	
Sequencing Delay Time	10 mS	-	-	Delay from V <sub>in</sub> , min to application of voltage on SEQ pin
Tracking Accuracy	Power-Up	-	100 mV	
	Power-Down	-	200 mV	

## Output Trim Equations

Equation for calculating the trim resistor (in kΩ) given the desired adjusted voltage (V<sub>adj</sub>) is shown below. The Trim Up resistor should be connected between the Trim pin and Ground.

$$R_{trim} = \frac{10.507}{V_{adj} - 0.7525} - 1$$

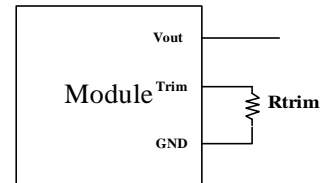

Equation for calculating the trim voltage (in V) given the desired adjusted voltage (V<sub>adj</sub>) is shown below. The Trim Up voltage should be connected between the Trim pin and Ground.

$$V_{trim} = 0.7 - 0.0667 \times (V_{adj} - 0.7525)$$

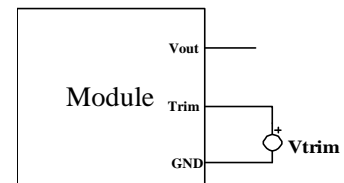

# NON-ISOLATED DC/DC CONVERTERS

4.5 Vdc -14 Vdc Input 0.75 Vdc - 5.0 Vdc/6 A Output



Jan. 25, 2013

Bel Power, Inc. , a subsidiary of Bel Fuse, Inc.

## Efficiency Data

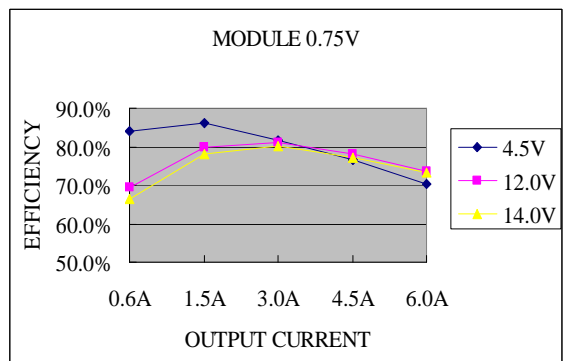
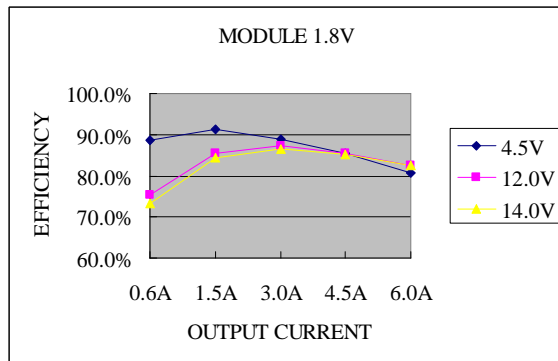
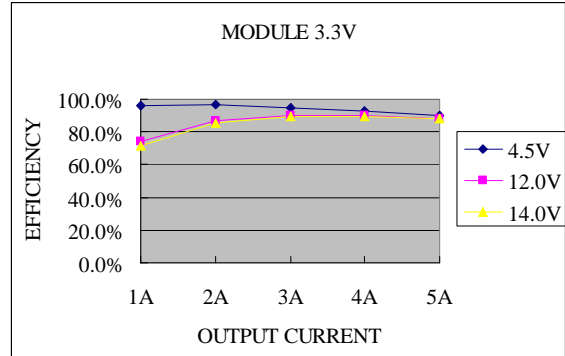
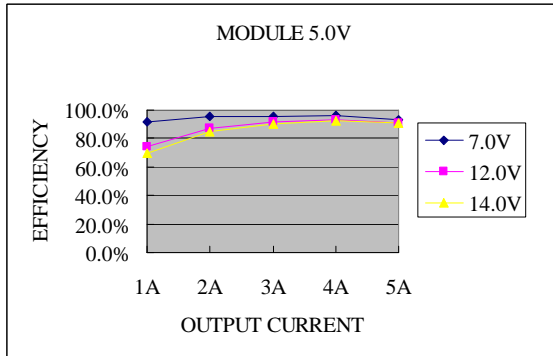

# NON-ISOLATED DC/DC CONVERTERS

4.5 Vdc -14 Vdc Input    0.75 Vdc - 5.0 Vdc/6 A Output



Jan. 25, 2013

Bel Power, Inc., a subsidiary of Bel Fuse, Inc.

## Thermal Derating Curves

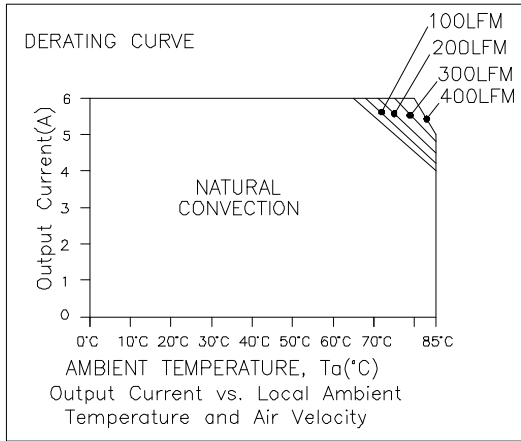

SRBA-06E2Ax, Vo=0.75 V

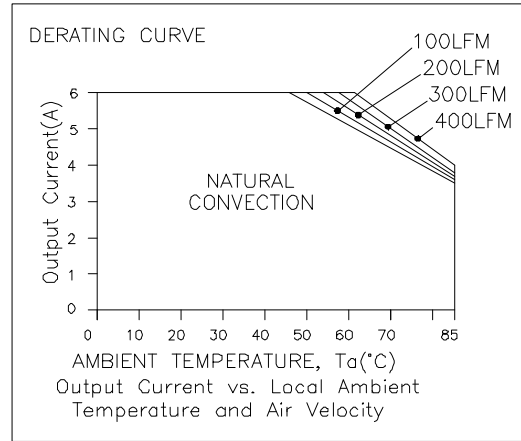

VRBA-06E2Ax, Vo=0.75 V

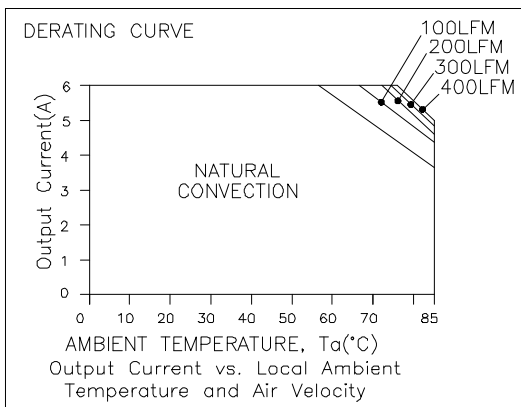

SRBA-06E2Ax, Vo=2.5 V

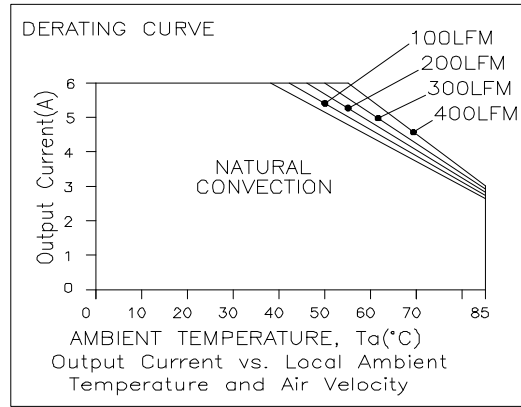

VRBA-06E2Ax, Vo=2.5 V

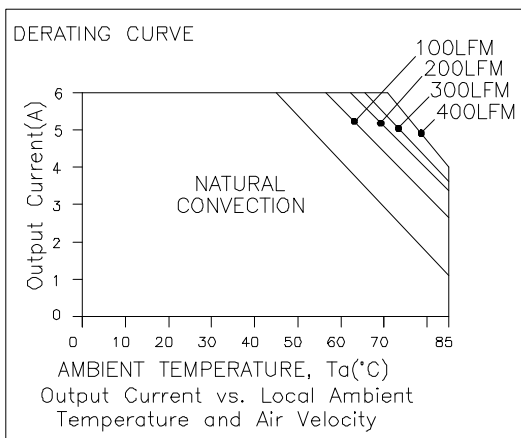

SRBA-06E2Ax, Vo=5.0 V

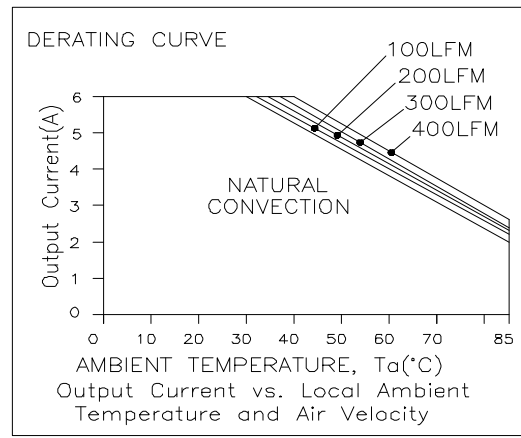

VRBA-06E2Ax, Vo=5.0 V

# NON-ISOLATED DC/DC CONVERTERS

4.5 Vdc -14 Vdc Input    0.75 Vdc - 5.0 Vdc/6 A Output



Jan. 25, 2013

Bel Power, Inc. , a subsidiary of Bel Fuse, Inc.

## Ripple and Noise Waveforms

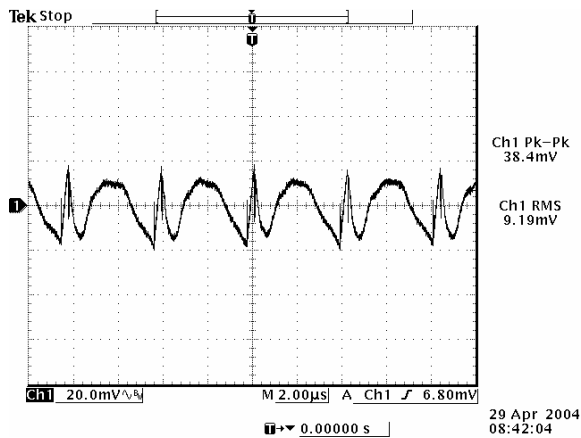

Ripple and noise at full load,  $V_o=0.75$  V

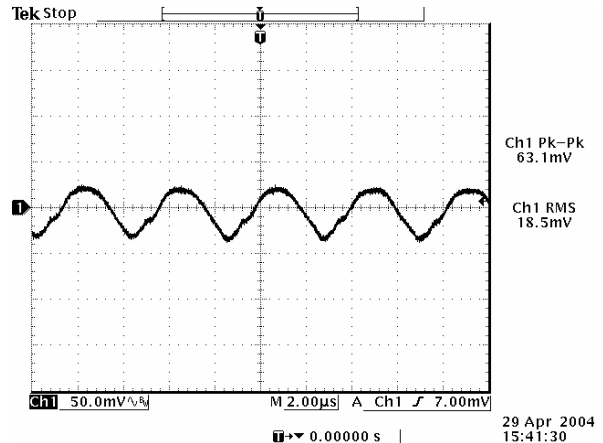

Ripple and noise at full load,  $V_o=1.8$  V

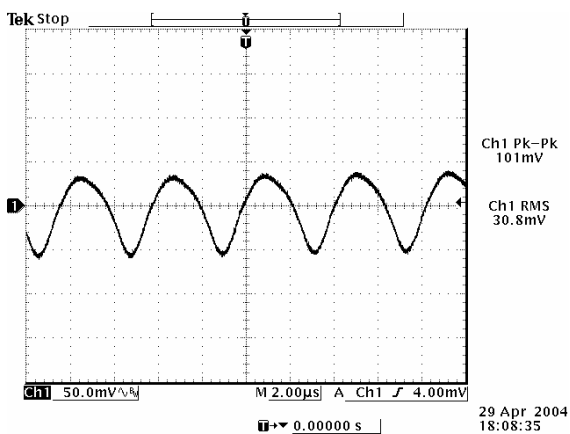

Ripple and noise at full load,  $V_o=3.3$  V

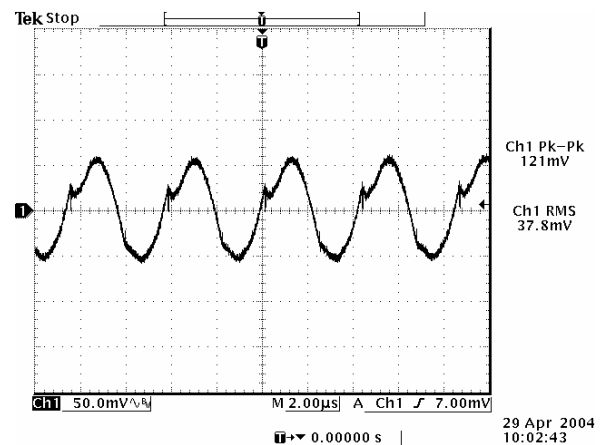

Ripple and noise at full load,  $V_o=5.0$  V

**Note:** Ripple and noise at 12 V input, 0-20 MHz BW, 10  $\mu$ F/10 V tantalum capacitor and 1  $\mu$ F/10 V ceramic capacitor,  $T_a=25$  deg C.

# NON-ISOLATED DC/DC CONVERTERS

4.5 Vdc -14 Vdc Input    0.75 Vdc - 5.0 Vdc/6 A Output



Jan. 25, 2013

Bel Power, Inc., a subsidiary of Bel Fuse, Inc.

## Transient Response Waveforms

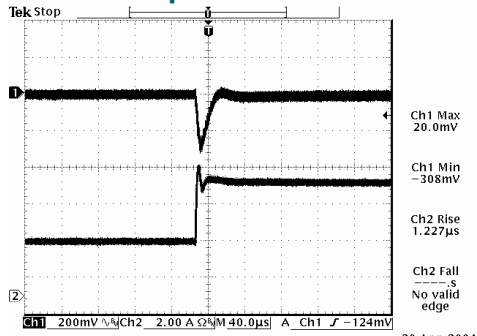

50% to 100% load step at 0.75 V output

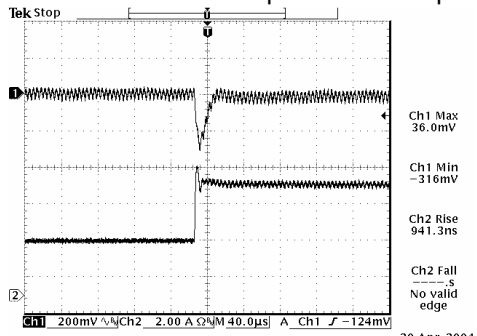

50% to 100% load step at 1.8 V output

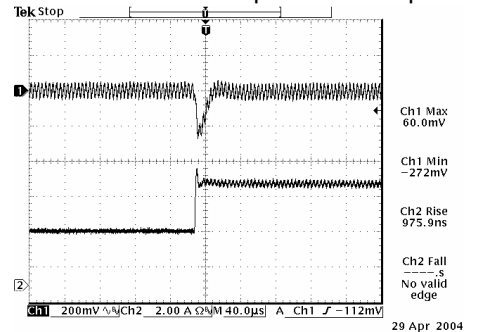

50% to 100% load step at 3.3 V output

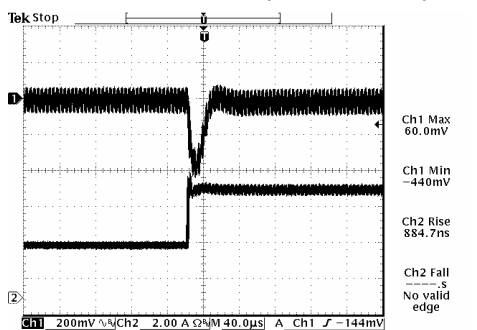

50% to 100% load step at 5.0 V output

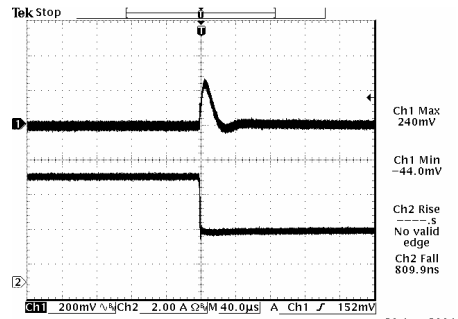

100% to 50% load step at 0.75 V output

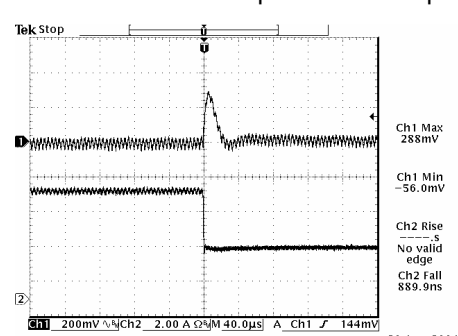

100% to 50% load step at 1.8 V output

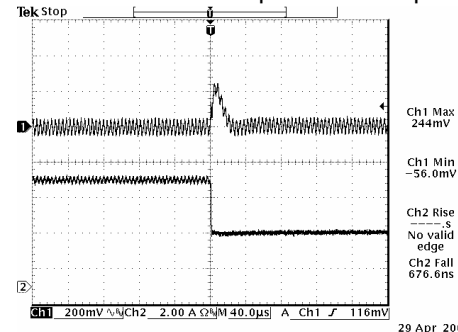

100% to 50% load step at 3.3 V output

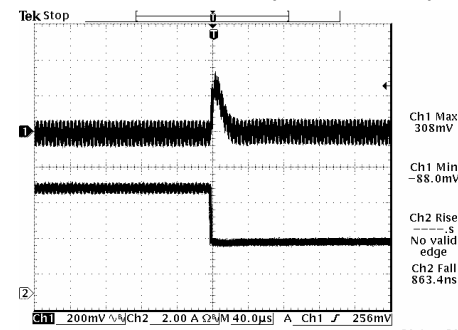

100% to 50% load step at 5.0 V output

**Note:** Transient response at 12 V input, di/dt=2.5 A/uS, with 10 uF/10 V tantalum capacitor and 1uF/10 V ceramic capacitor, and Ta=25 deg C.



# NON-ISOLATED DC/DC CONVERTERS

4.5 Vdc -14 Vdc Input    0.75 Vdc - 5.0 Vdc/6 A Output



Jan. 25, 2013

*Bel Power, Inc. , a subsidiary of Bel Fuse, Inc.*

## Mechanical Outline

### SRBA-06E2Ax

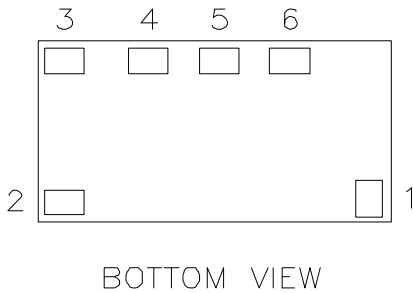
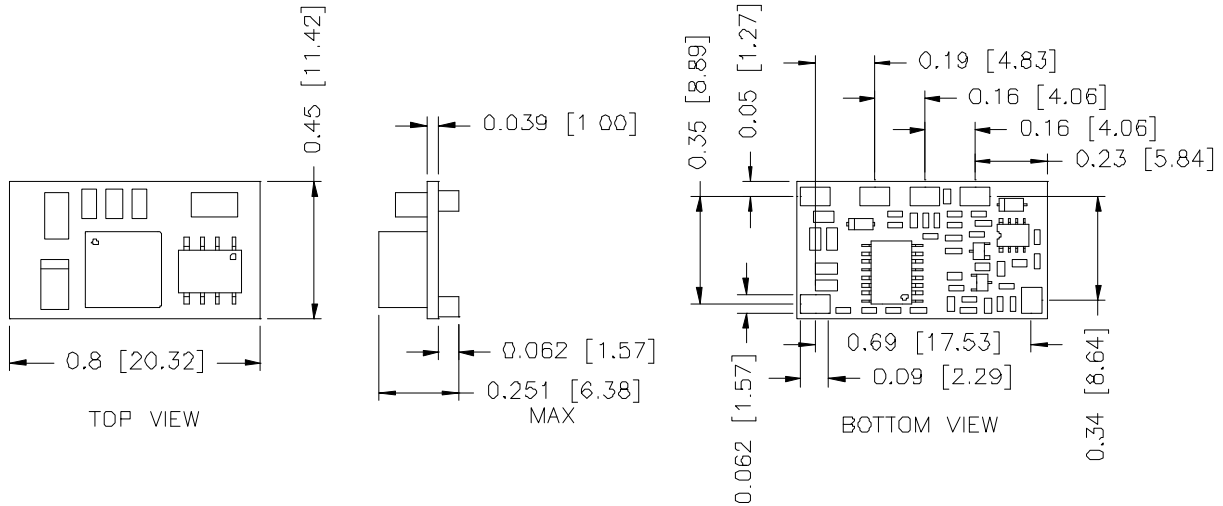

## Pin Connections

Pin	Function
1	Remote On/Off
2	Vin+
3	SEQ
4	Ground
5	Trim
6	Vout+

## RECOMMENDED PAD LAYOUT

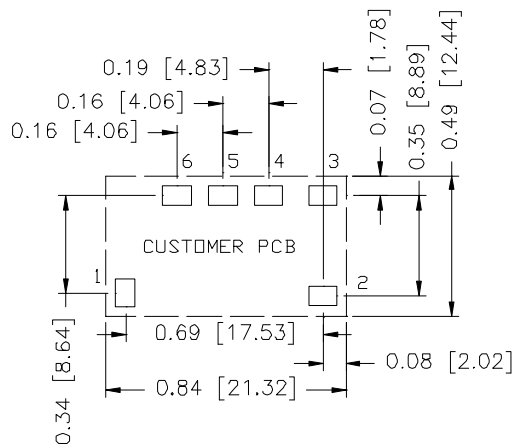

## PAD SIZE:

MIN: 0.12" \* 0.095" (3.05mm \* 2.41mm)

MAX: 0.135" \* 0.11" (3.43mm \* 2.79mm)

# NON-ISOLATED DC/DC CONVERTERS

4.5 Vdc -14 Vdc Input    0.75 Vdc - 5.0 Vdc/6 A Output



Jan. 25, 2013

Bel Power, Inc. , a subsidiary of Bel Fuse, Inc.

## Mechanical Outline (continued)

### VRBA-06E2Ax

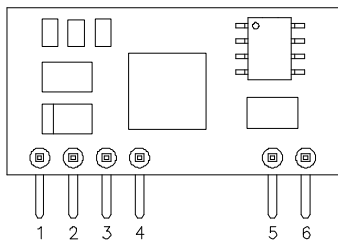
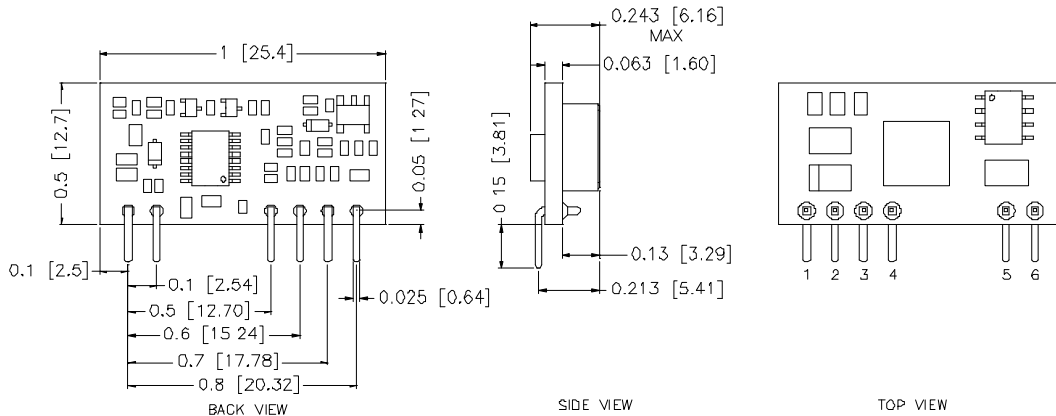

### Pin Connections

Pin	Function
1	Vout+
2	Trim
3	Ground
4	SEQ
5	Vin+
6	Remote On/Off

Recommended Pad Layout for SIP Module

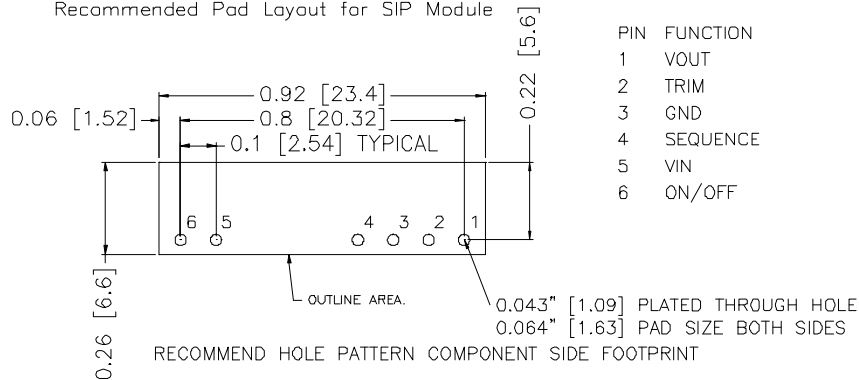

PIN	FUNCTION
1	VOUT
2	TRIM
3	GND
4	SEQUENCE
5	VIN
6	ON/OFF

**Note:** These parts are not however compatible with the higher temperatures associated with lead free solder processes and must be soldered using a reflow profile with a peak temperature of no more than 245 °C.

# NON-ISOLATED DC/DC CONVERTERS

4.5 Vdc -14 Vdc Input    0.75 Vdc - 5.0 Vdc/6 A Output



Jan. 25, 2013

*Bel Power, Inc. , a subsidiary of Bel Fuse, Inc.*

## Revision History

Date	Revision	Changes Detail	Approval
2007-01-12	A	Add a note under P/N Part	Lynn
2008-01-22	B		HL
2011-08-25	C	Update the reflow solder temperature.	HL
2013-01-25	D	Update UL.	HL

### RoHS Compliance

Complies with the European Directive 2002/95/EC, calling for the elimination of lead and other hazardous substances from electronic products.



©2013 Bel Fuse Inc. Specifications subject to change without notice. 012513

#### CORPORATE

**Bel Fuse Inc.**  
206 Van Vorst Street  
Jersey City, NJ 07302  
Tel 201-432-0463  
Fax 201-432-9542  
[www.belfuse.com](http://www.belfuse.com)

#### FAR EAST

**Bel Fuse Ltd.**  
8F/ 8 Luk Hop Street  
San Po Kong  
Kowloon, Hong Kong  
Tel 852-2328-5515  
Fax 852-2352-3706  
[www.belfuse.com](http://www.belfuse.com)

#### EUROPE

**Bel Fuse Europe Ltd.**  
Preston Technology Management Centre  
Marsh Lane, Suite G7, Preston  
Lancashire, PR1 8UD, U.K.  
Tel 44-1772-556601  
Fax 44-1772-888366  
[www.belfuse.com](http://www.belfuse.com)