

SRPE-20E1A0

Non-Isolated DC-DC Converter

The Bel SRPE-20E1A0 is part of the non-isolated dc to dc converter power module series. The module uses a vertical SMT package. This converter is available in a range of output voltages from 0.6 VDC to 2.0 Vdc over a wide range of input voltage ($V_{in} = 4.5 - 13.2$ VDC).

Key Features & Benefits

- 4.5 – 13.2 VDC Input
- 0.6 – 2.0 VDC / 20 A Output
- Non-Isolated
- Wide Output Trim Range
- Fixed Frequency
- Output Over-Voltage Shutdown
- High Efficiency
- OCP/SCP
- High Power Density
- Power Good Signal
- Over Temperature Shutdown
- Remote Sense
- Wide Input Voltage Range
- Remote On/Off
- Low Cost
- Under-Voltage Lockout
- Wide Operating Temperature Range (0 °C - 50 °C)
- Class II, Category 2, Non-Isolated DC/DC Converter (refer to IPC-9592B)

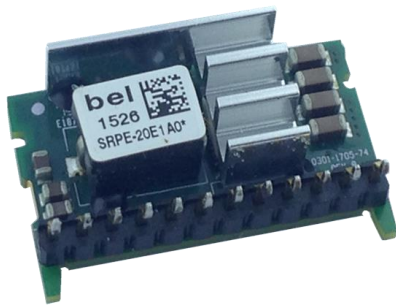

Applications

- Networking
- Computers and Peripherals
- Telecommunications

1. MODEL SELECTION

MODEL NUMBER	OUTPUT VOLTAGE	INPUT VOLTAGE	MAX. OUTPUT CURRENT	MAX. OUTPUT POWER	TYPICAL EFFICIENCY
SRPE-20E1A0G	0.6 – 2.0 VDC	4.5 - 13.2 VDC	20 A	40 W	92%
SRPE-20E1A0R					

PART NUMBER EXPLANATION

S	R	PE	-	20	E	1A	0	x
Mounting Type	RoHS Status	Series Name		Output Current	Input Range	Output Voltage	Active Logic	Package
Surface Mount	RoHS	SMD SIP		20 A	4.5 - 13.2 V	0.6 - 2.0 V	Active High	G – Tray Package R – Tape and Reel Package

2. ABSOLUTE MAXIMUM RATINGS

PARAMETER	DESCRIPTION	MIN	TYP	MAX	UNITS
Continuous non-operating Input Voltage		-0.3	-	15	V
Output Enable Terminal Voltage		-0.3	-	15	V
Ambient Temperature		0	-	50	°C
Storage Temperature		-40	-	125	°C
Altitude		-	-	2000	m

NOTE: Ratings used beyond the maximum ratings may cause a reliability degradation of the converter or may permanently damage the device.

3. INPUT SPECIFICATIONS

PARAMETER	DESCRIPTION	MIN	TYP	MAX	UNIT
Input Voltage		4.5	12	13.2	V
Input Current (full load)		-	-	10.0	A
Input Current (no load)	All Vin, Vout = 0.6 V, at Ta = 25°C.	-	30	50	mA
	All Vin, Vout = 1.2 V, at Ta = 25°C.	-	50	70	
	All Vin, Vout = 2 V, at Ta = 25°C.	-	60	80	
Remote Off Input Current		-	10	-	mA
Input Reflected Ripple Current (rms)	Vout = 2 V, Iout = 20 A. With simulated source impedance of 1 µH, 5 Hz to 20 MHz. Use 100 µF/100 V electrolytic capacitors with ESR < 0.2 ohm max @ 25°C.	-	-	20	mA
Input Reflected Ripple Current (pk-pk)		-	-	100	mA
Turn-on Voltage Threshold		3.8	4.3	5	V
Turn-off Voltage Threshold		3.8	4.1	4.5	V

NOTE: All specifications are typical at 25 °C unless otherwise stated.

4. OUTPUT SPECIFICATIONS

PARAMETER	DESCRIPTION	MIN	TYP	MAX	UNIT
Output Voltage Set Point	$V_{o,set} \geq 0.9$ VDC	-2	-	2	%Vo,set
	$V_{o,set} < 0.9$ VDC	-3	-	3	
Load Regulation	$V_{in} = 12$ V, $I_o = 0 - 20$ A, $T_a = 25^\circ\text{C}$	-2	-	2	%Vo,set
Line Regulation	$V_{in} = 4.5 - 13.2$ V, $I_o = 20$ A, $T_a = 25^\circ\text{C}$	-2	-	2	%Vo,set
Regulation Over Temperature		-	± 3	-	%Vo,set
Output Ripple and Noise (pk-pk)	Condition: $V_{in} = 12$ V, $I_{out} = \text{full load}$, $T_a = 25^\circ\text{C}$; measured with a $10 \mu\text{F} + 7 \times 100 \mu\text{F}$ ceramic cap and $3 \times 470 \mu\text{F}$ POSCAP ESR ≤ 12 m ohm at output.	-	-	30	mV
Output Ripple and Noise (rms)		-	-	5	mV
Output Current Range		0	-	20	A
Output DC Current Limit		22	-	39	A
Turn On Time		-	-	5	ms
Overshoot at Turn On		-	0	5	%
Output Capacitance	Required $C_{out_min} = 470 \mu\text{F}$ with ESR ≤ 12 m ohm.	470	-	6000	μF
TRANSIENT RESPONSE					
ΔV 50% ~ 75% of Max Load	Overshoot	-	25	40	mV
	Settling Time	-	20	40	μs
ΔV 75% ~ 50% of Max Load	Overshoot	-	25	40	mV
	Settling Time	-	20	40	μs

NOTE: All specifications are typical, at 25°C unless otherwise stated.

5. GENERAL SPECIFICATIONS

PARAMETER	DESCRIPTION	MIN	TYP	MAX	UNIT
Efficiency	$V_o = 0.6\text{ V}$, $I_o = 20\text{ A}$	82	83.6	-	%
	$V_o = 1.2\text{ V}$, $I_o = 20\text{ A}$	88	89.3	-	
	$V_o = 2.0\text{ V}$, $I_o = 20\text{ A}$	91	92.2	-	
Switching Frequency		-	500	-	kHz
Over Temperature Protection		-	125	-	°C
Output Voltage Trim Range (Wide Trim)	This voltage is achieved by trimming up output slowly.	0.6	-	2	V
Weight		-	6.8	-	g
MTBF	Calculated Per Telcordia SR-332, Issue 3 ($V_{in} = 12\text{ V}$, $V_o = 0.9\text{ V}$, $I_o = 20\text{ A}$, $T_a = 40^\circ\text{C}$, with 300 LFM, FIT = $10^9/\text{MTBF}$)	-	88.4	-	Mhrs
FIT		-	11.3	-	-
Dimensions (L x W x H)			1.20 x 0.43 x 0.65		inch
			30.48 x 10.92 x 16.51		mm

NOTE: All specifications are typical, at 25°C unless otherwise stated.

6. REMOTE ON/OFF

PARAMETER	DESCRIPTION	MIN	TYP	MAX	UNIT
Signal Low (Unit Off)	Remote On/Off pin open, unit off.	0	-	0.5	V
Signal High (Unit On)		1.8	-	15	V

7. EFFICIENCY DATA

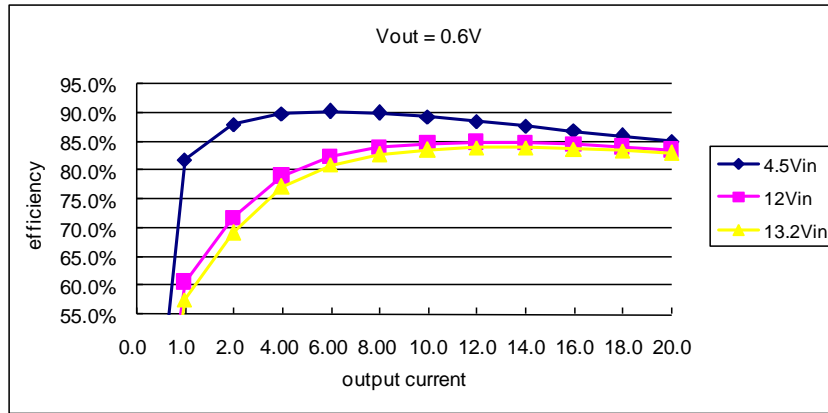

Figure 1. Efficiency @ Vo = 0.6 V

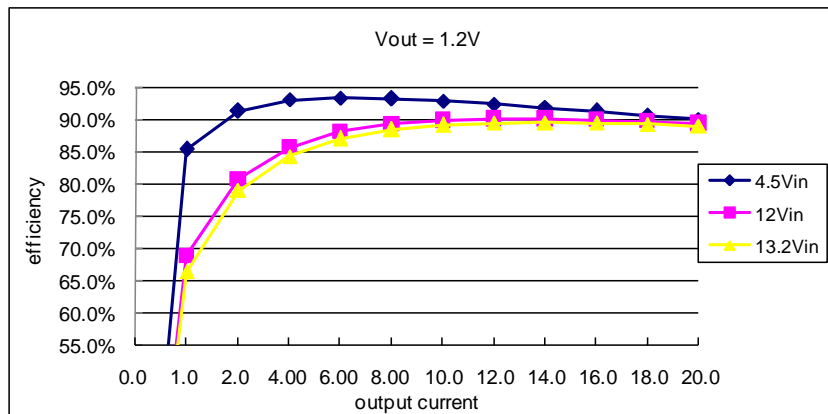

Figure 2. Efficiency @ Vo = 1.2 V

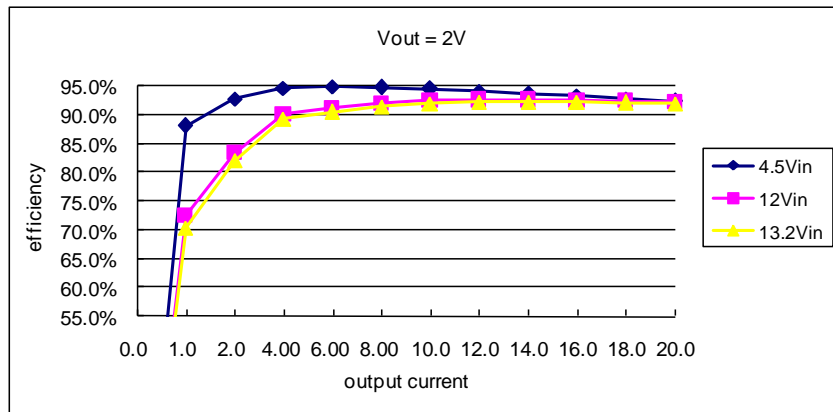

Figure 3. Efficiency @ $V_o = 2.0\text{ V}$

8. INPUT NOISE

Input Reflected Ripple Current

Testing setup

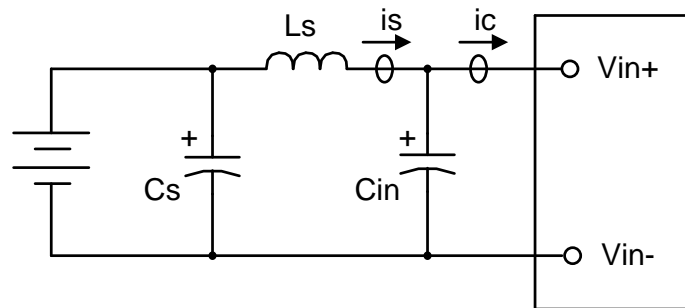

Figure 4. Test setup

Notes and values in testing:

is: Input Reflected Ripple Current

ic: Input Terminal Ripple Current

Ls: Simulated Source Impedance (1 μH)

Cs: Offset possible source Impedance (100 μF , ESR < 0.2 Ω @ 100 kHz, 20 $^\circ\text{C}$)

Cin: Electrolytic capacitor, should be as close as possible to the power module to damp ic ripple current and enhance stability. Recommendation: 100 μF , ESR < 0.2 Ω @ 100 kHz, 20 $^\circ\text{C}$.

Below measured waveforms are based on above simulated and recommended inductance and capacitance.

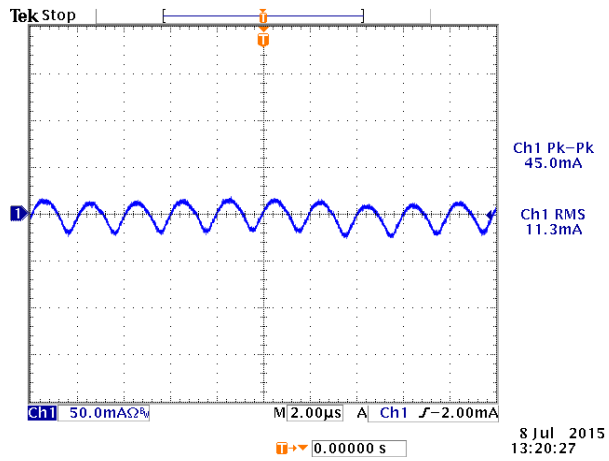

Figure 5. i_s (input terminal ripple current), AC component

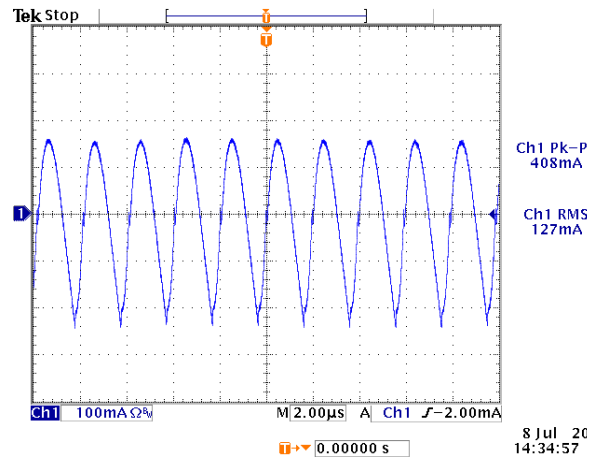

Figure 6. i_c (input terminal ripple current), AC component

NOTE: $V_{in} = 12\text{ V}$, $V_o = 2\text{ V}$, $I_o = 20\text{ A}$, with $1 \times 10\text{ }\mu\text{F}$ ceramic and $1 \times 470\text{ }\mu\text{F}$ polymer capacitor at the output, $T_a = 25^\circ\text{C}$.

9. THERMAL DERATING CURVE

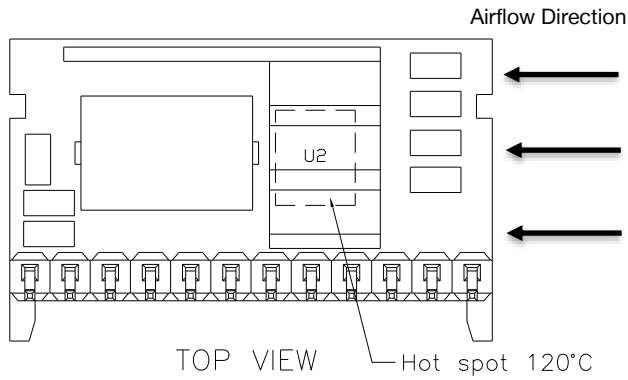

Figure 7. Airflow direction, Hot spot location and allowed maximum temperature

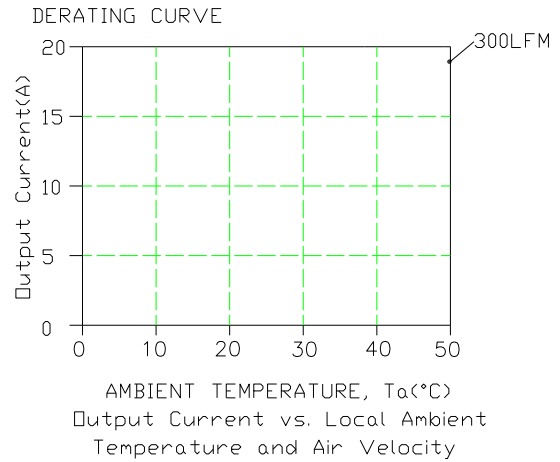

Figure 8. $V_{in} = 12 V$, $V_o = 0.6 - 2 V$

10. INPUT UNDER-VOLTAGE LOCKOUT

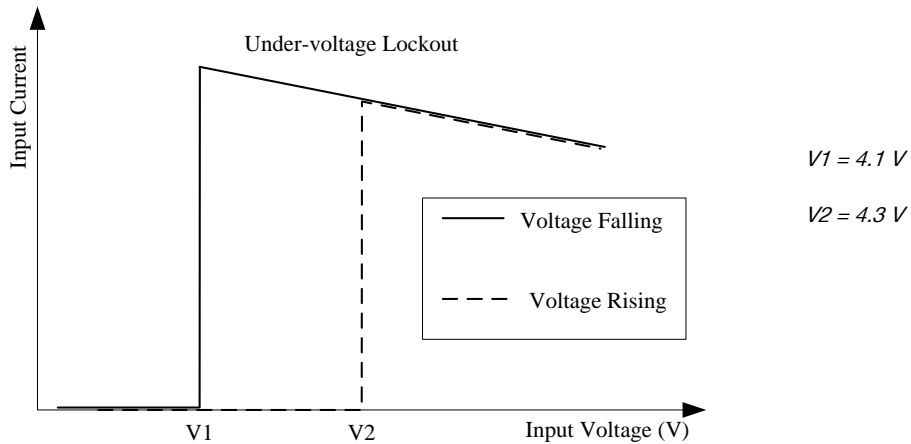

Figure 9. Input under-voltage lockout

11. RIPPLE AND NOISE WAVEFORM

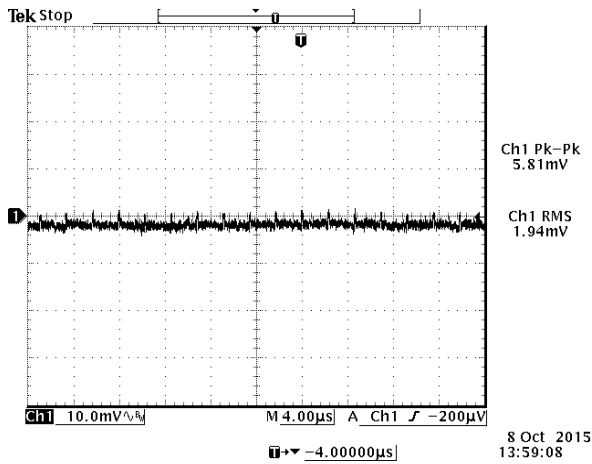

Figure 10. Ripple and noise at full load, 12 VDC input
0.6 VDC / 20 A output and $T_a = 25^\circ\text{C}$

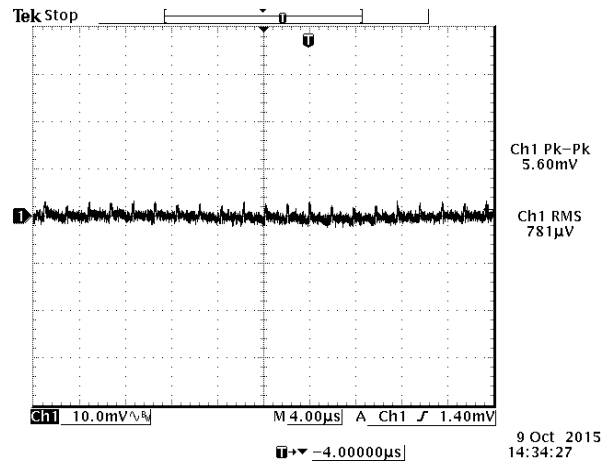

Figure 11. Ripple and noise at full load, 12 VDC input
0.9 VDC / 20 A output and $T_a = 25^\circ\text{C}$

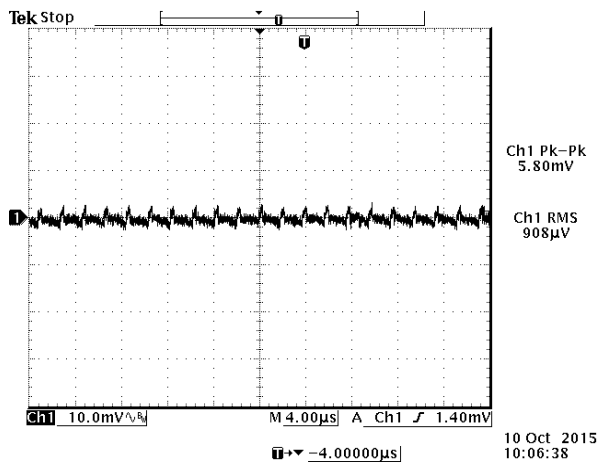

Figure 12. Ripple and noise at full load, 12 VDC input
2.0 VDC / 20 A output and $T_a = 25^\circ\text{C}$

NOTE: Test condition of the output ripple and noise:
0-20 MHz BW, with a 10 µF+7*100 µF ceramic cap and 3*470 µF POSCAP ESR ≤ 12 m ohm at output.

12. TRANSIENT RESPONSE WAVEFORMS

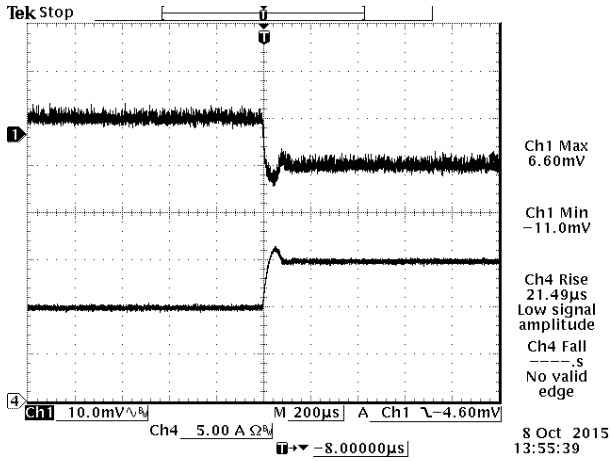

Figure 13. $V_{in} = 50\% - 75\%$ Load Transient at $V_{in} = 12\text{ VDC}$
 $V_{out} = 0.6\text{ VDC}$ @ $T_a = 25^\circ\text{C}$

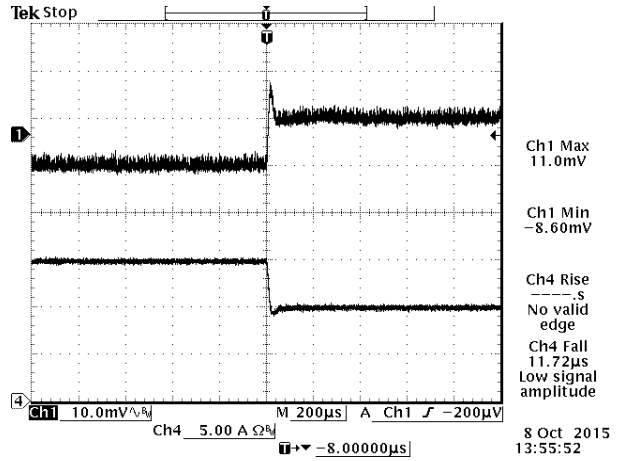

Figure 14. $V_{in} = 75\% - 50\%$ Load Transient at $V_{in} = 12\text{ VDC}$
 $V_{out} = 0.6\text{ VDC}$ @ $T_a = 25^\circ\text{C}$

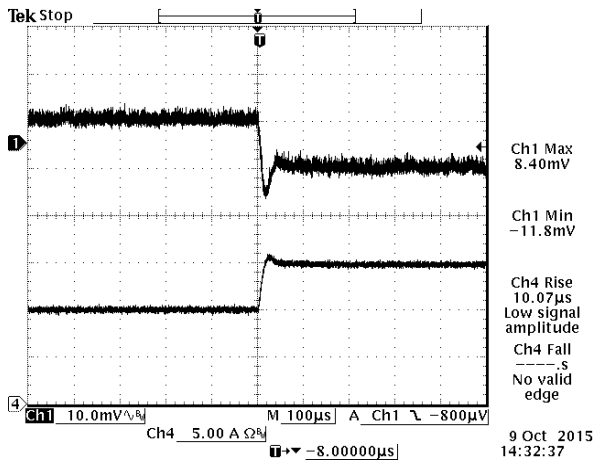

Figure 15. $V_{in} = 50\% - 75\%$ Load Transient at $V_{in} = 12\text{ VDC}$
 $V_{out} = 0.9\text{ VDC}$ @ $T_a = 25^\circ\text{C}$

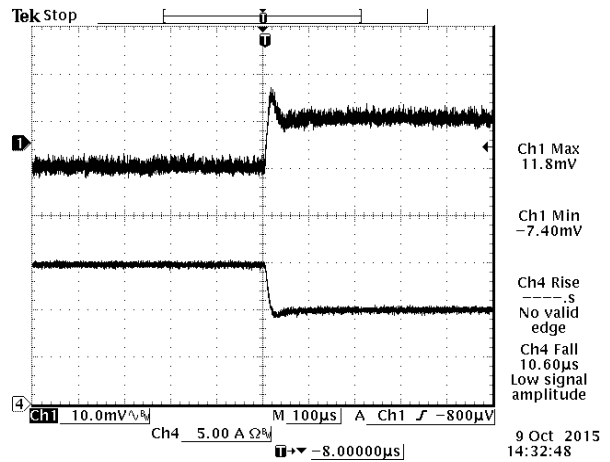

Figure 16. $V_{in} = 75\% - 50\%$ Load Transient at $V_{in} = 12\text{ VDC}$
 $V_{out} = 0.9\text{ VDC}$ @ $T_a = 25^\circ\text{C}$

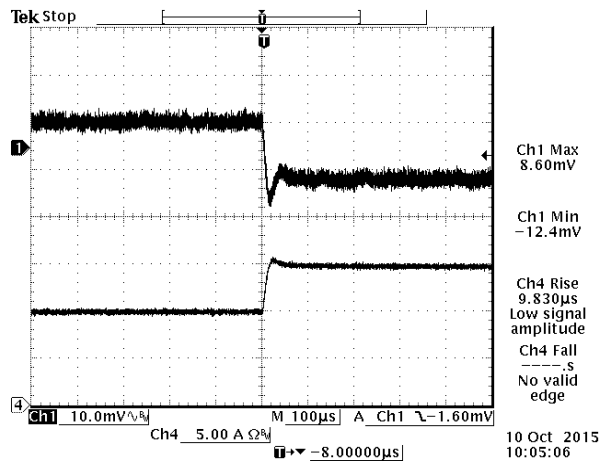

Figure 17. V_{in} =50%-75% Load Transient at $V_{in} = 12$ VDC
 $V_{out} = 2.0$ VDC @ $T_a = 25^\circ\text{C}$

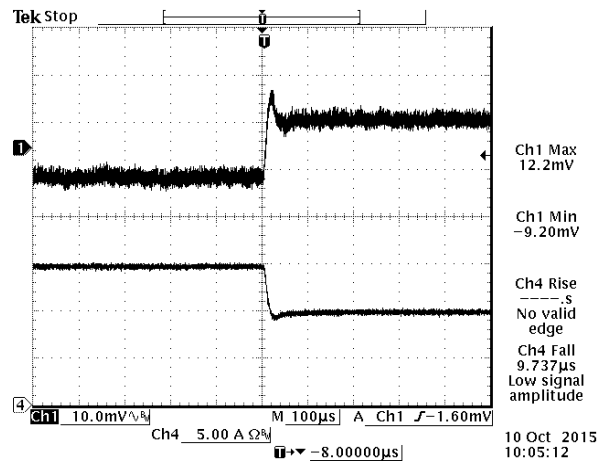

Figure 18. $V_{in} = 75\% - 50\%$ Load Transient at $V_{in} = 12$ VDC
 $V_{out} = 2.0$ VDC @ $T_a = 25^\circ\text{C}$

NOTE: Test condition of the Transient response:
 $di/dt = 2.5$ A/ μs , with a $10 \mu\text{F} + 7 \times 100 \mu\text{F}$ ceramic cap and $3 \times 470 \mu\text{F}$ POSCAP ESR ≤ 12 m ohm at output.

13. STARTUP & SHUTDOWN

RISE TIME

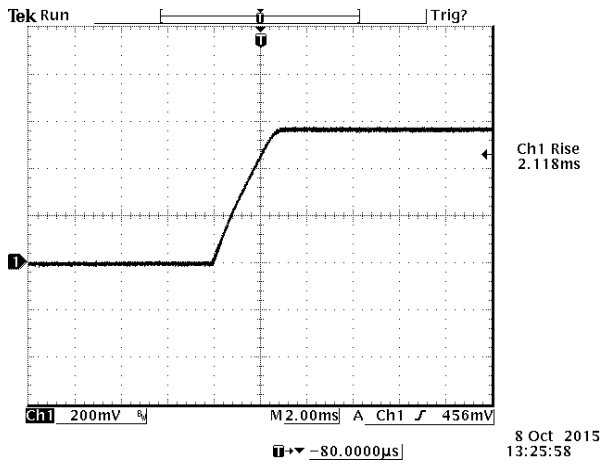

Figure 19. Rise time at full load, 12 VDC input
0.6 VDC / 20 A output and $T_a = 25^\circ\text{C}$

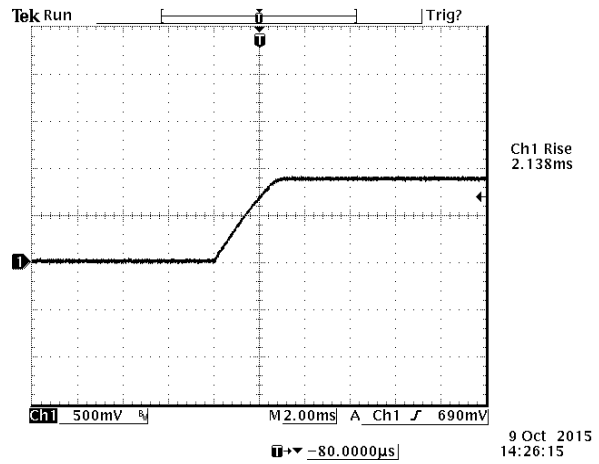

Figure 20. Rise time at full load, 12 VDC input
0.9 VDC / 20 A output and $T_a = 25^\circ\text{C}$

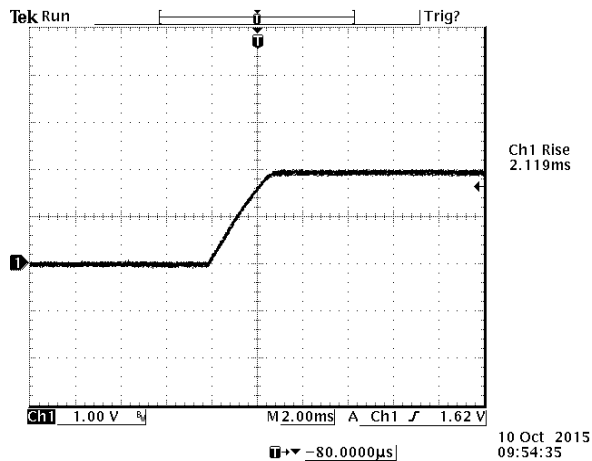

Figure 21. Rise time at full load, 12 VDC input
2.0 VDC / 20 A output and $T_a = 25^\circ\text{C}$

NOTE: Test condition of the Rise time:

$di/dt = 2.5 \text{ A}/\mu\text{s}$, with a $10 \mu\text{F} + 7 \times 100 \mu\text{F}$ ceramic cap and $3 \times 470 \mu\text{F}$ POSCAP ESR $\leq 12 \text{ m}\Omega$ at output.

STARTUP TIME

Startup from remote on/off

Ch1: Vo

Ch3: remote on/off

Test Condition:

With a 10 μ F+7*100 μ F ceramic cap and 3*470 μ F POSCAP ESR \leq 12 m ohm at output.

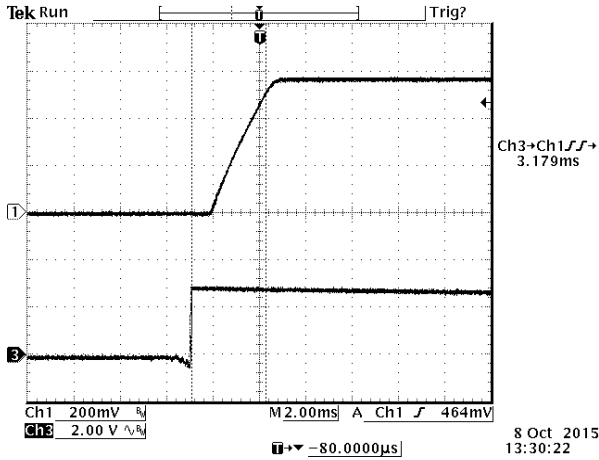

Figure 22. Startup time at full load, 12 VDC input
0.6 VDC / 20 A output and Ta = 25°C

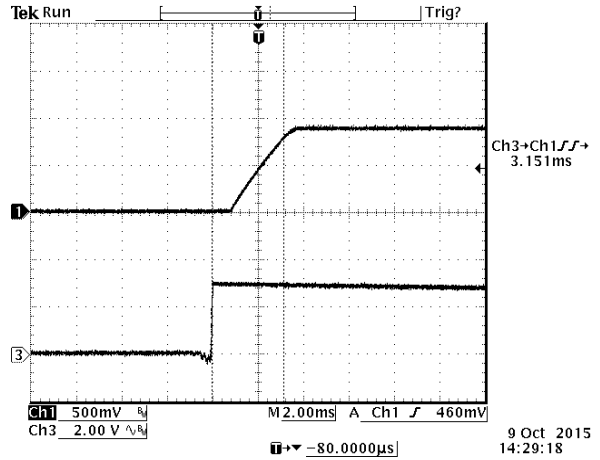

Figure 23. Startup time at full load, 12 VDC input
0.9 VDC / 20 A output and Ta = 25°C

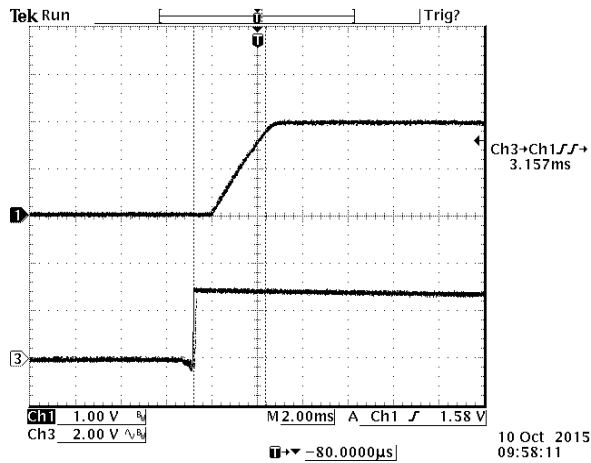

Figure 24. Startup time at full load, 12 VDC input
2.0 VDC / 20 A output and Ta = 25°C

14. TRIM

Output Voltage Set-Point Adjustment
 Maximum trim up voltage is 2 V.
 Minimum trim up voltage is 0.6 V.

Trim up circuit (using an external resistor)

Equations for calculating the trim resistor are shown below.
 The Trim Up resistor should be connected between the Trim pin and the GND.

SRP1-20E1A0 Trim up Resistor Calculate Unit: kΩ
Vo is the desired output voltage.
Rtrimup is the required resistance between TRIM and GND.

$$R_{trimup} = \frac{1.2}{V_o - 0.6}$$

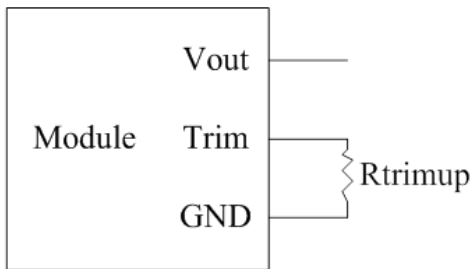

Figure 25. Trim up circuit (using an external resistor)

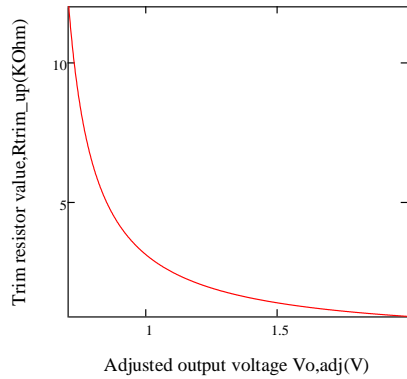

Figure 26. Trim up curve

Trim up circuit (using external PWM signal)

Equations for calculating the duty cycle are shown below

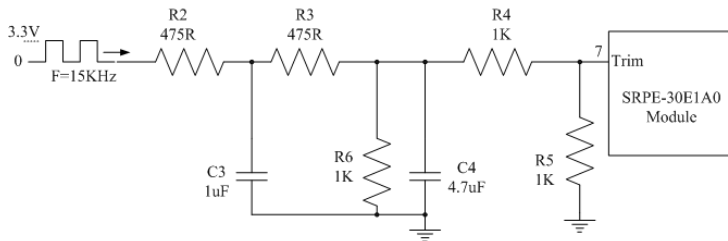

Figure 27. Trim up circuit (using external PWM signal)

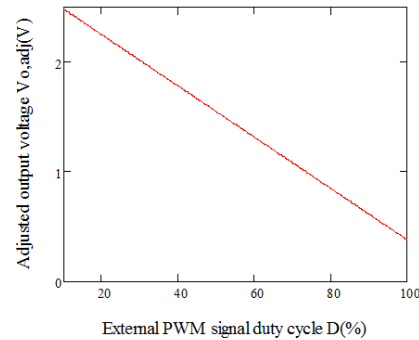

Figure 28. External PWM signal duty cycle

SRP1-20E1A0 Trim up duty cycle Calculate Unit: %

$$V_o(D) = 2.72 - 0.0234D$$

Vo is the desired output voltage.
D is the external PWM signal duty cycle.

15. OVER CURRENT PROTECTION

To provide protection in a fault output overload condition, the module is equipped with internal current-limiting circuitry which can endure current limiting for a few milliseconds. If the over current condition persists beyond a few milliseconds, the module will shut down into hiccup mode and restart once every 40 ms. The module operates normally when the output current goes into specified range. The typical average output current is 3.5 A during hiccup.

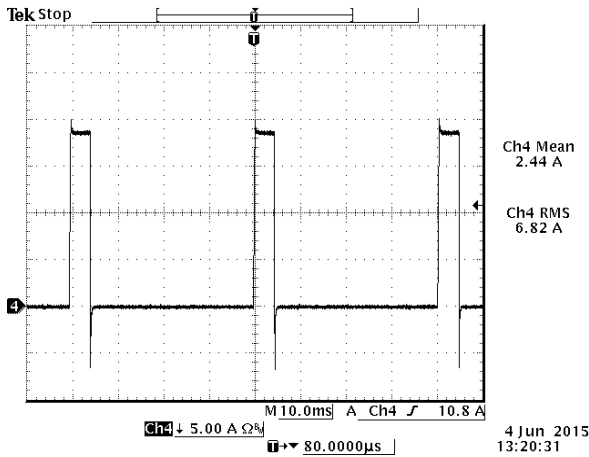

Figure 29. Output current @ SCP, $V_{in} = 12\text{ V}$
 $V_{out} = 0.6\text{ V}$, $T_a = 25^\circ\text{C}$

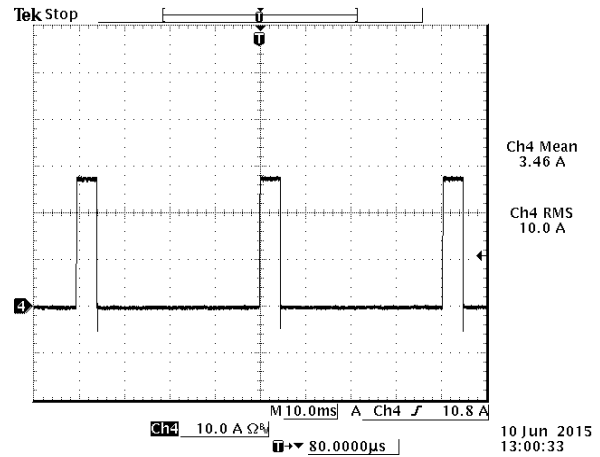

Figure 30. Output current @ SCP, $V_{in} = 12\text{ V}$
 $V_{out} = 0.9\text{ V}$, $T_a = 25^\circ\text{C}$

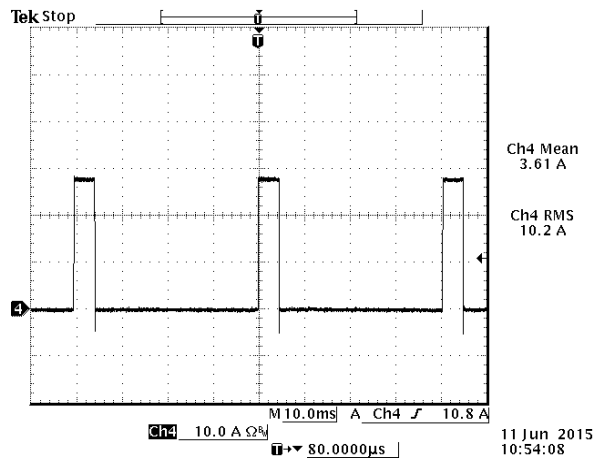

Figure 31. Output current @ SCP, $V_{in} = 12\text{ V}$,
 $V_{out} = 2.0\text{ V}$, $T_a = 25^\circ\text{C}$

NOTE: Test condition of the SCP:

With a 10 μF ceramic cap and a 470 μF POSCAP ESR $\leq 12\text{ m ohm}$ at output.



Asia-Pacific
+86 755 298 85888

Europe, Middle East
+353 61 49 8941

North America
+1 866 513 2839

16. POWER GOOD

1. This module has a power good indicator output. Power good pin used positive logic and is open collector.
2. The maximum voltage pulled up externally on Power Good pin should not exceed 7 V.
3. If the output voltage becomes within +10% and -5% of the target value, internal comparators detect power-good state and the power-good signal becomes high after a 1 ms internal delay.
4. If the output voltage goes outside of +15% or -10% of the target value, the power-good signal becomes low after two microsecond (2- μ s) internal delay.
5. The pull up resistance must be larger than 10 k ohm.

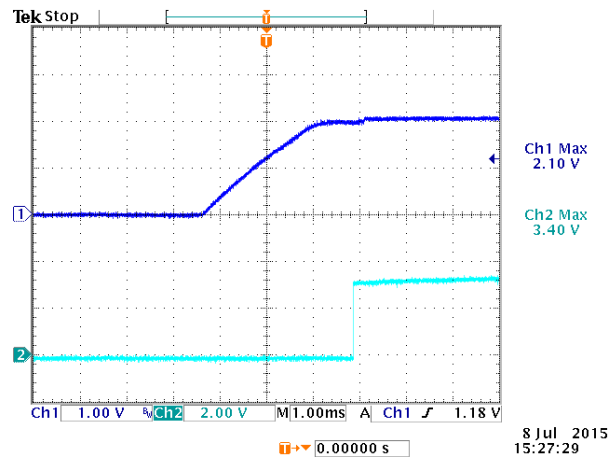

Figure 32. Typical Start-up using Remote on/off,
 $V_{in} = 12\text{ V}$, $V_o = 2\text{ V}$, $I_o = 0\text{ A}$
 CH1: Vout; CH2: PG

17. SOLDERING INFORMATION

The SRPE-20E1A0 modules are designed to be compatible with reflow soldering process. The suggested Pb-free solder paste is Sn/Ag/Cu(SAC). The recommended reflow profile using Sn/Ag/Cu solder is shown in the following. Recommended reflow peak temperature is 245°C while the part can withstand peak temperature of 260°C maximum for 10 seconds. This profile should be used only as a guideline. Many other factors influence the success of SMT reflow soldering. Since your production environment may differ, please thoroughly review these guidelines with your process engineers.

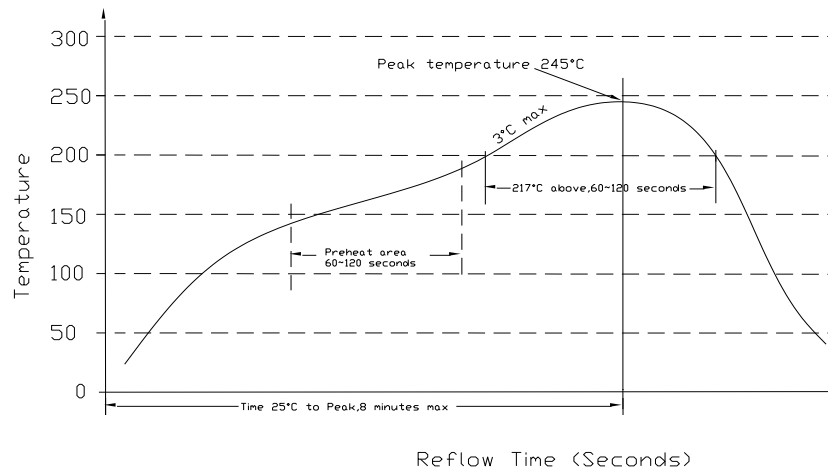

Figure 33. Soldering information

18. MSL RATING

The SRPE-20E1A0 modules have a MSL rating of 3.

19. STORAGE AND HANDLING

The SRPE-20E1A0 modules are designed to be compatible with J-STD-033 Rev: A (Handling, Packing, Shipping and Use of Moisture /Reflow Sensitive surface Mount devices). Moisture barrier bags (MBB) with desiccant are applied. The recommended storage environment and handling procedure is detailed in J-STD-033.

20. PRE-BAKING

This component has been designed, handled, and packaged ready for Pb-free reflow soldering. If the assembly shop follows J-STD-033 guidelines, no pre-bake of this component is required before being reflowed to a PCB. However, if the J-STD-033 guidelines are not followed by the assembler, Bel recommends that the modules should be pre-baked @ 120~125°C for a minimum of 4 hours (preferably 24 hours) before reflow soldering.



Asia-Pacific
+86 755 298 85888

Europe, Middle East
+353 61 49 8941

North America
+1 866 513 2839

21. MECHANICAL OUTLINE
OUTLINE

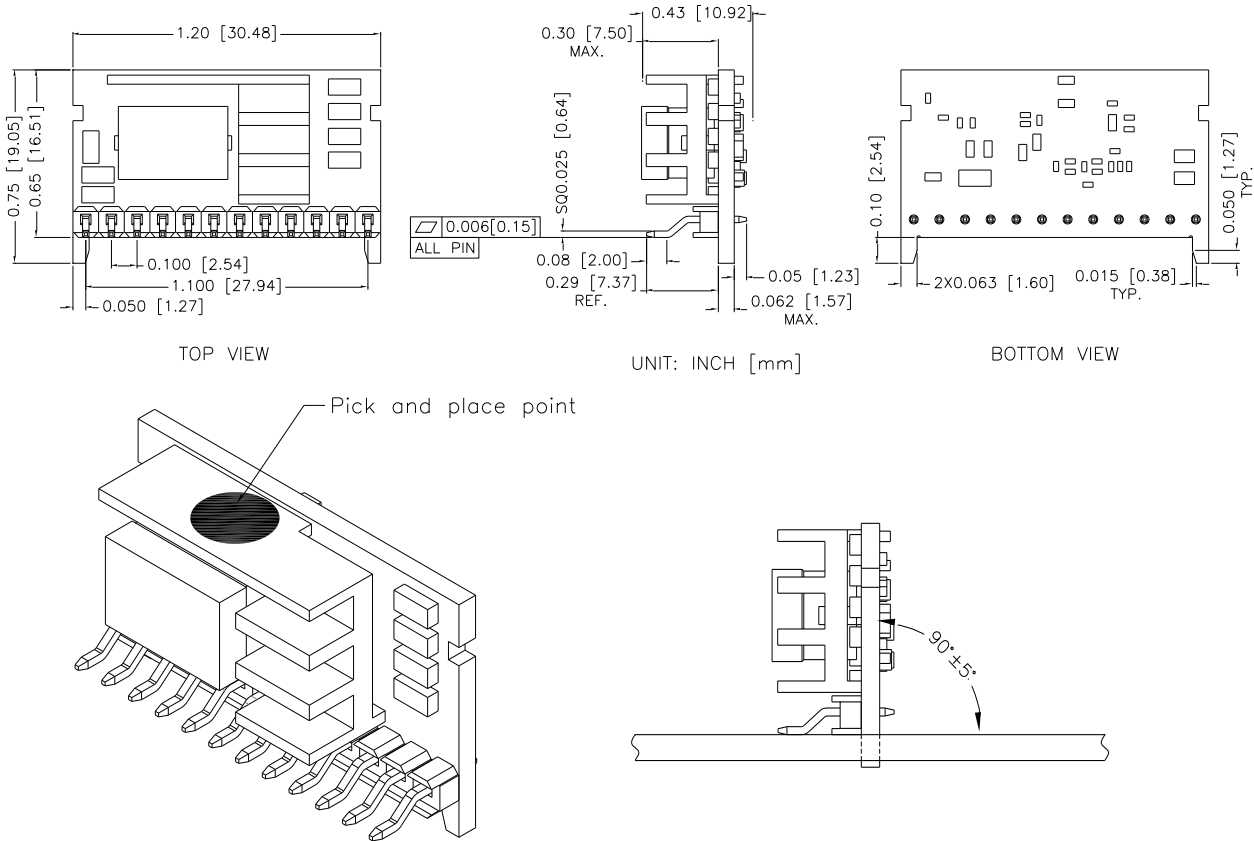

Figure 34. Outline

- NOTE:** 1) All Pins: Material - Copper Alloy;
Finish – 3 micro inches minimum Gold over 50 micro inches minimum Nickel plate
- 2) Un-dimensioned components are shown for visual reference only.
- 3) All dimensions in inch [mm]; Tolerances: x.xx +/-0.02 inch [0.51 mm]; x.xxx +/-0.010 inch [0.25 mm].

22. REVISION HISTORY

DATE	REVISION	CHANGES DETAIL	APPROVAL
2013-08-19	PA	First release	J.Yan
2013-10-10	PB	Update mechanical drawing	J.Yan
2014-01-10	PC	Update input / output spec, efficiency, remote on/off and mechanical drawing.	J.Yan
2014-04-17	PD	Update input specs, output specs, general, efficiency, NR, TR, start up and SCP.	J.Yan
2014-07-03	PE	Update part number explanation, RoHS compliance, Add MD Note.	J.Yan
2014-07-10	PF	Update Cover, mechanical drawing	J.Yan
2014-07-29	G	Added assembly guide drawing	J.Yan
2014-11-18	H	Added trim resistor equation	J.Yan
2015-07-21	I	Input specs: 1. Update no load input current. 2. Update input reflected ripple current. 3. Update turn on voltage threshold: min value 3.8V, typical value 4.3V, max value 5V. 4. Update turn off voltage threshold: min value 3.8V, typical value 4.1V, max value 4.5V. Output specs: 1. Change output voltage set point max to 10%Vo, change the min to -5%Vo. 2. Update the load/line regulation range as $\pm 5\%V_o$. 3. Change output ripple and noise max value to 30mV. 4. Change output DC current limit max value to 39A. 5. Update transient response. 6. Add the regulation over temperature. General: 1. Update the efficiency. Include efficiency data and graph. 2. Update the weight of module. Update the UVLO, TD, TR, OCP. Add the input noise. Add the PG signal section. Update mechanical drawing, change the thickness of module to 0.402 inch.	J.Yan
2015-11-16	J	Output specs : Shrink the output voltage set point, line regulation, load regulation range. Update the waveform of ripple and noise/transient response/Startup&Shutdown. Add tilt dimension in mechanical drawing, update recommended pad layout.	J.Yan
2016-01-05	K	Output specs : Shrink the output voltage set point, line regulation, load regulation range.	J.Yan
2016-01-22	L	Update MTBF, FIT.	J.Yan
2016-05-17	M	Add hot spot location.	J.Yan
2018-02-11	AN	Update the form.	F.Tao
2021-06-29	AP	Add object ID. Add thermal test airflow direction.	XF.Jiang

For more information on these products consult: tech.support@psbel.com

NUCLEAR AND MEDICAL APPLICATIONS - Products are not designed or intended for use as critical components in life support systems, equipment used in hazardous environments, or nuclear control systems.

TECHNICAL REVISIONS - The appearance of products, including safety agency certifications pictured on labels, may change depending on the date manufactured. Specifications are subject to change without notice.



tech.support@psbel.com
belfuse.com/power-solutions