

THE INFORMATION CONTAINED HEREON IS THE PROPERTY OF EMERSON NETWORK POWER, RECEIPT, POSSESSION OR TRANSMITTAL OF THIS DRAWING DOES NOT LICENSE OR IMPLY ANY RIGHT TO USE, SELL, PROTOTYPE OR MANUFACTURE FROM THIS INFORMATION. NO REPRODUCTIONS OR PUBLICATION OF THIS INFORMATION, IN WHOLE OR IN PART, SHALL BE MADE WITHOUT WRITTEN AUTHORIZATION FROM EMERSON NETWORK POWER.

DWG NO. TAI-250 SH 1

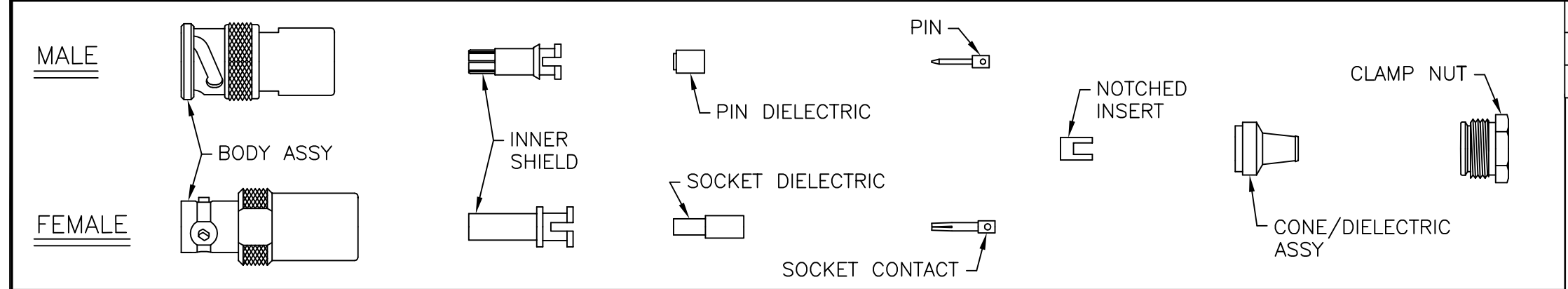

REVISIONS			
REV	DESCRIPTION	DATE	APPROVED
A	ECO 52703	11/15/10	C. MONAHAN

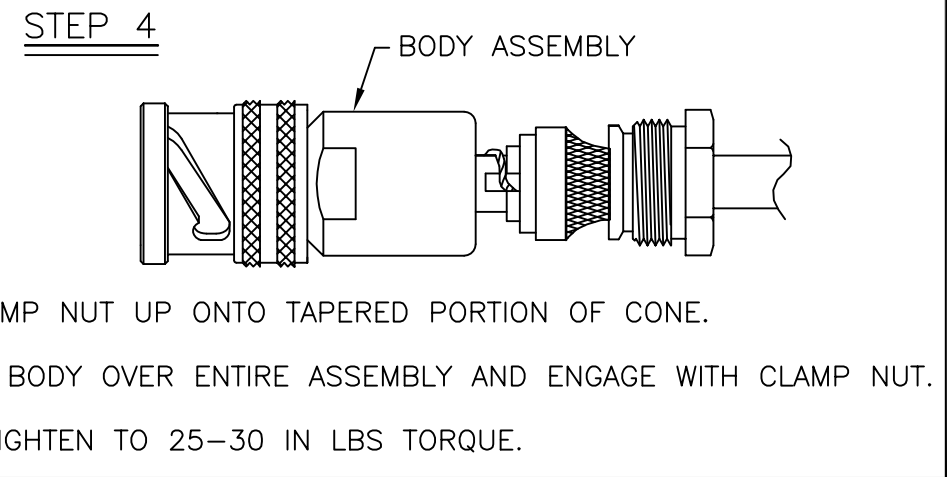
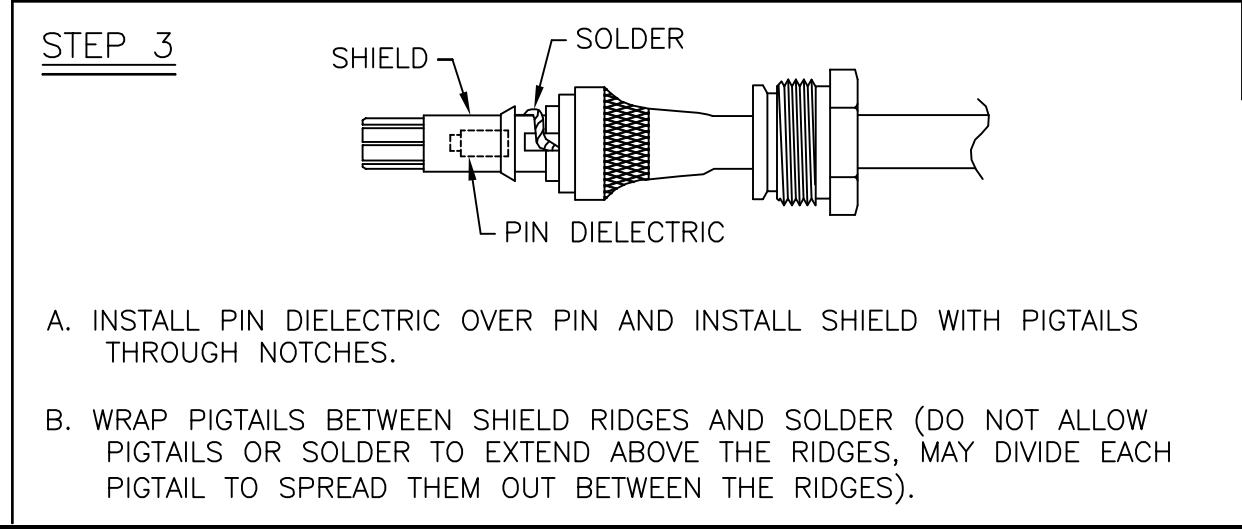
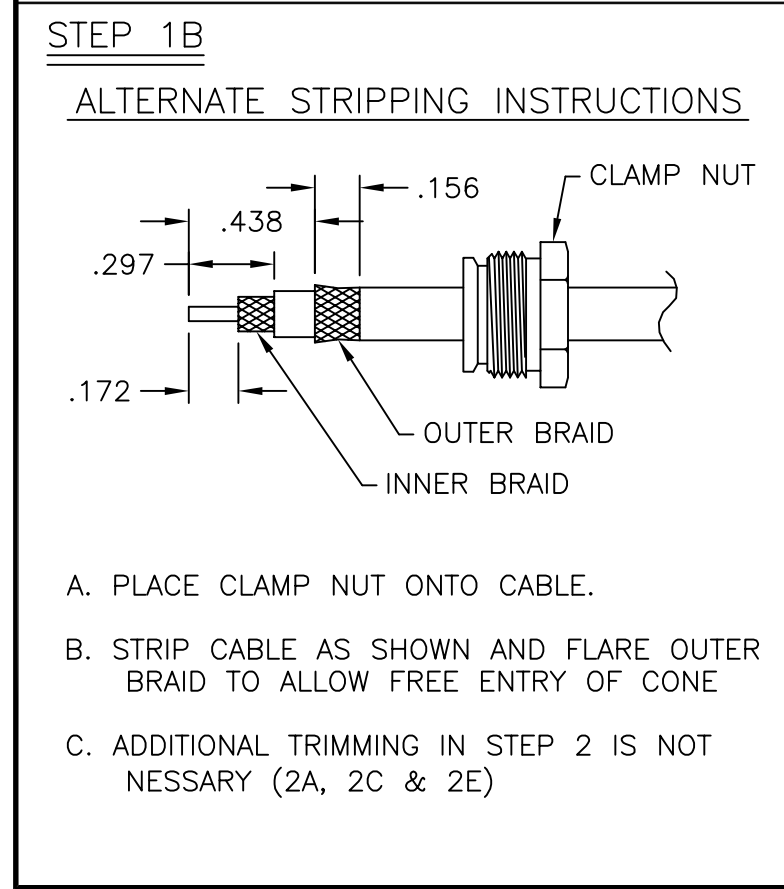
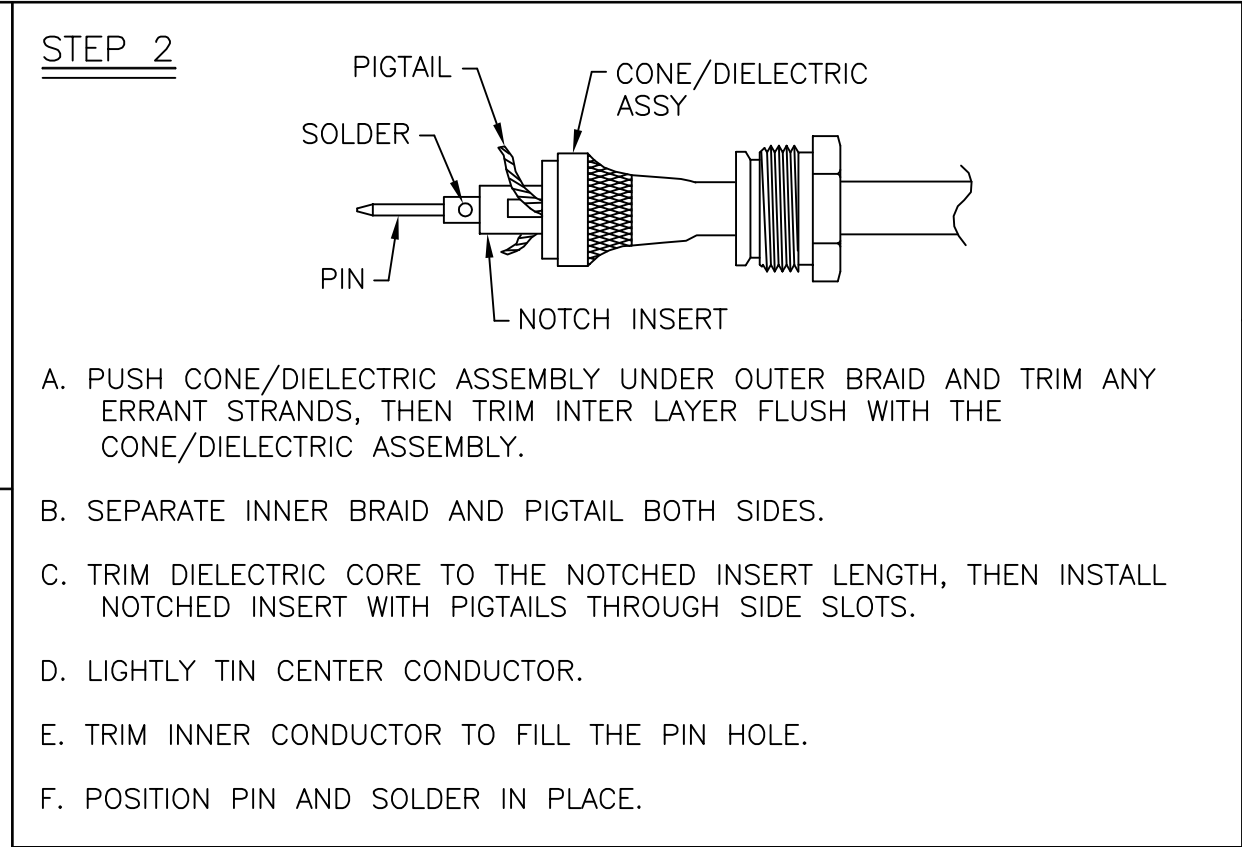
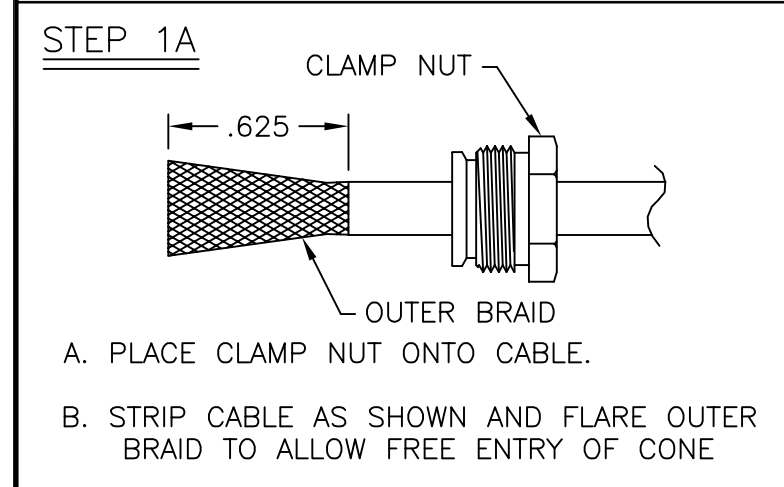

**ASSEMBLY INSTRUCTIONS**  
"70" SERIES WRENCH CRIMP TO M17/116-RG307



MGF. CODE NO. 14949  
TAI-250 REV A

MADE IN USA

UNLESS OTHERWISE SPECIFIED DIMENSIONS ARE IN INCHES TOLERANCES ARE:

FRACTIONS	DECIMALS	ANGLES
±	.XX ±	±
	.XXX ±	
	.XXXX ±	



SIGNATURES		DATE	"70" SERIES WRENCH CRIMP TO M17/116-RG307		
DRAWN BY C. WALLACE		11/16/10	SIZE <b>B</b>	CAGE CODE <b>14949</b>	DWG NO. TAI-250
CHECKED BY C. MONAHAN		11/17/10			
APPROVED BY C. MONAHAN		11/17/10	REV A		
APPROVED BY			SCALE N/A	DATE 11/16/10	SHEET 1 OF 2