

REV	ECO	DATE
G	52788	12/1/2010
H	55817	9/9/2015

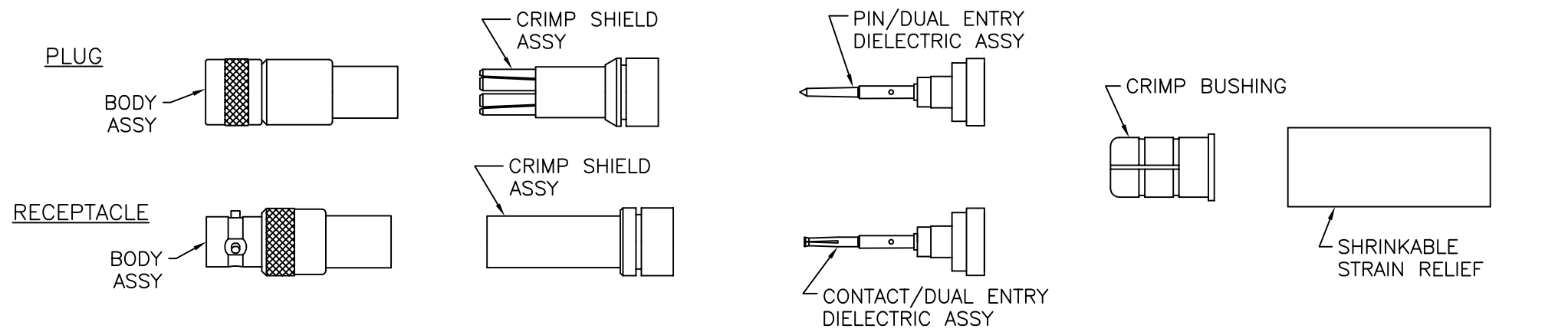

STEP 3

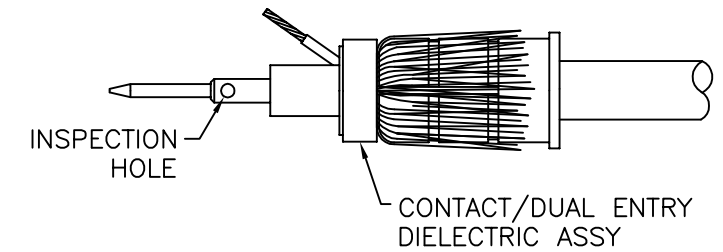

- BEND WHITE CONDUCTOR OUTWARD AND POSITION BLUE CONDUCTOR TO CENTER OF CABLE.
- INSTALL PIN/CONTACT/DUAL ENTRY DIELECTRIC ASSY OVER CONDUCTORS WITH BLUE CONDUCTOR THROUGH CENTER HOLE AND WHITE CONDUCTOR THROUGH SIDE SLOT AND SEAT AGAINST BRAID.
- CRIMP IN PLACE USING TEI LOCATOR 010-0041 WITH M22520/2-01 SETTING 4.

STEP 1

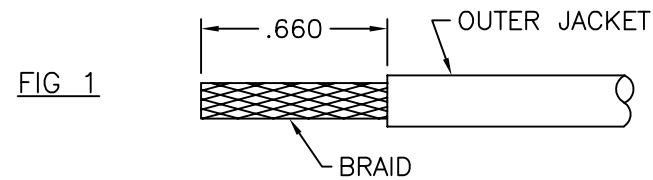

FIG 2

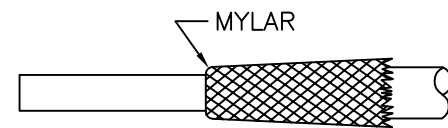
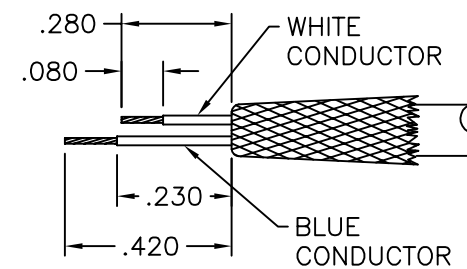

FIG 3



- REMOVE JACKET AS RECOMMENDED IN FIG 1, FOR -217 SEE FIG 2.
- COMB BRAID(S) BACK OVER JACKET (FIG 2).
- CUT CONDUCTORS AS SHOWN WITH RECOMMENDED DIMENSIONS (FIG 3), OPTIONAL; LIGHTLY TIN CONDUCTORS.

FOR -217, FOLD BACK OUTER BRAID AND REMOVE MYLAR, MU-METAL, ETC AS FAR BACK AS POSSIBLE

STEP 2

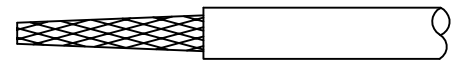

FIG A

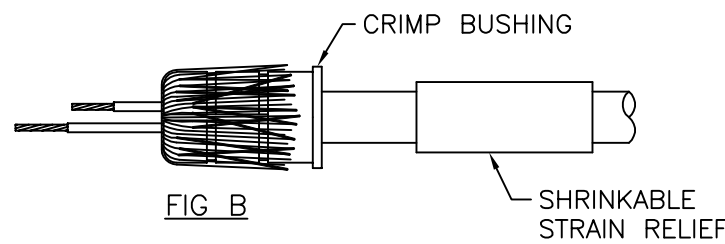
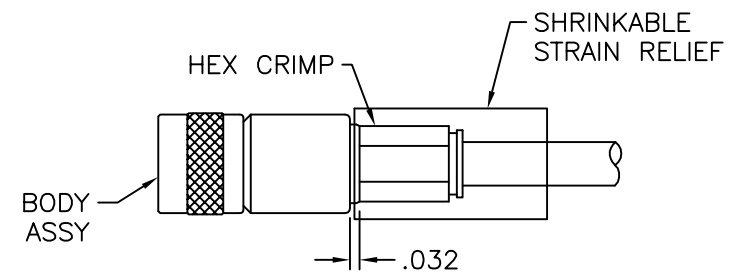

FIG B

- BRING BRAID(S) FORWARD OVER CONDUCTORS AND TWIST BRAID(S) AROUND CONDUCTORS (FIG A).
- PLACE SHRINKABLE STRAIN RELIEF ONTO CABLE.
- PUSH CABLE THRU CRIMP BUSHING UNTIL JACKET BOTTOMS INSIDE OF CRIMP BUSHING.
- FOLD BRAID(S) BACK OVER CRIMP BUSHING (FIG B).

STEP 5



- PUSH ENTIRE ASSEMBLY INTO BODY ASSEMBLY UNTIL BOTTOMED, HOLD ASSEMBLY FIRMLY BOTTOMED UNTIL FULLY HEX CRIMPED AS SHOWN USING MILITARY CRIMP TOOL M22520/5-01 WITH TEI DIE SET CD5-9, CLOSURE A, MAINTAIN .032 DIMENSION.
- BRING SHRINKABLE STRAIN RELIEF TO (APPROX) LOCATION SHOWN AND SHRINK IN PLACE.

STEP 4

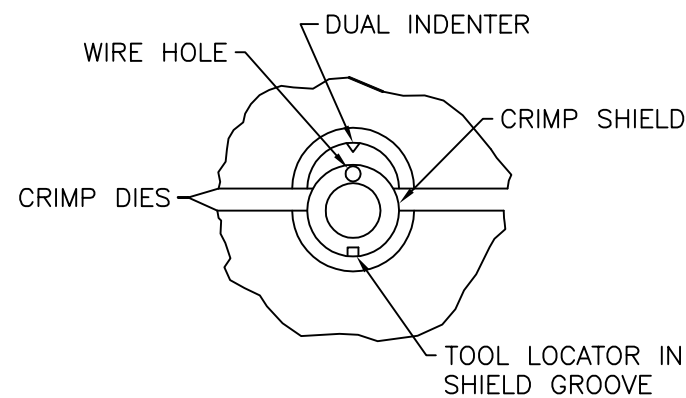
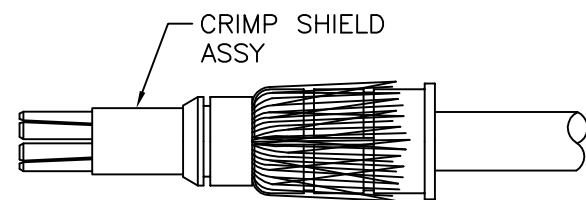

DETAIL A

- PLACE SHIELD/DIELECTRIC ASSY OVER CENTER CONTACT, PUT WHITE CONDUCTOR INTO SMALL HOLE AT REAR OF SHIELD/DIELECTRIC ASSY AND BOTTOM AGAINST DUAL ENTRY DIELECTRIC ASSY.
- CRIMP IN PLACE USING MILITARY CRIMP TOOL M22520/5-01 WITH TEI DIE SET CD5-9, CLOSURE B (SEE DETAIL A).

ASSEMBLY INSTRUCTIONS
"150AC" SERIES TO .160 DIA FLEXIBLE TWINAX CABLE



Cinch Connectivity Solutions
299 Johnson Avenue SW, Suite 100
Waseca, MN 56093 USA
T: +1 507.833.8822 F: +1 507.833.6287
cinch.com

MGF. CODE NO. 14949

TAI-143

REV H

<p>This PROPRIETARY Document is property of Cinch Connectivity Solutions. It is confidential in nature, non-transferable, and issued with the clear understanding that it is not to be reproduced, copied, or disseminated without permission and is returnable upon demand.</p> <p>INTERPRET DRAWING ACCORDANCE WITH ASME Y14.5-2009.</p>	Model No.	TAI-143	Title: TROMPETER	
	RoHS2	2011/65/EU	Cage Code	14949
	UNLESS OTHERWISE SPECIFIED UNITS: INCH	3RD ANGLE PROJECTION	Drawing No.	TAI-143
	DATE: 9/14/2015	SIZE: B	DO NOT SCALE DRAWING	1 OF 1