

THIS DRAWING AND THE SUBJECT MATTER SHOWN THEREON ARE CONFIDENTIAL AND THE PROPERTY OF BEL/STEWART/TRP CONNECTOR AND SHALL NOT BE REPRODUCED, COPIED, OR USED IN ANY MANNER WITHOUT THE WRITTEN CONSENT OF TRP CONNECTOR.

PRODUCT MAY BE PROTECTED BY ONE OR MORE OF THE FOLLOWING US PATENTS:
 5736910 5939955 6425781 6428361 6554638 6840817 7123117
 7429195 7717749 7808751 6217391 6149050 7924130

REVISIONS				
#	LTN	DESCRIPTION	DATE	DWN APVD
A	EC-1805032		23MAY2018	OL TY

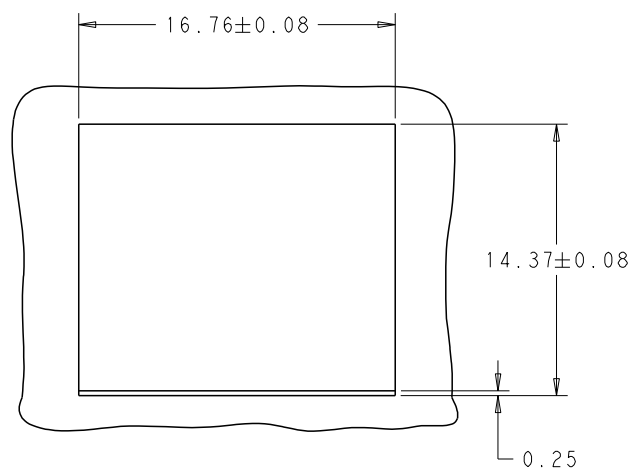
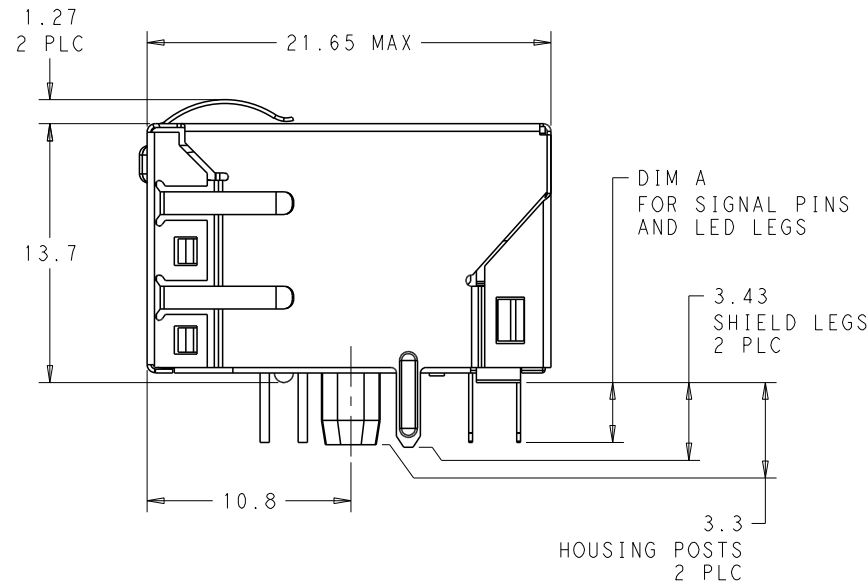
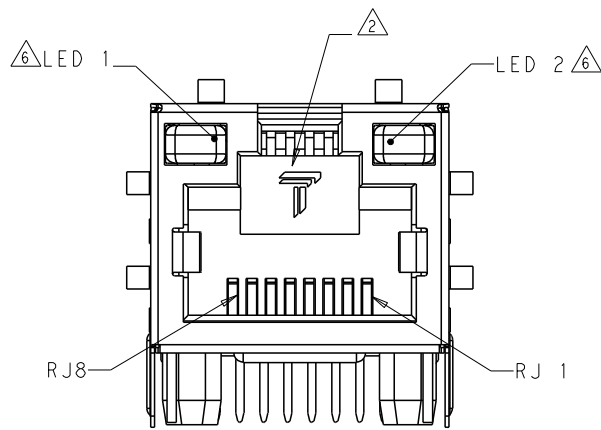
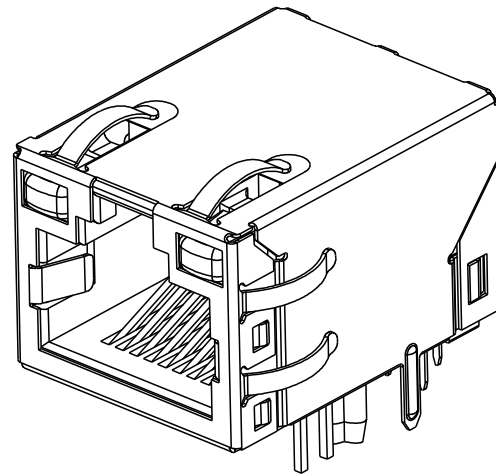
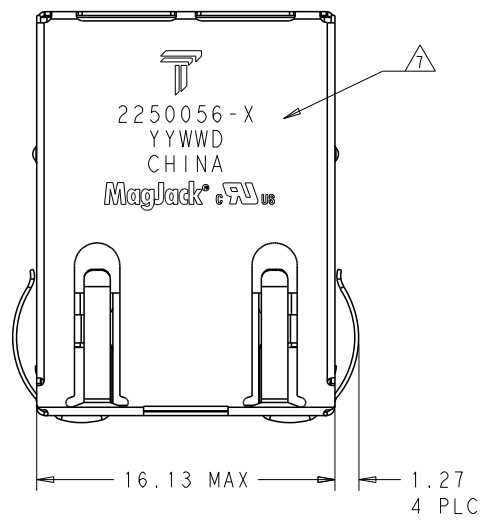

SUGGESTED CUT PANEL AND PCB

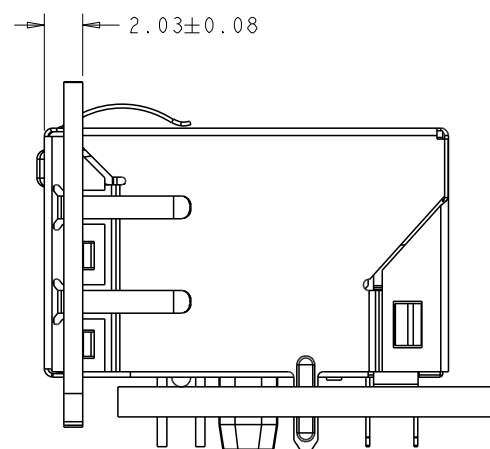

1. MATERIALS

- HOUSING: THERMOPLASTIC, FLAMMABILITY RATING UL 94V-0.
- SHIELD: BRASS 0.20mm THICK, PREPLATED WITH 0.76um MIN SEMI-BRIGHT NICKEL. SOLDER TABS POST DIPPED WITH 2.54um MIN SAC SOLDER.
- CONTACTS: PHOSPHOR BRONZE 0.46mm X 0.30mm, PHOSPHOR BRONZE, 1.27um MIN NICKEL UNDERPLATE, WITH 1.27um MIN GOLD PLATING AT MATING INTERFACE AND 2.54um MIN MATTE TIN ON SOLDER TAILS, OR 1.27um MIN NICKEL UNDERPLATE, WITH 0.05um GOLD PLATING OVER 0.76um MIN PALLADIUM NICKEL PLATING AT MATING INTERFACE AND 2.54um MIN MATTE TIN ON SOLDER TAILS.
- SOLDER TAILS: 0.25mm THICK, PHOSPHOR BRONZE, 1.27um MIN OVERALL NICKEL UNDERPLATE, 3um TIN PLATE
- LIGHT EMITTING DIODE (LED): DIFFUSED EPOXY LENS, 0.5mm X 0.5mm CARBON STEEL WIREFRAME LEADS PREPLATED WITH 2.03um MIN. SILVER PLATE OVER 1.02um MIN. NICKEL OVER 1.02um MIN. COPPER UNDERPLATE; LEADS POST-PLATED WITH 3.05um MIN. MATTE TIN AND/OR SAC SOLDER DIP OR PURE TIN SOLDER DIP

RJ45 JACK CAVITY CONFORMS TO FCC RULES AND REGULATIONS PART 68 SUB PART F.

MAGNETICS

- APPLICATION: 10/100 BASE-T, PoE, EXTENDED TEMPERATURE
- IMPEDANCE: 100 OHMS
- TURNS RATIO (CHIP:CABLE): TX = 1:1, RX = 1:1
- OPEN CIRCUIT INDUCTANCE (OCL): 350uH MIN @100kHz, 0.1VRMS, 8mADC BIAS FROM -40°C TO +85°C, TX AND RX
- POE CURRENT: 350mADC MAX
- PERFORMANCE @ 25°C:
 INSERTION LOSS (IL): 1.1dB MAX FROM 0.5MHz TO 100MHz
 RETURN LOSS (RL): 18dB MIN FROM 0.5MHz TO 30MHz
 18-20LOG(f/30)dB MIN FROM 30.1MHz TO 60MHz
 12dB MIN FROM 60.1MHz TO 80MHz
 CROSSTALK ATTENUATION: 35dB MIN FROM 0.5MHz TO 40MHz
 33-20LOG(f/50)dB MIN FROM 40.1MHz TO 100MHz
 COMMON MODE REJECTION RATIO (CMRR): 30dB MIN FROM 0.5MHz TO 100MHz
- ISOLATION VOLTAGE: 2250VDC FOR 60 SECONDS WITH A RISE TIME OF 500 V/SEC

4. OPERATING TEMPERATURE: FROM -40°C TO +85°C.

INDICATED MAGNETIC CONNECTIONS ARE SYMMETRICAL TO SUPPORT AUTO-MDI/MDIX.

LEDS WITH 250 OHM RESISTORS. LEDES ARE DRIVEN WITH 5V VOLTAGE AND THE MAX OPERATING CURRENT IS 20mA
 LED COLOR: DOMINATE WAVELENGTH (λD): GREEN 568 nm TYP. @ VF=5V
 FORWARD CURRENT (IF): GREEN 12mA TYP @ VF = 5V

TRP CONNECTOR LOGO, PART NUMBER, DATE CODE, COUNTRY OF ORIGIN AND AGENCY APPROVAL MARKING IN APPROXIMATE LOCATION SHOWN. DATE CODE: YYWW WHERE YY IS YEAR, WW IS WORK WEEK, D IS DAY OF WEEK, WITH SUNDAY=1.

PART SHOULD BE RECOMMENDED FOR WAVE SOLDERING PROCESS, PREHEAT TEMPERATURE IS 120°C TO 160°C, 120 SECONDS TO 180 SECONDS, PEAK WAVE SOLDERING TEMPERATURE IS 260°C MAX, 10 SECONDS MAX.

PART SHOULD BE RECOMMENDED FOR IR REFLOW SOLDERING PROCESS, PEAK SOLDERING TEMPERATURE IS 260°C MAX, DURATION TIME IS 10 SECONDS MAX, OVER 230°C WITHIN 40-60 SECONDS.

TAPE AND REEL	2.30	N/A		2250056-2
TRAY	3.68	GREEN	GREEN	2250056-1
SOLDERING PROCESS	PACKAGE METHOD	DIM A	11 → 12	13 → 14
			LED 1	LED 2
PART NUMBER				

THIS DRAWING IS A CONTROLLED DOCUMENT AND COMPLIANT TO ASME Y14.5M		DWN ROY LIU 06JUN2013	 DONGGUAN CHINA
DIMENSIONS: mm		CHK TOWER YU/FRANK LIU 06JUN2013	
TOLERANCES UNLESS OTHERWISE SPECIFIED:		APPD TONY YUAN 06JUN2013	 a bel group
0 PLC ±0.25	1 PLC ±0.25	MODEL NAME	DESC
2 PLC ±0.25	3 PLC ±0.25	MAGJACK	1X1 7U26ETL 10/100 POE
4 PLC ±	ANGLES ±	SINGLE PoE	TAB UP W/ LED
PRODUCT SPEC	APPLICATION SPEC	SIZE A1	RESTRICTED TO
		CAGE CODE	SCALE
		DRAWING NO	SHEET
		©=2250056	REV A
		CUSTOMER DRAWING	OF

Additional Resources: Product Page 3D Model Technical Documentation

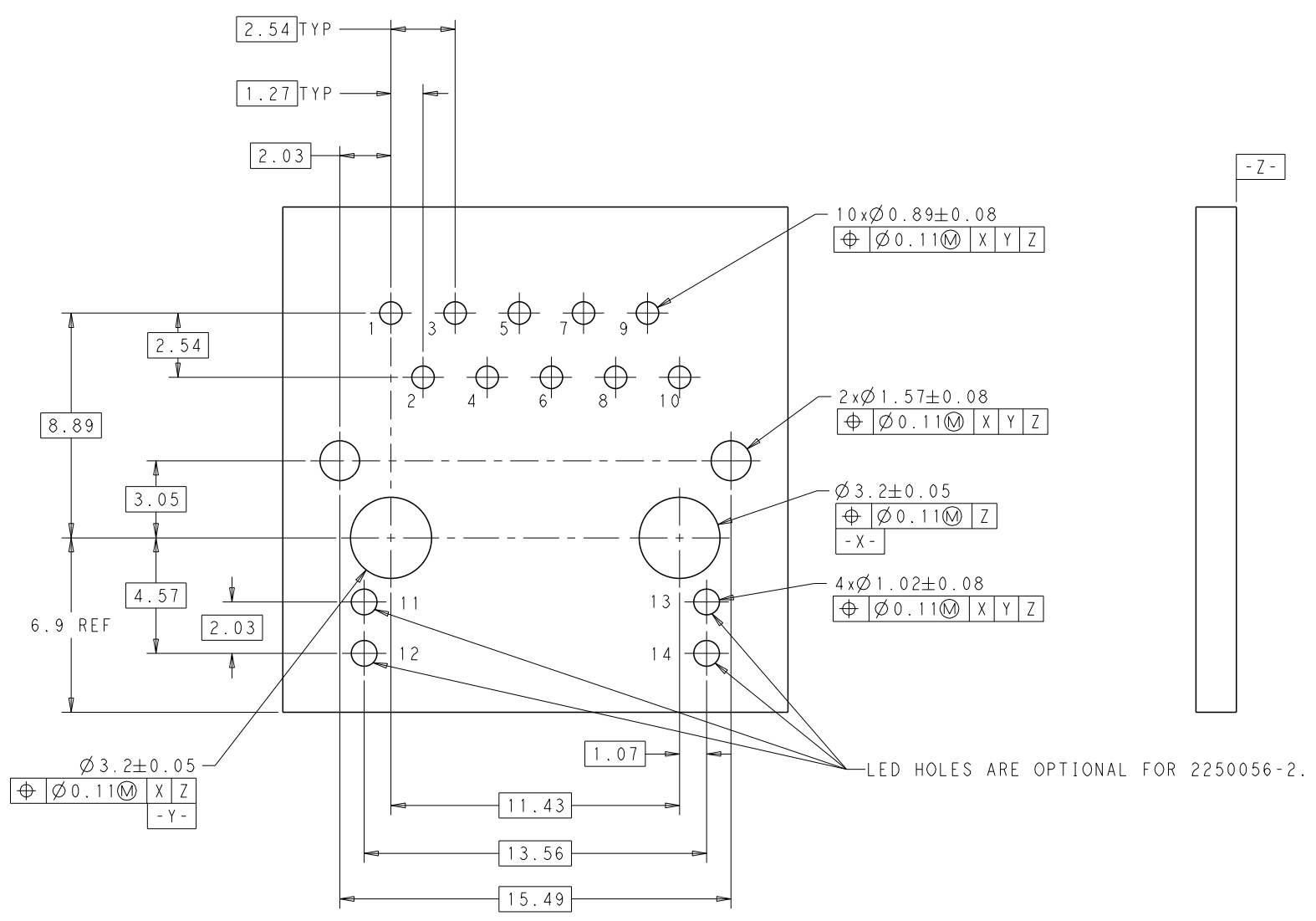

SUGGESTED CUSTOMER BOARD LAYOUT
(COMPONENT SIDE)

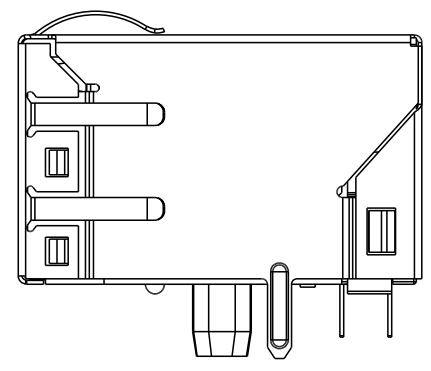

2250056-2 SHOWN
(WITHOUT LED)

Please read our datasheet & drawing disclaimer [here](#).

7U26ETL MAGNETIC CIRCUIT

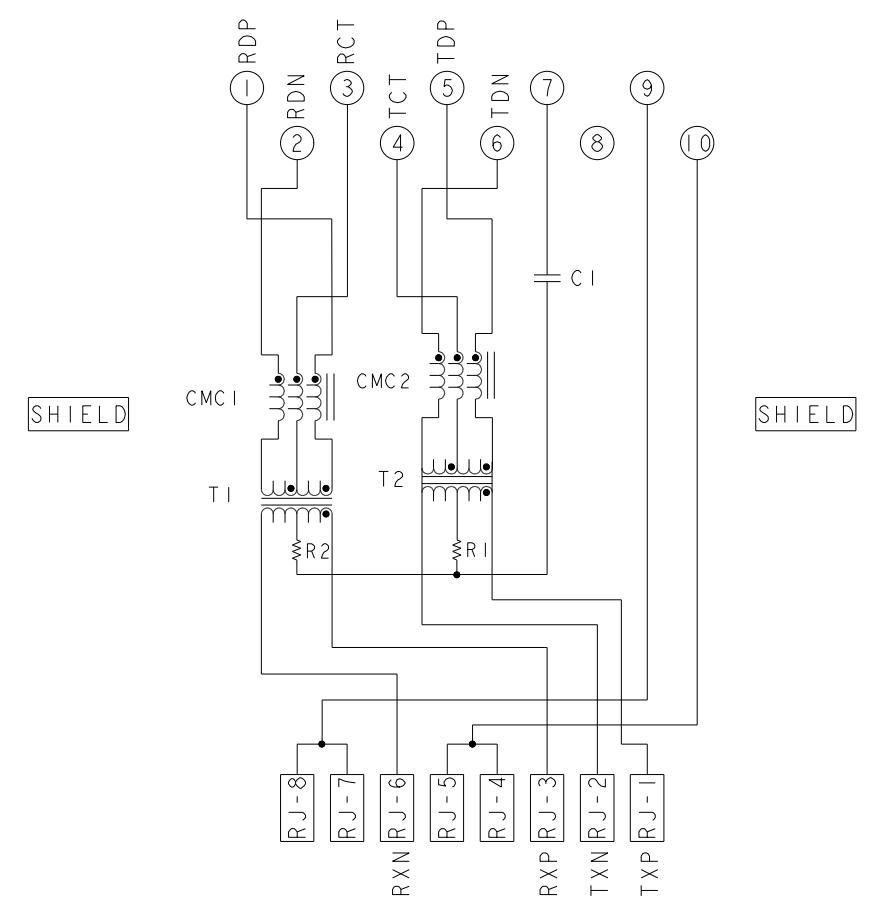

C1 = 1000 pF, 2kV CAPACITOR
R1-R2 = 75 OHMS, RESISTORS

THIS DRAWING IS A CONTROLLED DOCUMENT. AND COMPLIANT TO ASME Y14.5M		DWN ROY LIU 06JUN2013	 DONGGUAN CHINA
DIMENSIONS: mm		CHK TOWER YU/FRANK LIU 06JUN2013	
TOLERANCES UNLESS OTHERWISE SPECIFIED: 0 PLC ±0.25 1 PLC ±0.25 2 PLC ±0.25 3 PLC ±0.25 4 PLC ± ANGLES ±°		APP'D TONY YUAN 06JUN2013	
PRODUCT SPEC	APPLICATION SPEC	MODEL NAME MAGJACK SINGLE PoE	DESC 1X1 7U26ETL 10/100 POE TAB UP W/ LED
		SIZE A1	RESTRICTED TO
		CAGE CODE 2250056	SCALE
		SHEET	