

Powerline Modules

Green PHY Module

The module is a HomePlug Green PHY Powerline Communications (PLC) transceiver/modem.

Provides an integrated Powerline communications solution for microcontroller based embedded system.

Communication is possible over any 2 wire system AC, DC or Dry wire.

Key Features & Benefits

- Based on Qualcomm Atheros QCA7000 chip
- Compliant HomePlug Green PHY 1.1 specification
- Fully interoperable with HomePlug AV and IEEE 1901 compliant products
- Host interface type depend on the module variant: UART, SPI or UART-AT
- Supports OFDM (ROBO) mode modulation, with PHY data rates up to 10Mbps
- 128-bit AES Link Encryption with key management for secure power line communications
- Integrates core components necessary to add powerline communication functionality to any embedded system at low cost
- Supports large 32 node unicast networks - up to 254 broadcast mode devices per AVLN with up to 16 overlapping AVLNs
- Commercial temperature range (Industrial option available upon request)
- Powered from single 3.3 VDC rail
- Ideal for Smart Grid applications



Models

Part Number	Temp Range	Interface	Market
0804-5000AG0	0°C – +70°C	UART-AT	Worldwide
0804-5000AG1	0°C – +70°C	SPI	Worldwide
0804-5000AG2	0°C – +70°C	UART	Worldwide

Powerline Modules

Green PHY Module

Block Diagram

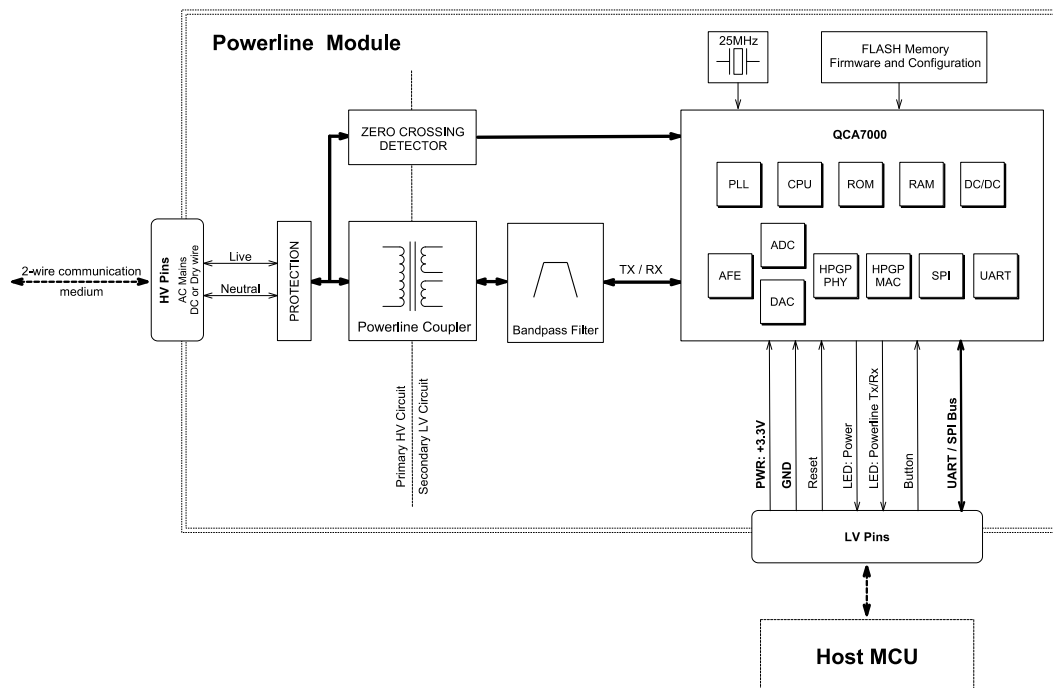

Module pinouts

Module connectivity is provided via J1, J2 and J3 gold pin headers.

J1 - 8 way 2.54mm pitch gold pin header

Pin Number	Pin Name	Type	Description
1	VDD	PWR	+3.3V
2	VDD	PWR	+3.3V
3	VSS	PWR	Ground
4	RESET#	I	Resets powerline IC when low
5	RESERVED ^[1]	PWR	Reserved pin
6	GPIO0	I/O	Strap0; Push-button
7	GPIO1	I/O	Strap1
8	GPIO2	I/O	Strap2; LED: Powerline Tx/Rx Link

[1] Leave reserved pin disconnected

Powerline Modules

Green PHY Module

J2 - 8 way 2.54mm pitch gold pin header

Pin Number	Pin Name	Type	Description
1	VSS	PWR	Ground
2	GPIO3	I/O	Strap3; LED: Power
3	GPIO4	I/O	UART: - / SPI: INTR
4	GPIO5	I/O	UART: RTS ^[1] / SPI: CLK
5	GPIO6	I/O	UART: CTS ^[1] / SPI: CS
6	GPIO7	I/O	UART: TX / SPI: DO
7	GPIO8	I/O	UART: RX / SPI: DI
8	VSS	PWR	Ground

J3 - 2 way 7.62mm pitch gold pin header

Pin Number	Pin Name	Type	Description
1	AC_NEUTRAL	PL	Powerline communication medium ^[2]
2	AC_LINE	PL	Powerline communication medium ^[2]

[2] Voltage rating: 250VAC (50/60Hz)

Strap Configuration

The Powerline chipset boot options are selected by the initial condition of GPIO pins. If a GPIO pin is not used but the internal strapping resistor sets the booting option incorrectly, then the pin must be pulled high or low to the correct booting option by an external resistor. This resistor can be 10k-Ohms down to 3.3k-Ohms. Connecting GPIO directly to ground or VDD is not permitted.

Strap	Internal Pull Up/Down	Description	Typical Configuration
Strap0	Pull Up	Pull Up - Load firmware from flash device	Pull Up
Strap1	Pull Up	Must be pulled-down	Pull Down
Strap2	Pull Down	Pull Up - Burst command/data	Pull Up
Strap3	Pull Down	Must be pulled-down	Pull Down

Powerline Modules

Green PHY Module

LED and Push-button Strapping

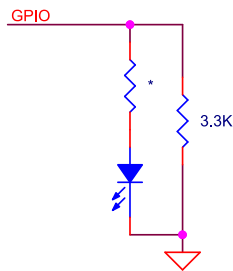

Figure 1 LED Strapping for GPIO Pull-down

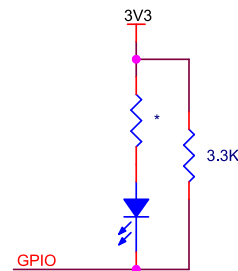

Figure 2 LED Strapping for GPIO Pull-up

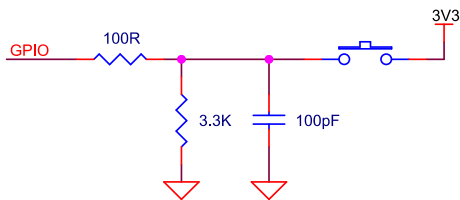

Figure 3 Push-button Strapping for GPIO Pull-down

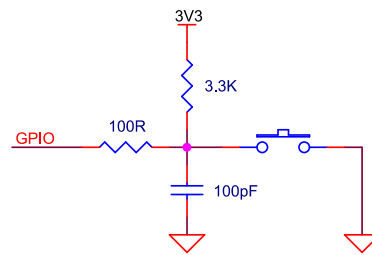

Figure 4 Push-button Strapping for GPIO Pull-up

General Specifications

Symbol	Parameter	Test Conditions	Min	Max	Units
VDD	Supply voltage ^[1]		3.13	3.45	V
VIL	Low-level input voltage			0.8	V
VIH	High-level input voltage		2.0		V
VOL	Low-level output voltage	IOL = 4 mA, 12 mA ^[2]		0.4	V
VOH	High-level output voltage	IOH = -4 mA, -12 mA ^[3]	2.4		V
IIL	Low-level input current	VI = Gnd	-1		μA
IIH	High-level input current	VI = 3.3 V		1	μA
IOZ	High-impedance output current	Gnd < VI < 3.3 V	-1	+1	μA
Top	Operating temperature range ^[4]		0 -40	+70 +85	°C

[1] A typical supply current, assuming a nominal operation of 50% transmit and 50% receive duty cycle, is 200 mA.

[2] IOL=12 mA for all GPIOs. IOL = 4 mA for all other digital interfaces.

[3] IOH = -12 mA for all GPIOs. IOH = -4 mA for all other digital interfaces.

[4] Standard module is available in commercial temperature range (industrial is an option)

Power supply should be capable to provide from 1.3 to 1.6 Watts. These power levels provide a higher power margin than required in normal operation.

Powerline Modules

Green PHY Module

Dimensions

Width: 30.9mm, Length: 44.3mm, Height: 14.3mm

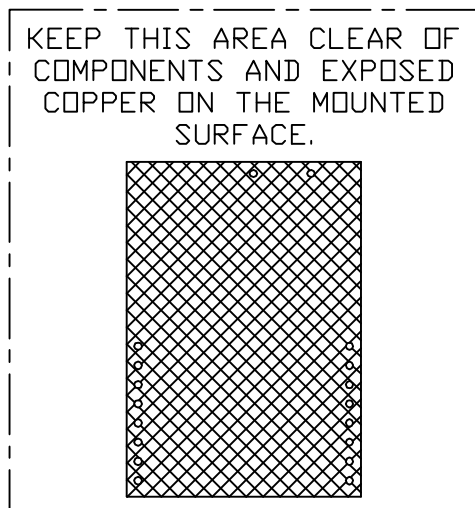
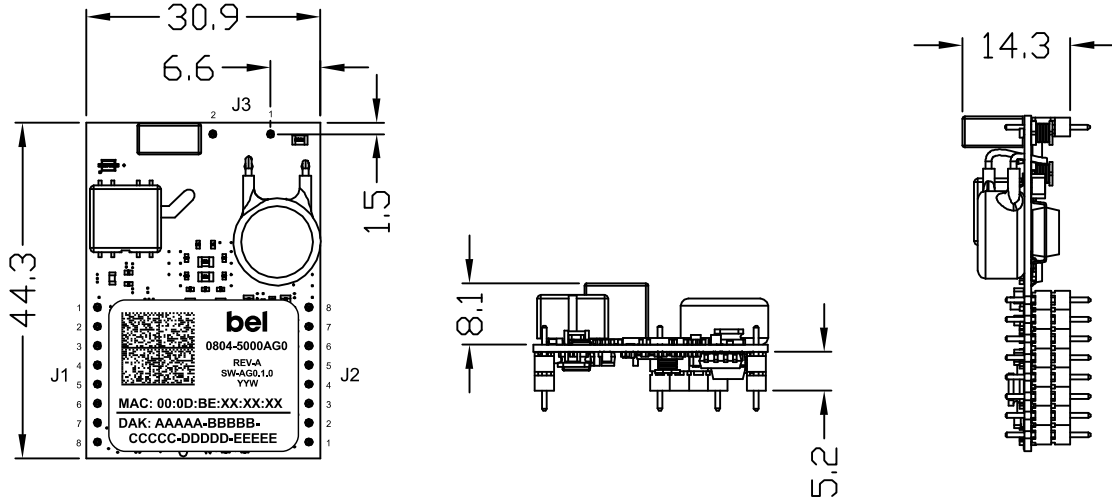

RECOMMENDED PCB LAYOUT

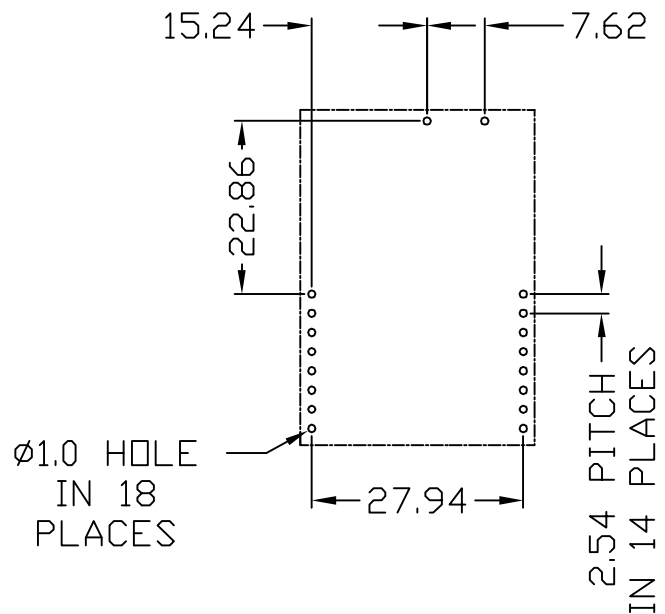

All specifications subject to change without notice.