

Features

- 15W isolated output
- Efficiency to 82%
- 4:1 input range
- Six sided shield
- Remote On/Off Control



Model Number	Input Voltage	Output Voltage	Output Current	Input Current		Effic.	Case
				No Load	Full Load		
VCQ15-Q24-S5-T	9-36VDC	5VDC	3000mA	15mA	810mA	77%	C
VCQ15-Q24-S12-T	9-36VDC	12VDC	1250mA	15mA	780mA	80%	C
VCQ15-Q24-S15-T	9-36VDC	15VDC	1000mA	15mA	780mA	80%	C
VCQ15-Q24-D5-T	9-36VDC	±5VDC	±1500mA	20mA	0810mA	77%	C
VCQ15-Q24-D12-T	9-36VDC	±12VDC	±625mA	20mA	780mA	80%	C
VCQ15-Q24-D15-T	9-36VDC	±15VDC	±500mA	20mA	780mA	80%	C
VCQ15-Q24-S3R3-T	9-36VDC	3.3VDC	3000mA	15mA	545mA	76%	C
VCQ15-Q48-S5-T	18-72VDC	5VDC	3000mA	10mA	410mA	77%	C
VCQ15-Q48-S12-T	18-72VDC	12VDC	1250mA	10mA	390mA	80%	C
VCQ15-Q48-S15-T	18-72VDC	15VDC	1000mA	10mA	390mA	80%	C
VCQ15-Q48-D5-T	18-72VDC	±5VDC	±1500mA	15mA	400mA	79%	C
VCQ15-Q48-D12-T	18-72VDC	±12VDC	±625mA	15mA	380mA	82%	C
VCQ15-Q48-D15-T	18-72VDC	±15VDC	±500mA	15mA	380mA	82%	C
VCQ15-Q48-S3R3-T	18-72VDC	3.3VDC	3000mA	10mA	270mA	76%	C

Input

Input Voltage Range	24V: 9-36V 48V: 18-72V
Input Filter	Pi Type

Output

Voltage Accuracy	Single Output	±1.0% max.
	Dual +Output	±1.0% max.
	-Output	±3.0% max.
	Triple, 5V	±2.0% max.
	12V/15V	±3.0% max.
Voltage Balance (Dual)		±1.0% max
Transient Response:	Single, 25% Step Load Change	<500µ sec.
	Dual, FL-1/2±1% Error Band	<500µ sec.
External Trim Adj. Range		±10%
Ripple & Noise	20MHz BW	10mV RMS., max 75mV p-p, max
Temperature Coefficient		±0.02%/°C
Short Circuit Protection		Continuous
Line Regulation ¹	Single/Dual	±0.2% max.
	Triple	±1.0% max.
Load Regulation ²	Single/Dual	±1.0% max.
	Triple	±5.0% max.

General Specifications

Efficiency	see table
Isolation Voltage	500VDC min.
Isolation Resistance	10 ⁹ Ohm min.
Switching Frequency	300KHz, Type
Case Grounding	Connected to Output common
Operating Temperature Range	-25°C to +71°C
Case Temperature	100°C max.
Cooling	Free-Air Convection
Storage Temperature	-55°C to +105°C
EMI/RFI	Six Sided Continuous Shield
Dimensions	2x2x0.4 inches (50.8x50.8x10.2mm)
Case Material	Black coated copper with non-conductive base

NOTES:

1. Measured from High Line to Low Line
2. Measured from Full Load to 1/4 Load

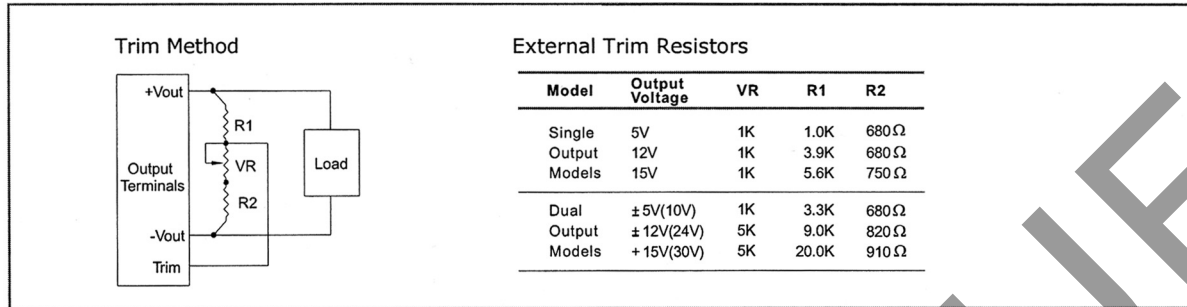

Single Output

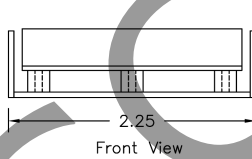
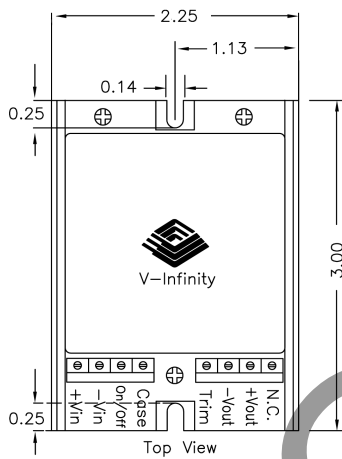

Dual Output

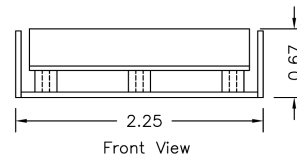
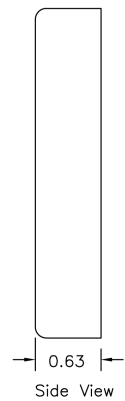
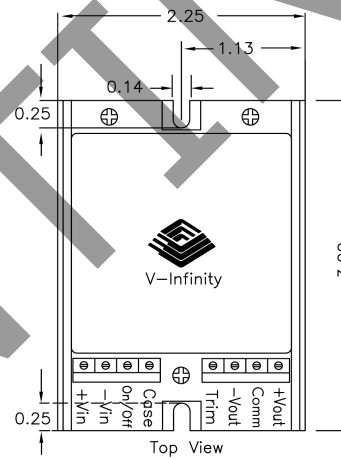

PIN Definitions

+Vin:	Input positive terminal
-Vin:	Input negative terminal
CNT:	Remote On/Off control of output voltage. Referenced to -Vin
+Vout:	Main output positive terminal
-Vout:	Output negative terminal
Com:	Common node for dual- or triple-output models
Trim:	For trimming output voltage on single- or dual-output models
Case:	Connected to chassis

REV.	DESCRIPTION	DATE
A	NEW DRAWING	10/13/2006

Optional DIN Rail Mounting Bracket

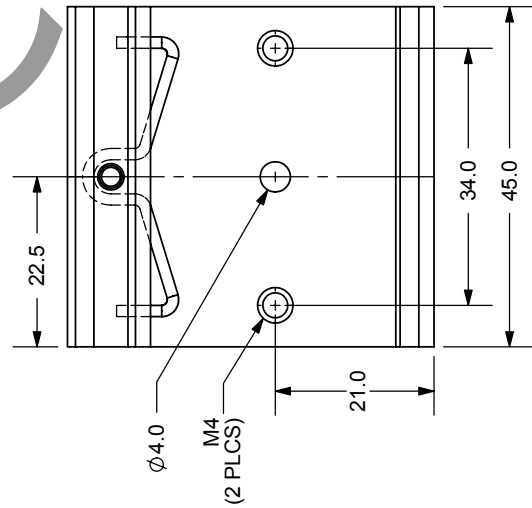
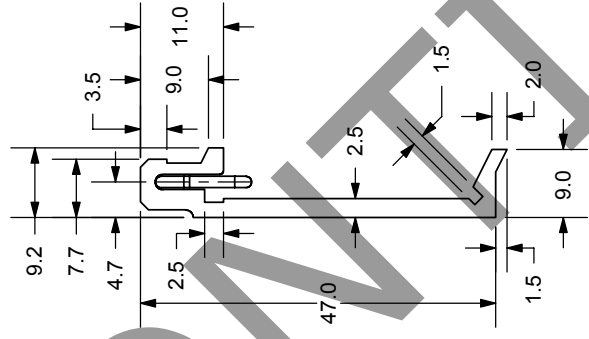
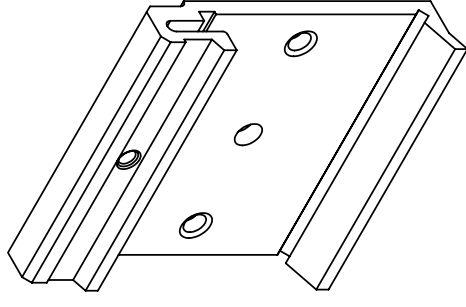

20050 SW 112th Ave.
Tualatin, OR 97062
Phone: 503-643-4899
800-275-4899
Fax: 503-372-1266
Website: www.v-infinity.com

TITLE:	DIN RAIL MOUNTING BRACKET	REV:	A
PART NO:	VDRP-03	UNITS:	MM [INCHES]
DRAWN BY:	ZRJ	APPROVED BY:	
		SCALE:	1:1

PC FILE NAME: VDRP-03

COPYRIGHT 2006 BY CUI INC.