

THE INFORMATION CONTAINED HEREIN IS CONSIDERED "PROPRIETARY" TO BEL FUSE INC. AND SHALL NOT BE COPIED, REPRODUCED OR DISCLOSED WITHOUT THE WRITTEN APPROVAL OF BEL FUSE INC.

PRELIMINARY

SCHEMATIC

RoHS  
2002/95/EC



ELECTRICAL CHARACTERISTICS @ 25°C

URNS RATIO

TX 1CT : 1  
RX 1CT : 1

CL @ 100kHz/100mVRMS

8mA DC BIAS (0-70°C) 350µH MIN.

INS. LOSS

0.1MHz TO 1MHz -1.1 dB MAX  
1MHz TO 65MHz -0.5 dB MAX  
65MHz TO 100MHz -0.8 dB MAX  
100MHz TO 125MHz -1.2 dB MAX

RET. LOSS (MIN)

@ 100 OHMS +/- 15%  
0.5MHz-40MHz -18 dB  
40MHz-100MHz -12+20LOG(f/80MHz) dB

CM TO CM REJ

100kHz - 100MHz -30 dB MIN

CM TO DM REJ

100kHz - 100MHz -35 dB MIN

HIPOT (Isolation Voltage):

1500 Vrms

100% OF PRODUCTION TESTED TO COMPLY WITH IEEE 802.3 ISOLATION REQUIREMENTS.

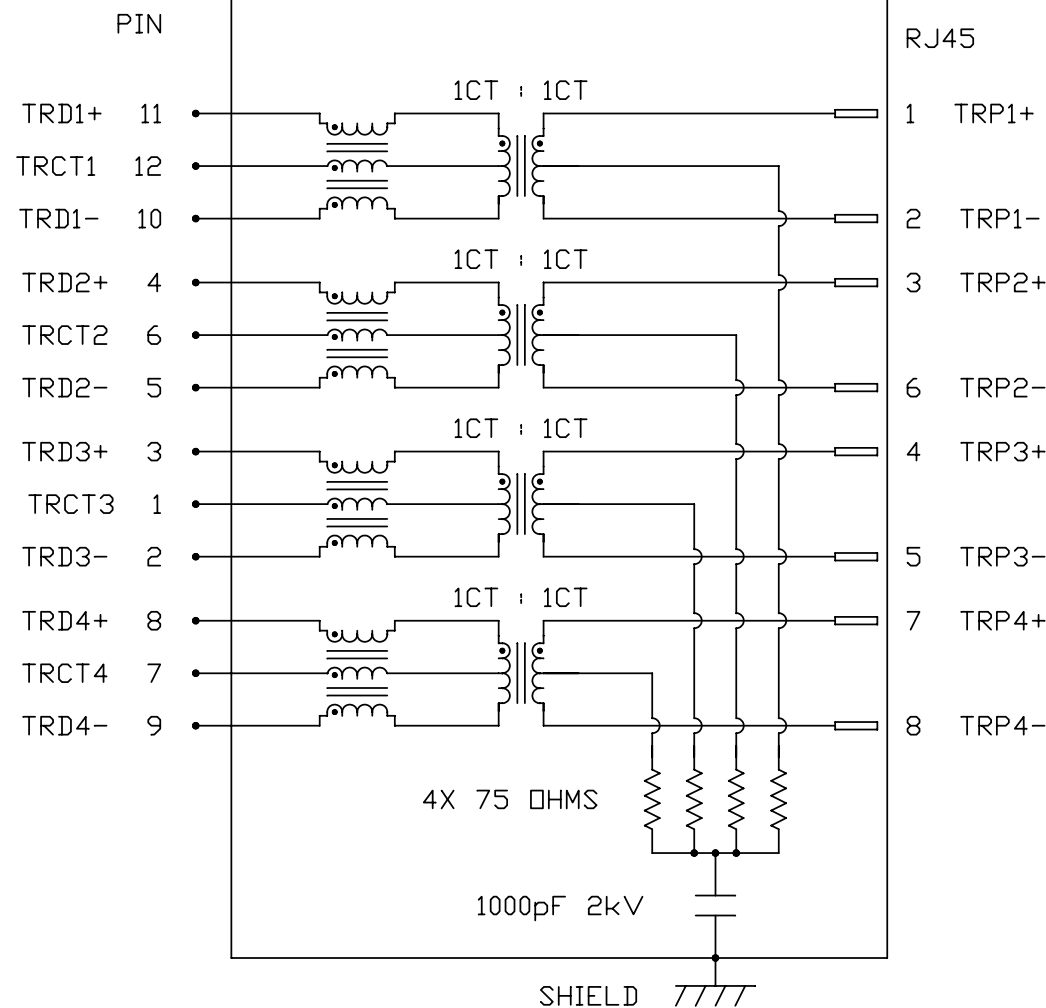

ORIGINATED BY	DATE
CHOW WANCHUNG	2012-01-18
DRAWN BY	DATE
LEE WEIDE	2012-01-18

TITLE	gigabit MagJack® (NanoJack) PATENTED
PART NO. / DRAWING NO.	
FILE NAME	L835-1XX1-S7
	L835-1XX1-S7_PB.DWG

STANDARD DIM. TOL. IN INCH	[ ] METRIC DIM. AS REFERENCE
.X	UNIT : INCH [mm]
.XX	REV. : PB
.XXX	SCALE : N/A
	SIZE : A4
	PAGE : 2

UNIT : INCH [mm]	REV. : PB
SCALE : N/A	SIZE : A4
	PAGE : 2



THE INFORMATION CONTAINED HEREIN IS CONSIDERED "PROPRIETARY" TO BEL FUSE INC. AND SHALL NOT BE COPIED, REPRODUCED OR DISCLOSED WITHOUT THE WRITTEN APPROVAL OF BEL FUSE INC.

RoHS  
2002/95/EC



PRELIMINARY

MECHANICAL SPECIFICATION

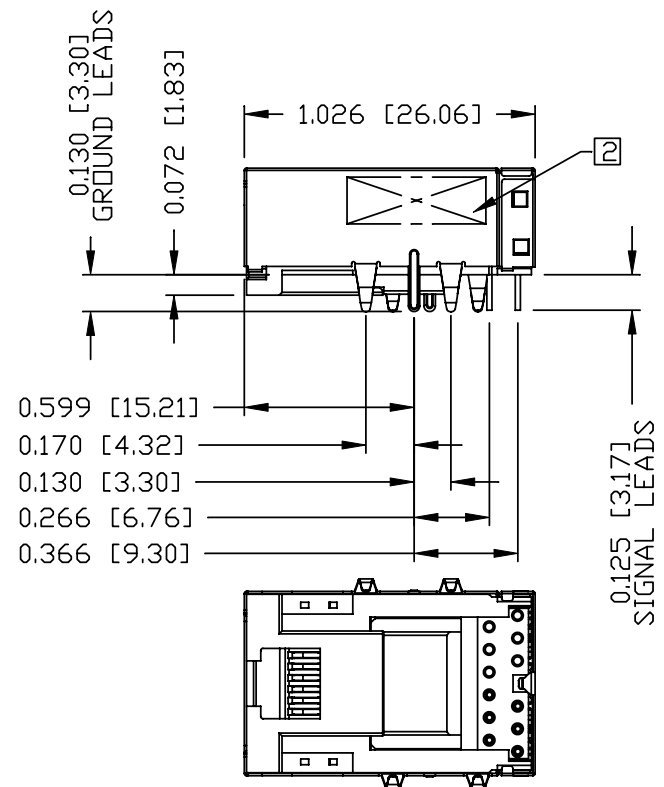
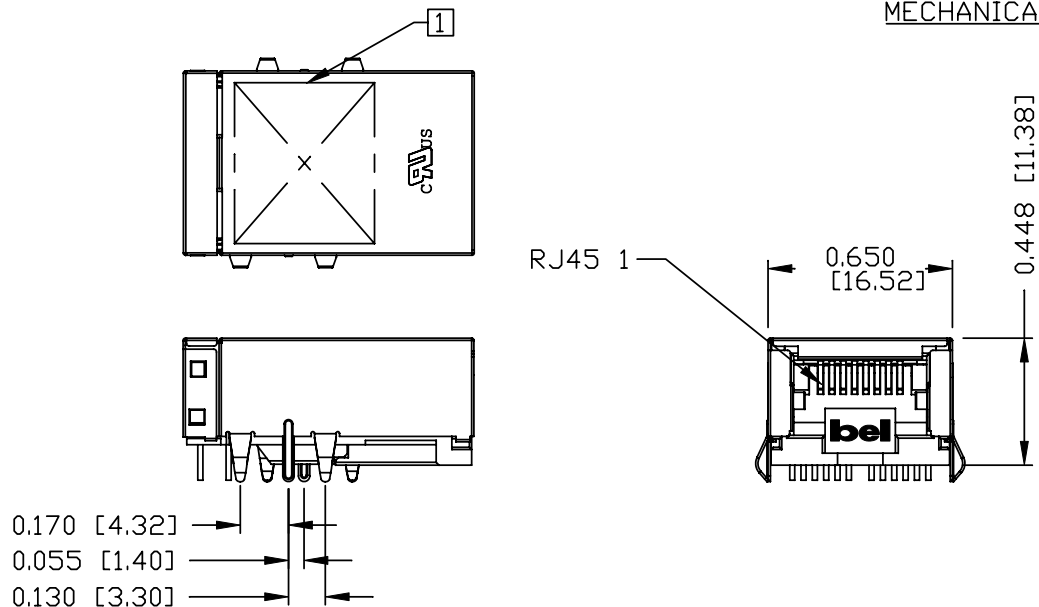

NOTES:

- PLASTIC HOUSING: THERMOPLASTIC PBT  
FLAMMABILITY RATING UL 94V-0
- CONTACTS: 30 MICRO-INCH HARD GOLD PLATING OR EQUIVALENT
- OUTPUT PINS: TIN-COATED COPPER WIRE, DIA 0.018 INCH.
- METAL SHIELD: NICKEL PLATED ON COPPER ALLOY.  
(ALL GROUND LEADS ARE SOLDER DIPPED)
- JACK CAVITY CONFORMS TO FCC RULES AND REGULATIONS, PART 68 SUBPART F.
- 1. MARK PART WITH MFG. LOGO, MFG. NAME, PART NUMBER, AND DATE CODE.
- 2. MARK PART WITH PATENTED.
- 3. THE PRODUCT IS RoHS COMPLIANT.

- 4. THE PRODUCT IS PATENT PRODUCT. THE PATENT NUMBER ARE U.S. PAT. 6,840,817 AND U.S. PAT. 5,736,910 AND U.S. PAT. 7,123,117.

USUL RECOGNIZED - FILE #E196366 AND E169987.

ORIGINATED BY ANTON LIAO	DATE 2012-01-18	TITLE gigabit MagJack® (NanoJack) PATENTED	PART NO. / DRAWING NO. L835-1XX1-S7		STANDARD DIM. TOL. IN INCH		[ ] METRIC DIM. AS REFERENCE	
			FILE NAME L835-1XX1-S7_PB.DWG		.X		UNIT : INCH [mm]	REV. : PB
DRAWN BY WU ZHIHENG	DATE 2012-01-18				.XX		SCALE : N/A	SIZE : A4
					.XXX	±0.010		PAGE : 3



THE INFORMATION CONTAINED HEREIN IS CONSIDERED "PROPRIETARY" TO BEL FUSE INC. AND SHALL NOT BE COPIED, REPRODUCED OR DISCLOSED WITHOUT THE WRITTEN APPROVAL OF BEL FUSE INC.

RoHS  
2002/95/EC



PRELIMINARY

RECOMMENDED PCB FOOTPRINT  
COMPONENT SIDE VIEW

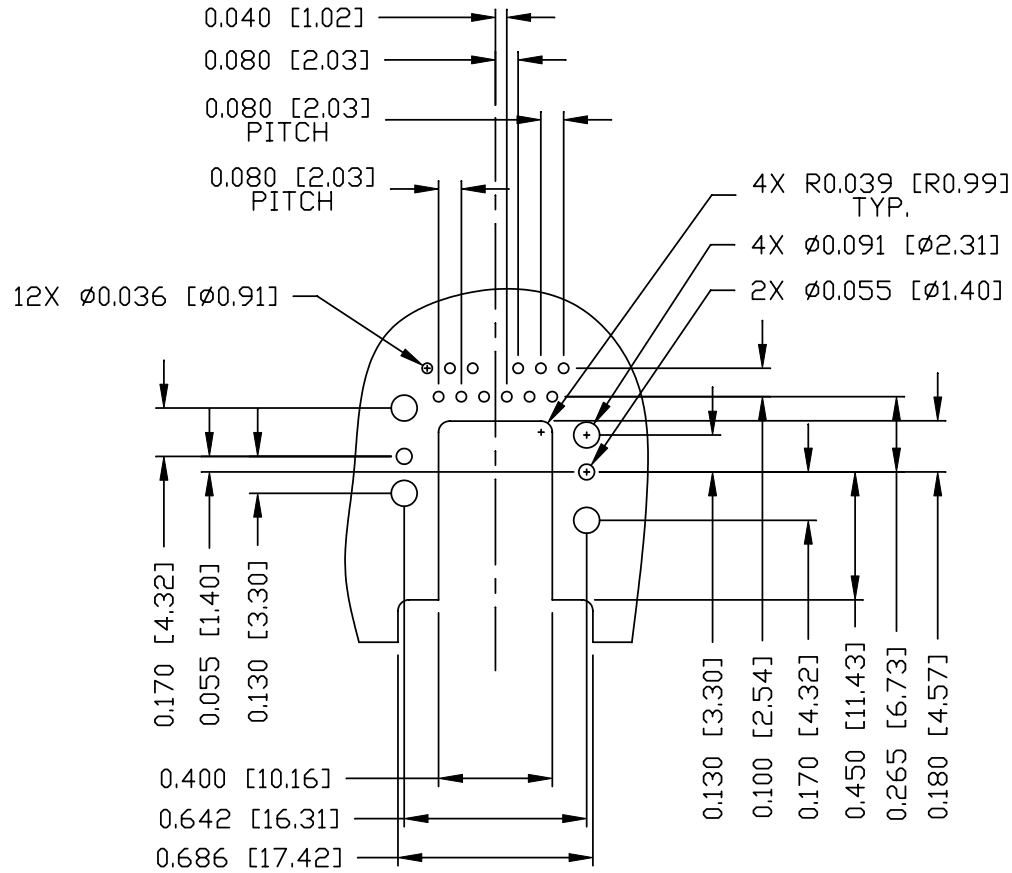

FOR ONE UNIT

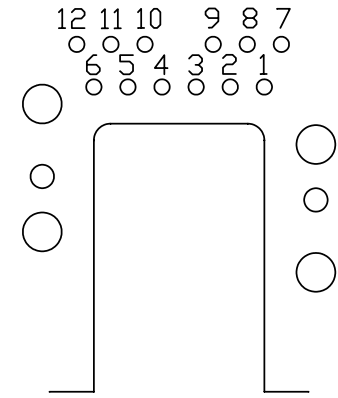

PIN-OUT ASSIGNMENT  
(SCALE 1.5:1)

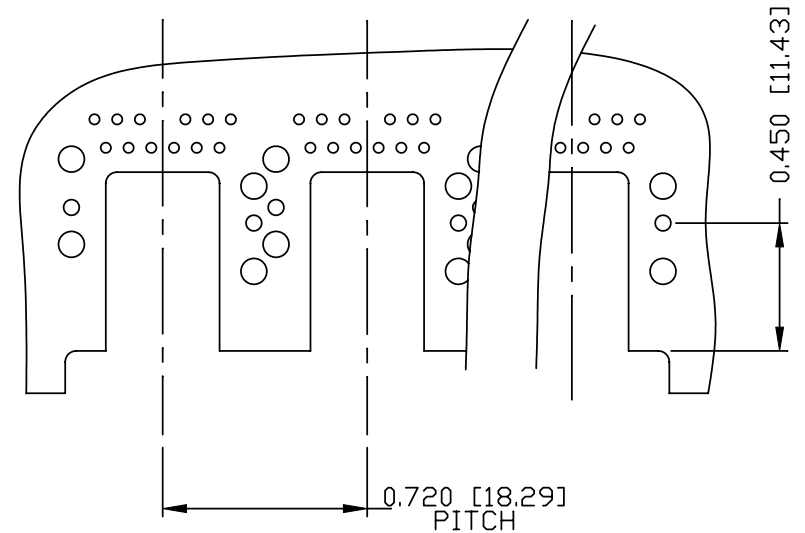

FOR MULTI-UNITS

ORIGINATED BY ANTON LIAO	DATE 2012-01-18	TITLE gigabit MagJack® (NanoJack) PATENTED	PART NO. / DRAWING NO. L835-1XX1-S7		STANDARD DIM. TOL. IN INCH		[ ] METRIC DIM. AS REFERENCE		 COMPONENTS FOR A CONNECTED PLANET
	DRAWN BY WU ZHIHENG		DATE 2012-01-18	FILE NAME L835-1XX1-S7_PB.DWG	.X	 ±0.004	UNIT : INCH [mm]	REV. : PB	
			.XX	SCALE : N/A	SIZE : A4				
			.XXX	 ±0.004	PAGE : 4				

THE INFORMATION CONTAINED HEREIN IS CONSIDERED 'PROPRIETARY' TO BEL FUSE INC. AND SHALL NOT BE COPIED, REPRODUCED OR DISCLOSED WITHOUT THE WRITTEN APPROVAL OF BEL FUSE INC.

PRELIMINARY

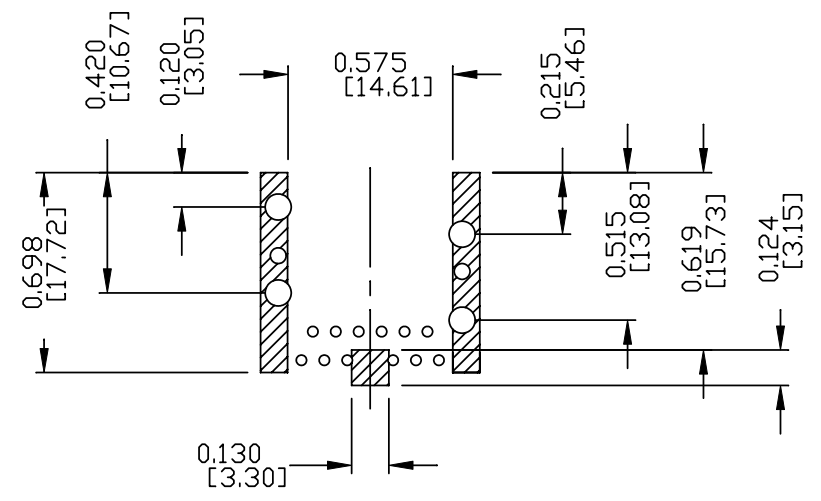
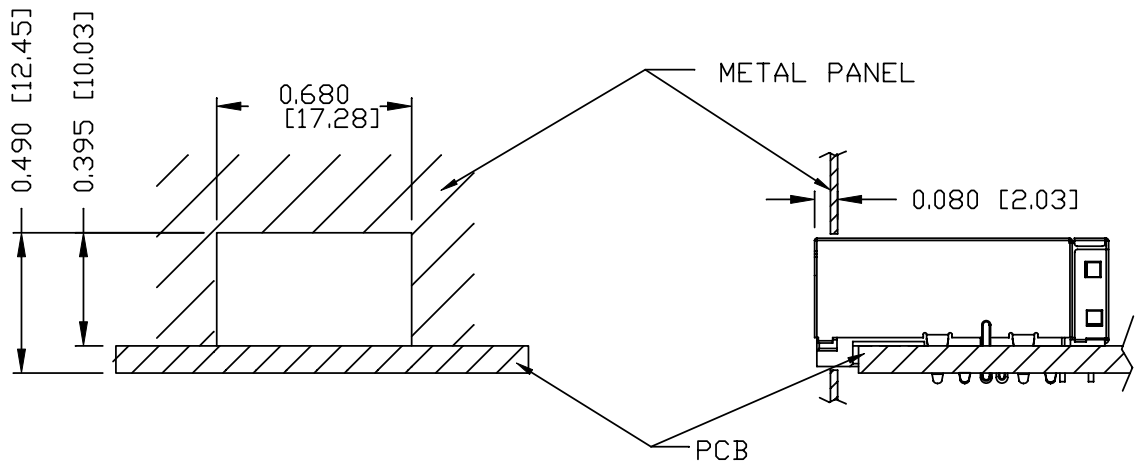

**NOTE:**

THE DISTANCE OF PANEL INSIDE SURFACE RELATIVE TO FRONT SURFACE OF PART IS ONLY A SUGGESTION. IN CASE THIS DISTANCE IS DIFFERENT, THE REQUIRED PANEL OPENING DIMENSIONS CHANGE ACCORDINGLY.

**TRAY PACKING INFORMATION**

PACKING TRAY : 0200-9999-M3(TOP)  
0200-9999-M4(BOTTOM)

PACKING QUANTITY : 65 PCS FINISHED GOODS PER TRAY,  
12 TRAYS (780 PCS FINISHED GOODS) PER CARTON BOX.

NOTE : CARDBOARDS ARE PLACED BETWEEN LAYERS OF PACKING TRAY INSIDE CARTON BOX (INCLUDE THE UPPERMOST AND LOWERMOST TRAY)

THE SHADED AREA ON THE CUSTOMER BOARD ARE RECOMMENDED TO BE CLEAR OFF ANY VIA HOLE OR COMPONENT PAD.

ORIGINATED BY ANTON LIAO	DATE 2012-01-18	TITLE gigabit MagJack® (NanoJack) PATENTED	PART NO. / DRAWING NO. L835-1XX1-S7	STANDARD DIM. TOL. IN INCH		[ ] METRIC DIM. AS REFERENCE		bel COMPONENTS FOR A CONNECTED PLANET
	DRAWN BY WU ZHIHENG			DATE 2012-01-18	FILE NAME L835-1XX1-S7_PB.DWG	.X .XX .XXX	±0.004	