

THE INFORMATION CONTAINED HEREIN IS CONSIDERED "PROPRIETARY" TO BEL FUSE INC. AND SHALL NOT BE COPIED, REPRODUCED OR DISCLOSED WITHOUT THE WRITTEN APPROVAL OF BEL FUSE INC.

PRELIMINARY



LED 2 & 4 POLARITY			LED 1 & 3 POLARITY		
PIN 11	PIN 12	COLOR	PIN 13	PIN 14	COLOR
+	-	GREEN	+	-	GREEN

ELECTRICAL CHARACTERISTICS @ 25°C

URNS RATIO

TP1 1CT : 1CT ±2%
 TP2 1CT : 1CT ±2%

OCL @ 100kHz/100mVRMS 350µH MIN.

8mA DC BIAS (0°C - 70°C)

INS. LOSS

0.1MHz TO 1MHz -1.1 dB MAX
 1MHz TO 65MHz -0.5 dB MAX
 65MHz TO 100MHz -1.0 dB MAX

RET. LOSS (MIN) @ 100ΩHMS ±15%

0.5MHz-40MHz -18 dB
 40MHz-80MHz -12+20LOG(f/80MHz) dB

CM TO CM REJ

100kHz - 100MHz -30 dB MIN

CM TO DM REJ

100kHz - 100MHz -35 dB MIN

HIPOT (Isolation Voltage): 1500 Vrms

100% OF PRODUCTION TESTED TO COMPLY WITH IEEE 802.3 ISOLATION REQUIREMENTS.

LEDS 1, 2, 3 AND 4

VF (FORWARD VOLTAGE) IF=20mA GREEN 2.2V TYP.

LD (DOMINANT WAVELENGTH) IF=20mA GREEN 565nm TYP.

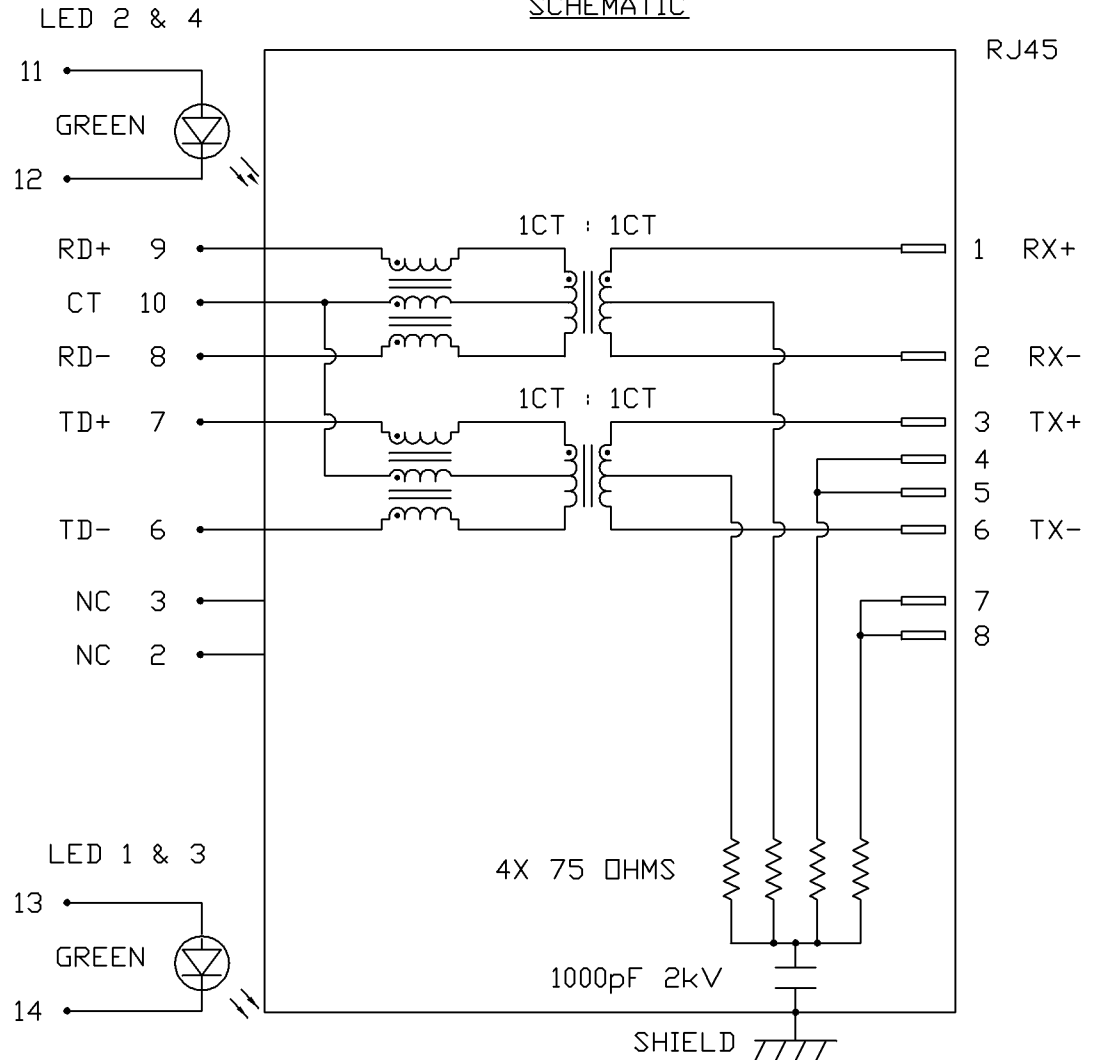

ORIGINATED BY	DATE	TITLE
CHOW WANCHUNG	01-13-09	2X6 MagJack® (COMPRESSOR SERIES)
DRAWN BY	DATE	
LEE WEIDE	01-13-09	

PART NO. / DRAWING NO.	STANDARD DIM. TOL. IN INCH	[] METRIC DIM. AS REFERENCE
C850-2G6R-M9	.X .XX .XXX	UNIT : INCH [mm] SCALE : N/A
FILE NAME	C850-2G6R-M9_PD.DWG	REV. : PD SIZE : A4 PAGE : 2

FILE NAME	STANDARD DIM. TOL. IN INCH	[] METRIC DIM. AS REFERENCE
C850-2G6R-M9_PD.DWG	.X .XX .XXX	UNIT : INCH [mm] SCALE : N/A
		REV. : PD SIZE : A4 PAGE : 2



THE INFORMATION CONTAINED HEREIN IS CONSIDERED "PROPRIETARY" TO BEL FUSE INC. AND SHALL NOT BE COPIED, REPRODUCED OR DISCLOSED WITHOUT THE WRITTEN APPROVAL OF BEL FUSE INC.

PRELIMINARY

RoHS
2002/95/EC

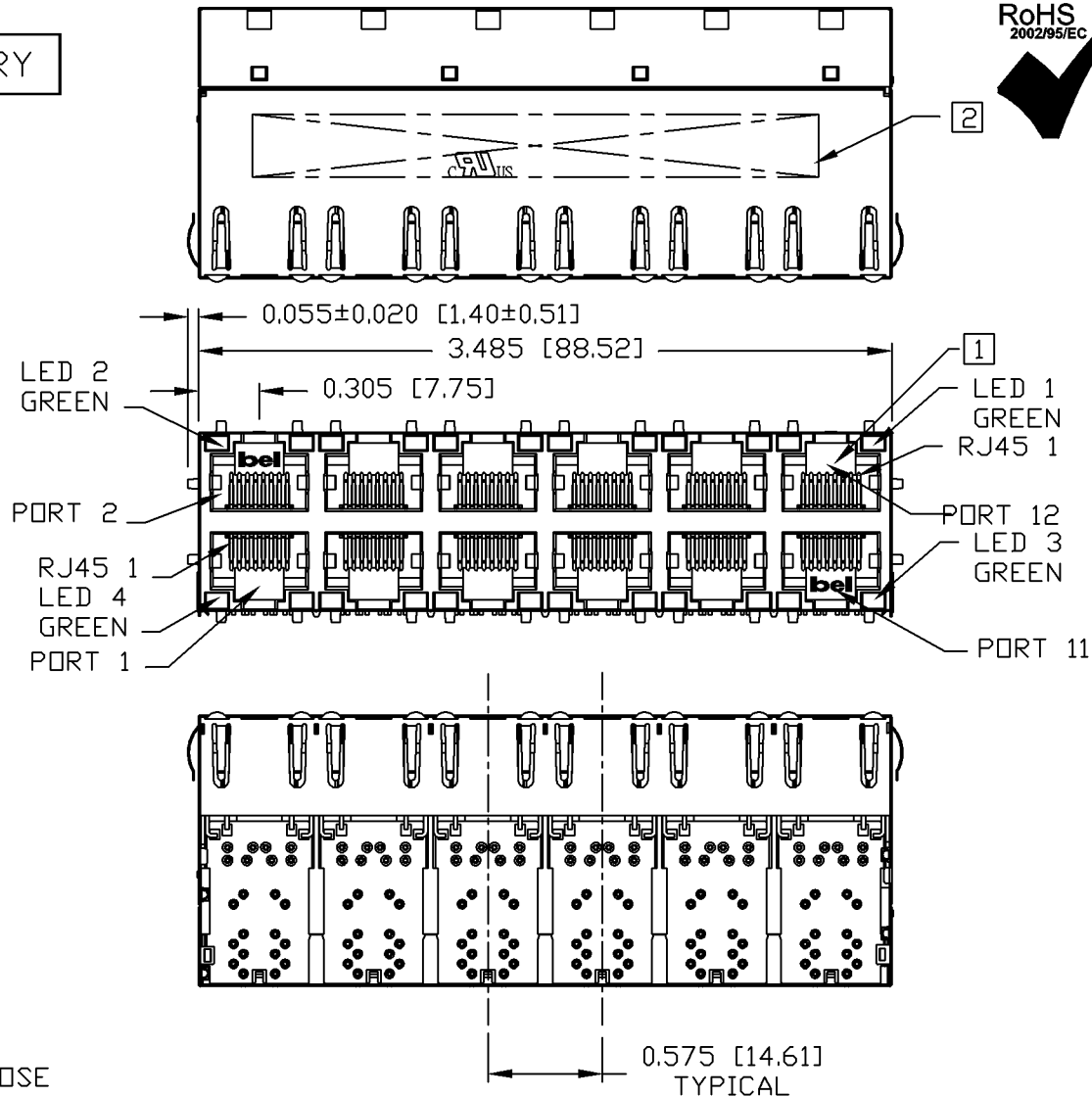
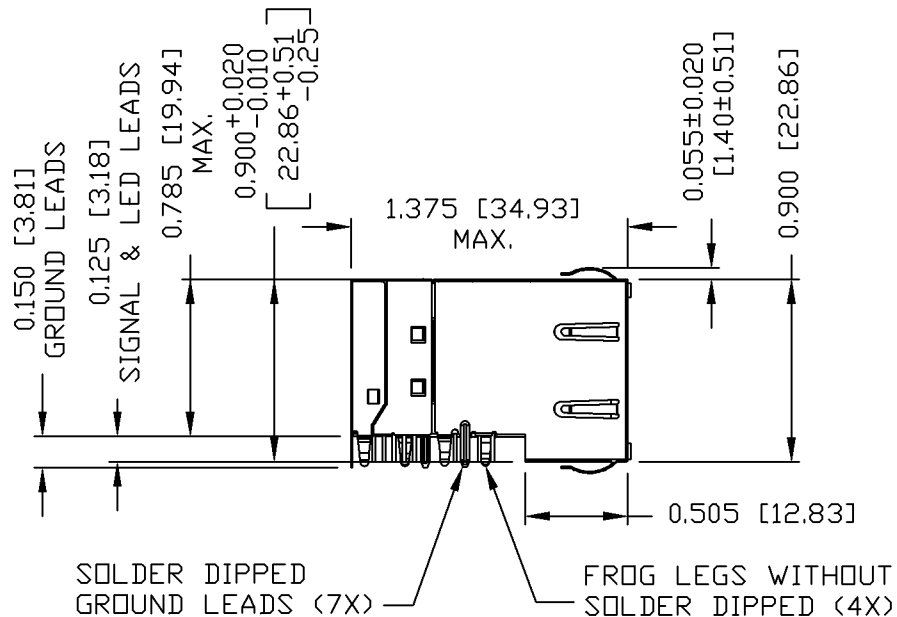

NOTES:

- PLASTIC HOUSING: THERMOPLASTIC PBT
FLAMMABILITY RATING UL 94V-0
- CONTACT PLATING: 30 MICRO-INCH HARD GOLD PLATING
- OUTPUT PINS: TIN-COATED COPPER WIRE, DIA 0.018 INCH.
- METAL SHIELD: NICKEL PLATED ON COPPER ALLOY,
(ALL GROUND LEADS ARE SOLDER DIPPED)
- FRDG LEGS ARE FOR PCB RETENTION
FORCE ONLY AND NOT FOR GROUNDING PURPOSE

- [1] JACK CAVITY CONFORMS TO FCC RULES AND REGULATIONS, PART 68 SUBPART F.
- [2] MARK PART WITH MFG LOGO, NAME, PART NUMBER AND DATE CODE.

RoHS COMPLIANCE, PER EU DIRECTIVE 2002/95/EC.
c us UL RECOGNIZED - FILE #E196366 AND E169987.

ORIGINATED BY	DATE	TITLE	PART NO. / DRAWING NO.	STANDARD DIM. TOL. IN INCH	[] METRIC DIM. AS REFERENCE	 COMPONENTS FOR A CONNECTED PLANET	
HOWFAR WEI	01-13-09	2X6 MagJack® (COMPRESSOR SERIES)	C850-2G6R-M9	.X	UNIT : INCH [mm]		REV. : PD
DRAWN BY	DATE		FILE NAME	.XX	SCALE : N/A		SIZE : A4
JOLLY LUD	01-13-09		C850-2G6R-M9_PD.DWG	.XXX	±0.010		PAGE : 3

THE INFORMATION CONTAINED HEREIN IS CONSIDERED "PROPRIETARY" TO BEL FUSE INC. AND SHALL NOT BE COPIED, REPRODUCED OR DISCLOSED WITHOUT THE WRITTEN APPROVAL OF BEL FUSE INC.

PRELIMINARY



PORT ASSIGNMENT
(COMPONENT SIDE VIEW)

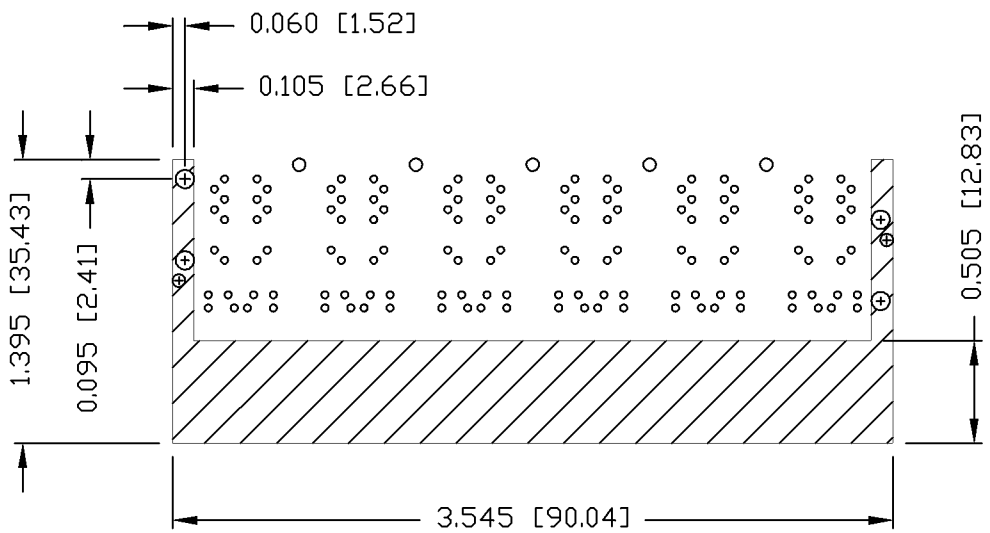
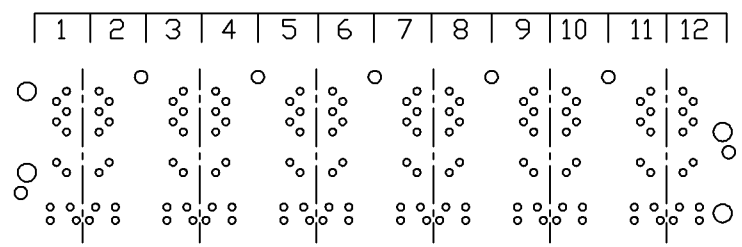

THE SHADED AREA ON THE CUSTOMER BOARD ARE RECOMMENDED TO BE CLEAR OFF ANY VIA HOLE OR COMPONENT PAD.

PIN-OUT INFORMATION
(COMPONENT SIDE VIEW)

10	CT
9	RD+
8	RD-
7	TD+
6	TD-
5	NO PIN
4	NO PIN
3	NC
2	NC
1	NO PIN

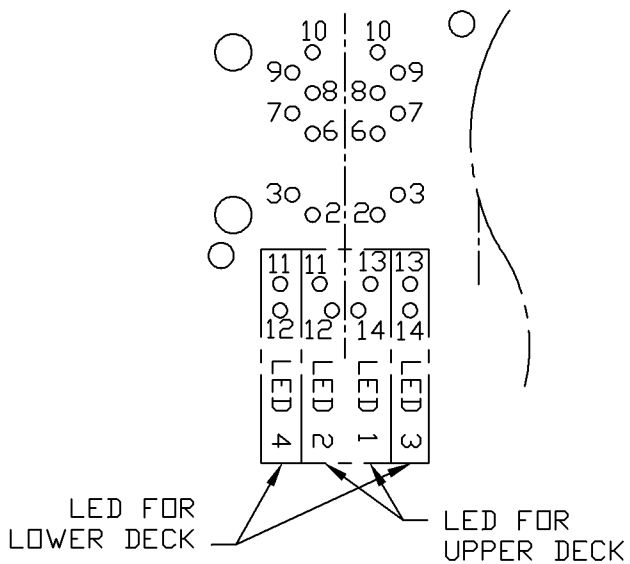

ORIGINATED BY HOWFAR WEI	DATE 01-13-09	TITLE 2X6 MagJack® (COMPRESSOR SERIES)	PART NO. / DRAWING NO. C850-2G6R-M9	STANDARD DIM. TOL. IN INCH	[] METRIC DIM. AS REFERENCE	 COMPONENTS OR A CONNECTED PLANET	
DRAWN BY JOLLY LUO	DATE 01-13-09		FILE NAME C850-2G6R-M9_PD.DWG	.X .XX .XXX	UNIT : INCH [mm] SCALE : N/A		REV. : PD SIZE : A4 PAGE : 4
				±0.004			

THE INFORMATION CONTAINED HEREIN IS CONSIDERED "PROPRIETARY" TO BEL FUSE INC. AND SHALL NOT BE COPIED, REPRODUCED OR DISCLOSED WITHOUT THE WRITTEN APPROVAL OF BEL FUSE INC.

PRELIMINARY

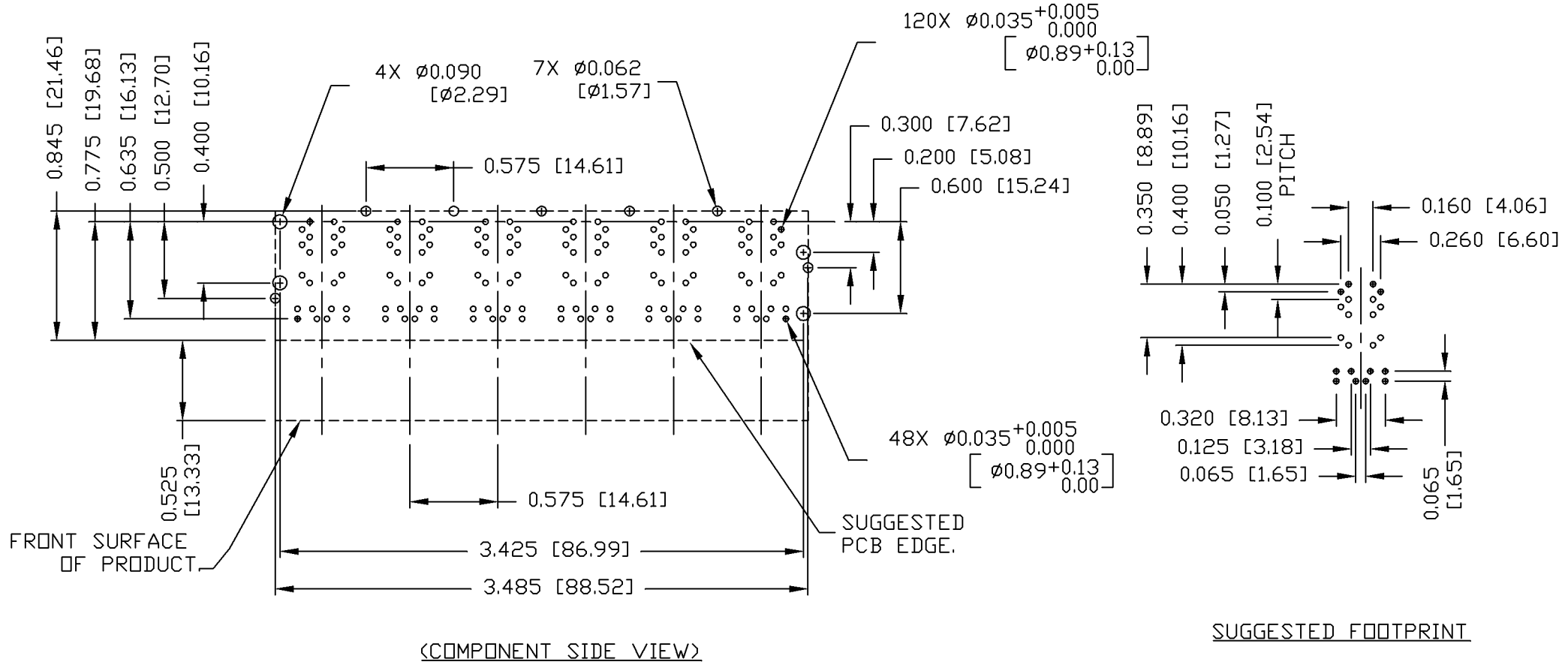

ORIGINATED BY HOWFAR WEI	DATE 01-13-09	TITLE 2X6 MagJack® (COMPRESSOR SERIES)	PART NO. / DRAWING NO. C850-2G6R-M9		STANDARD DIM. TOL. IN INCH		[] METRIC DIM. AS REFERENCE	
			FILE NAME C850-2G6R-M9_PD.DWG		.X .XX .XXX	±0.004	UNIT : INCH [mm] SCALE : N/A	REV. : PD SIZE : A4 PAGE : 5



THE INFORMATION CONTAINED HEREIN IS CONSIDERED "PROPRIETARY" TO BEL FUSE INC. AND SHALL NOT BE COPIED, REPRODUCED OR DISCLOSED WITHOUT THE WRITTEN APPROVAL OF BEL FUSE INC.

PRELIMINARY



SUGGESTED PANEL OPENING

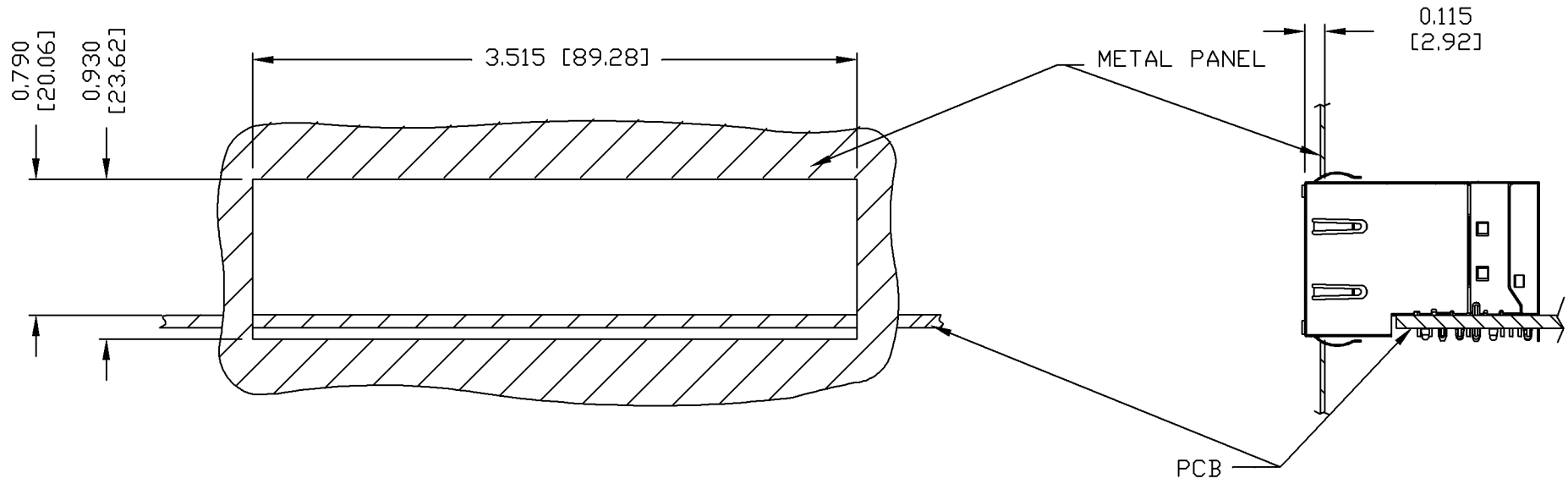

NOTE:
 THE DISTANCE OF PANEL INSIDE SURFACE RELATIVE TO FRONT SURFACE OF PART IS ONLY A SUGGESTION. IN CASE THIS DISTANCE IS DIFFERENT, THE REQUIRED PANEL OPENING DIMENSIONS CHANGE ACCORDINGLY.

PACKING INFORMATION

PACKING TRAY : 0200-9999-H1 (TOP)
 0200-9999-H2 (BOTTOM)
 PACKING QUANTITY : 18 PCS FINISHED GOODS PER TRAY.
 6 TRAYS (108 PCS FINISHED GOODS) PER CARTON BOX.
 NOTE : CARDBOARDS ARE PLACED BETWEEN LAYERS OF PACKING TRAY INSIDE CARTON BOX.
 (INCLUDE THE UPPERMOST AND LOWERMOST TRAY)

ORIGINATED BY HOWFAR WEI	DATE 01-13-09	TITLE 2X6 MagJack® (COMPRESSOR SERIES)	PART NO. / DRAWING NO. C850-2G6R-M9		STANDARD DIM. TOL. IN INCH		[] METRIC DIM. AS REFERENCE		bel COMPONENTS FOR A CONNECTED PLANET
			FILE NAME C850-2G6R-M9_PD.DWG		.X .XX .XXX	±0.004	UNIT : INCH [mm] SCALE : N/A	REV. : PD SIZE : A4 PAGE : 6	
DRAWN BY JOLLY LUO	DATE 01-13-09								