

THIS DRAWING AND THE SUBJECT MATTER SHOWN THEREON ARE CONFIDENTIAL AND THE PROPERTY OF BEL/STEWART/TRP CONNECTOR AND SHALL NOT BE REPRODUCED, COPIED, OR USED IN ANY MANNER WITHOUT THE WRITTEN CONSENT OF TRP CONNECTOR.

PRODUCT MAY BE PROTECTED BY ONE OR MORE OF THE FOLLOWING US PATENTS:
 5736910 5939955 6425781 6428361 6554638 6840817 7123117
 7429195 7717749 7808751 6217391 6149050 7924130

REVISIONS				
#	LT#	DESCRIPTION	DATE	APP'D
2		EC-1411035 COMPANY LOGO CHANGE	04JAN2015	DP TY

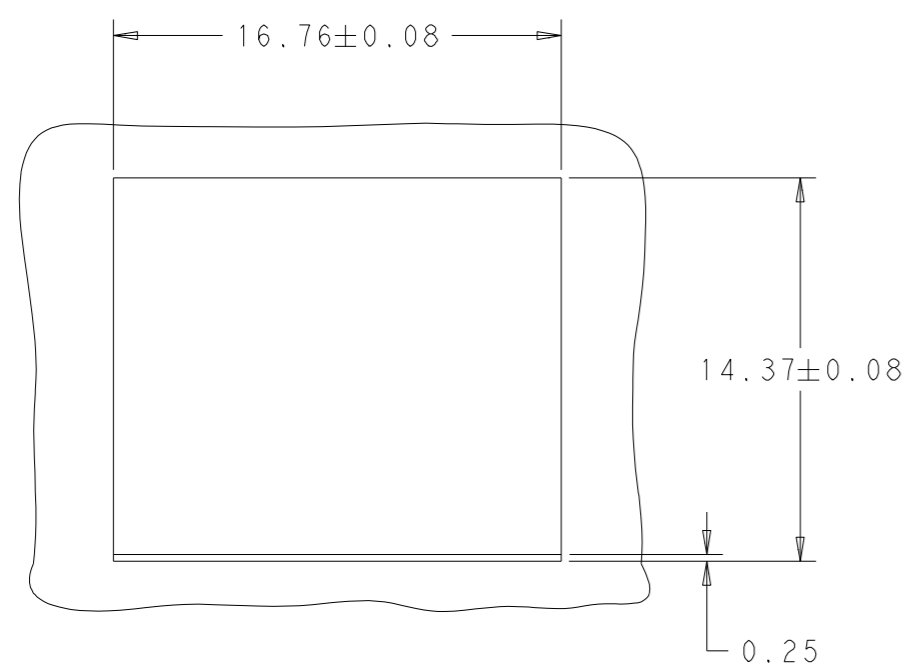
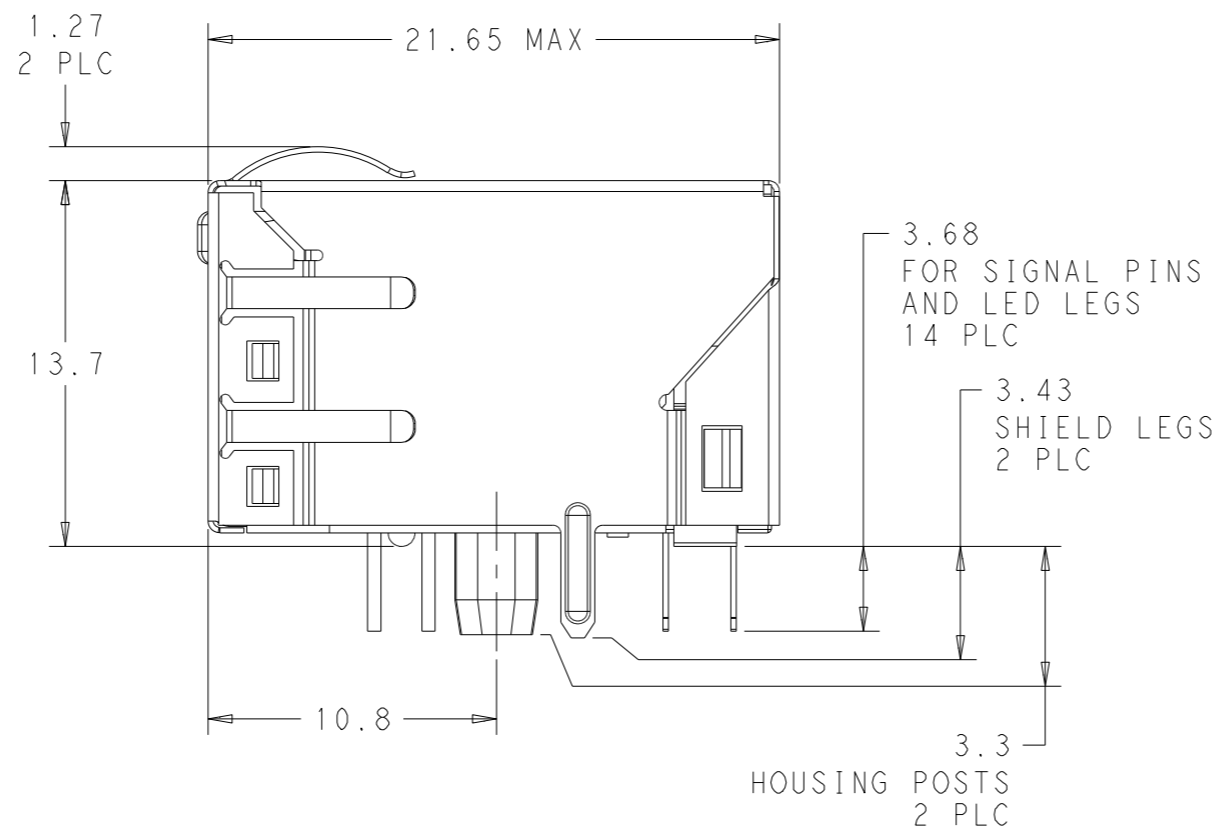
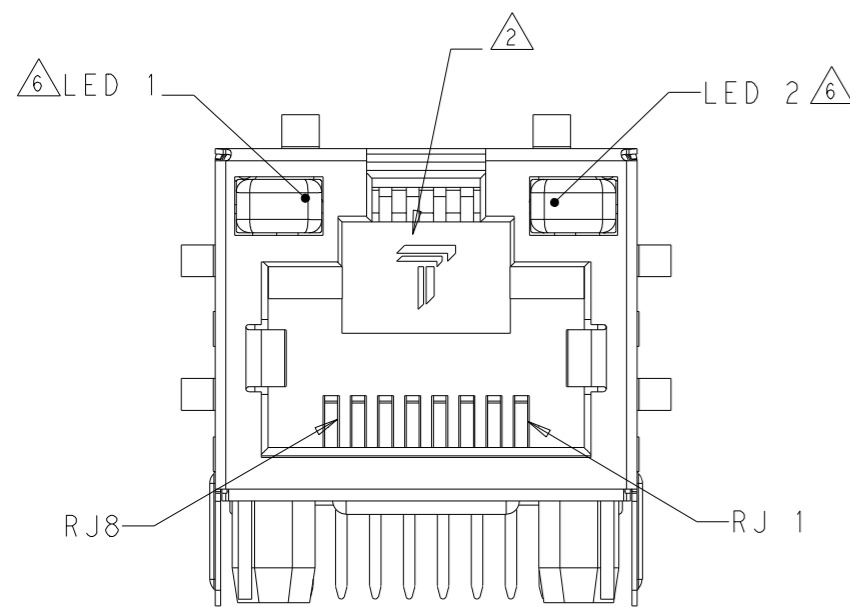
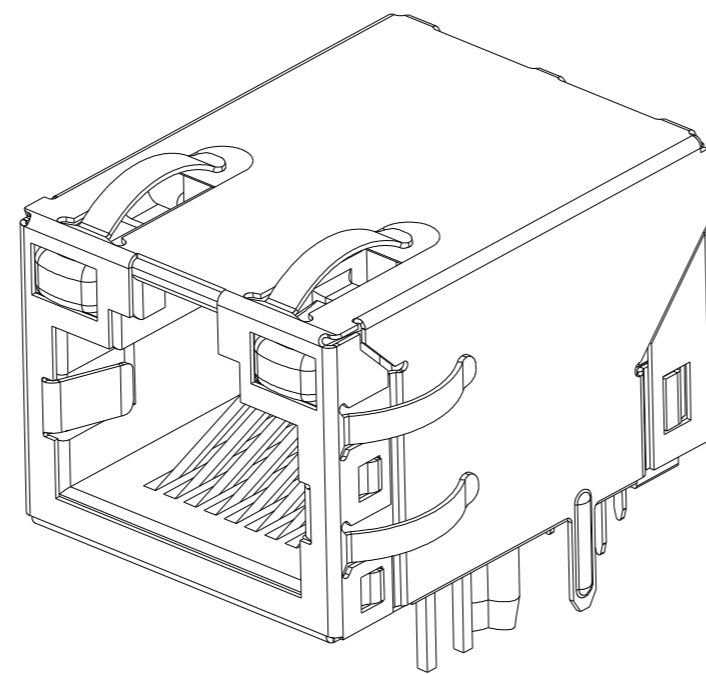
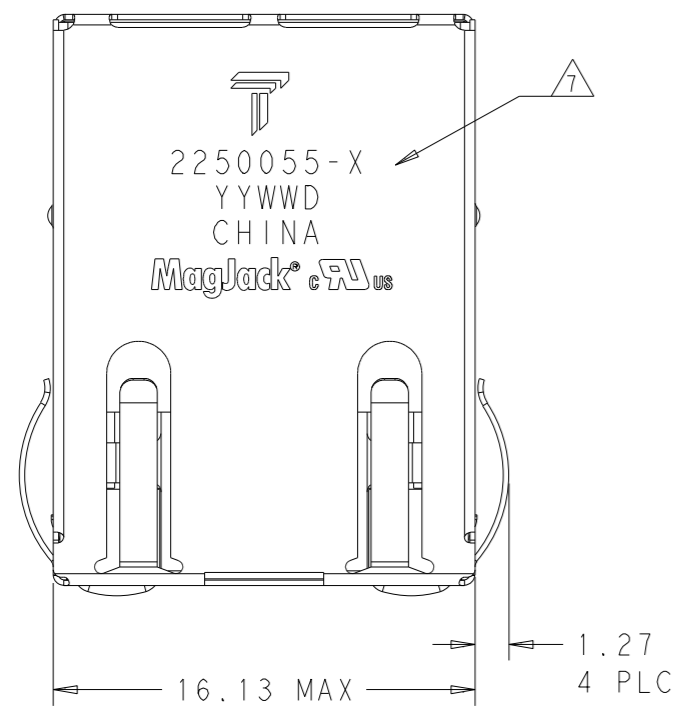

SUGGESTED CUT PANEL AND PCB

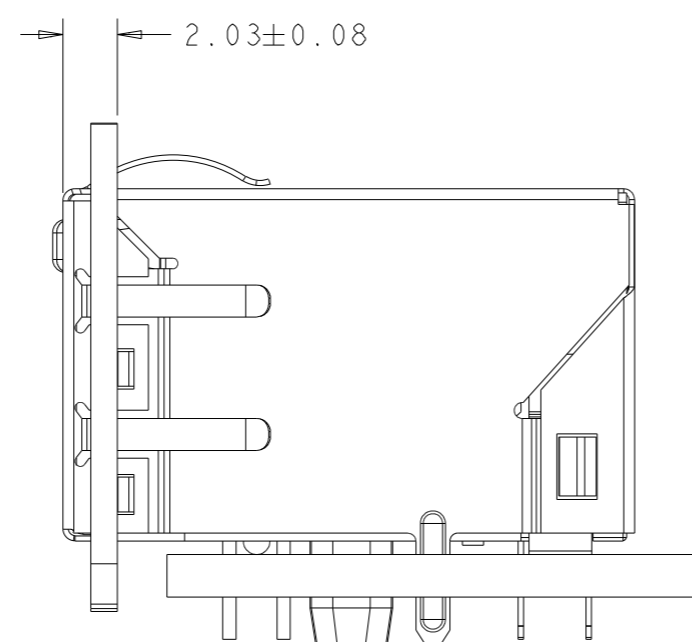

1. MATERIALS

- HOUSING: THERMOPLASTIC, FLAMMABILITY RATING UL 94V-0.
- SHIELD: BRASS 0.20mm THICK, PREPLATED WITH 0.76um MIN SEMI-BRIGHT NICKEL. SOLDER TABS POST DIPPED WITH 2.54um MIN SAC SOLDER.
- CONTACTS: PHOSPHOR BRONZE 0.46mm X 0.30mm, PHOSPHOR BRONZE, 1.27um MIN NICKEL UNDERPLATE, WITH 1.27um MIN GOLD PLATING AT MATING INTERFACE AND 2.54um MIN MATTE TIN ON SOLDER TAILS, OR 1.27um MIN NICKEL UNDERPLATE, WITH 0.05um GOLD PLATING OVER 0.76um MIN PALLADIUM NICKEL PLATING AT MATING INTERFACE AND 2.54um MIN MATTE TIN ON SOLDER TAILS.
- SOLDER TAILS: 0.25mm THICK, PHOSPHOR BRONZE, 1.27um MIN OVERALL NICKEL UNDERPLATE, 3um TIN PLATE
- LIGHT EMITTING DIODE (LED): DIFFUSED EPOXY LENS, 0.5mm X 0.5mm CARBON STEEL WIREFRAME LEADS PREPLATED WITH 2.03um MIN. SILVER PLATE OVER 1.02um MIN. NICKEL OVER 1.02um MIN. COPPER UNDERPLATE; LEADS POST-PLATED WITH 3.05um MIN. MATTE TIN AND/OR SAC SOLDER DIP OR PURE TIN SOLDER DIP

△ RJ45 JACK CAVITY CONFORMS TO FCC RULES AND REGULATIONS PART 68 SUB PART F.

△ MAGNETICS

- APPLICATION: 10/100 BASE-T, PoE
- IMPEDANCE: 100 OHMS
- TURNS RATIO (CHIP:CABLE): TX = 1:1, RX = 1:1
- OPEN CIRCUIT INDUCTANCE (OCL): 350uH MIN @100kHz, 0.1VRMS, 8mADC BIAS FROM 0°C TO 70°C, TX AND RX
- POE CURRENT: 350mADC MAX
- PERFORMANCE @ 25°C:
 - INSERTION LOSS (IL): 1.1dB MAX FROM 0.5MHz TO 100MHz
 - RETURN LOSS (RL): 18dB MIN FROM 0.5MHz TO 30MHz
 - 18-20LOG(f/30)dB MIN FROM 30.1MHz TO 60MHz
 - 12dB MIN FROM 60.1MHz TO 80MHz
 - CROSSTALK ATTENUATION: 35dB MIN FROM 0.5MHz TO 40MHz
 - 33-20LOG(f/50)dB MIN FROM 40.1MHz TO 100MHz
 - COMMON MODE REJECTION RATIO (CMRR): 30dB MIN FROM 0.5MHz TO 100MHz
- ISOLATION VOLTAGE: 2250VDC FOR 60 SECONDS WITH A RISE TIME OF 500 V/SEC

4. OPERATING TEMPERATURE: FROM 0°C TO 70°C.

△ INDICATED MAGNETIC CONNECTIONS ARE SYMMETRICAL TO SUPPORT AUTO-MDI/MDIX.

△ LEDS WITH BUIL-IN 250 OHM RESISTORS. LEDS ARE DRIVEN WITH 5V VOLTAGE AND THE MAX OPERATING CURRENT IS 20mA
 LED COLOR: DOMINATE WAVELENGTH (λD): GREEN 568 nm TYP. @ VF=5V
 FORWARD CURRENT (IF): GREEN 12mA TYP @ VF = 5V
 DOMINATE WAVELENGTH (λD): YELLOW 588 nm TYP. @ VF=5V
 FORWARD CURRENT (IF): YELLOW 13mA TYP @ VF = 5V

△ TRP CONNECTOR LOGO, PART NUMBER, DATE CODE, COUNTRY OF ORIGIN AND AGENCY APPROVAL MARKING IN APPROXIMATE LOCATION SHOWN. DATE CODE: YYWW WHERE YY IS YEAR, WW IS WORK WEEK, D IS DAY OF WEEK, WITH SUNDAY=1.

8. PART SHOULD BE RECOMMENDED FOR WAVE SOLDERING PROCESS, PREHEAT TEMPERATURE IS 120°C TO 160°C, 120 SECONDS TO 180 SECONDS, PEAK WAVE SOLDERING TEMPERATURE IS 260°C MAX, 10 SECONDS MAX.

YELLOW	GREEN	2250055-1
11 → 12	13 → 14	PART NUMBER
LED 1	LED 2	

THIS DRAWING IS A CONTROLLED DOCUMENT.		OWN: ROY LIU 06 JUN 2013	 DONGGUAN CHINA
DIMENSIONS: mm	TOLERANCES UNLESS OTHERWISE SPECIFIED:	CHK: TOWER YU / FRANK LIU 06 JUN 2013	
0 PLC ±0.25 1 PLC ±0.25 2 PLC ±0.25 3 PLC ±0.25 4 PLC ± ANGLES ± APPLICATION SPEC	MODEL NAME: MAGJACK SINGLE PoE DESC: 1X1 7U26L 10/100 POE TAB UP W/ LED SIZE: A1 SCALE: 3:1 SHEET: 1 OF 3 REV: 2	APD: TONY YUAN 06 JUN 2013 CUSTOMER DRAWING	

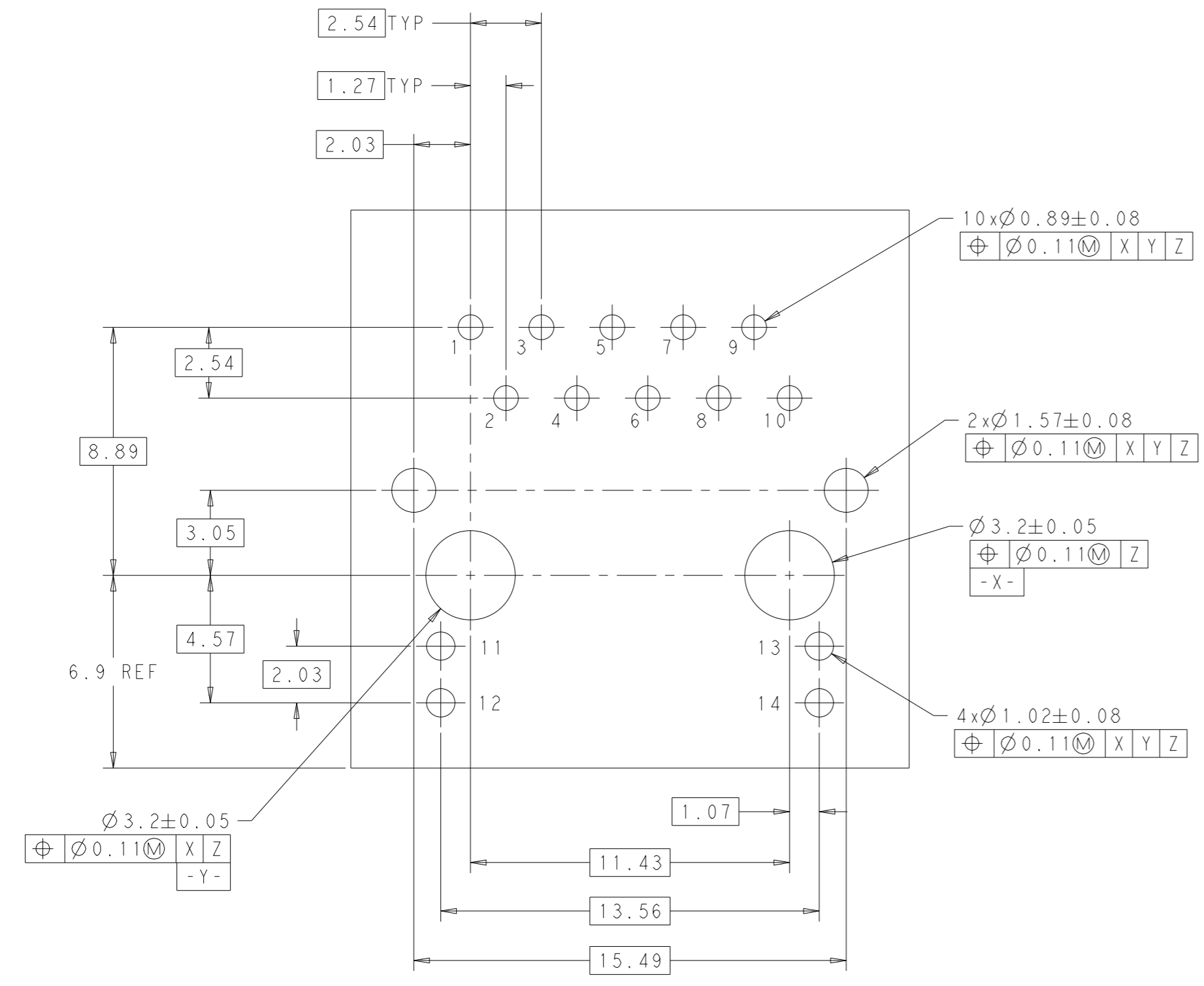

SUGGESTED CUSTOMER BOARD LAYOUT
 (COMPONENT SIDE)

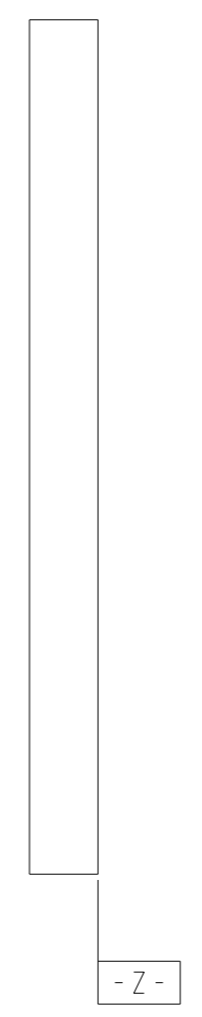

7U26L MAGNETIC CIRCUIT $\triangle \triangle$

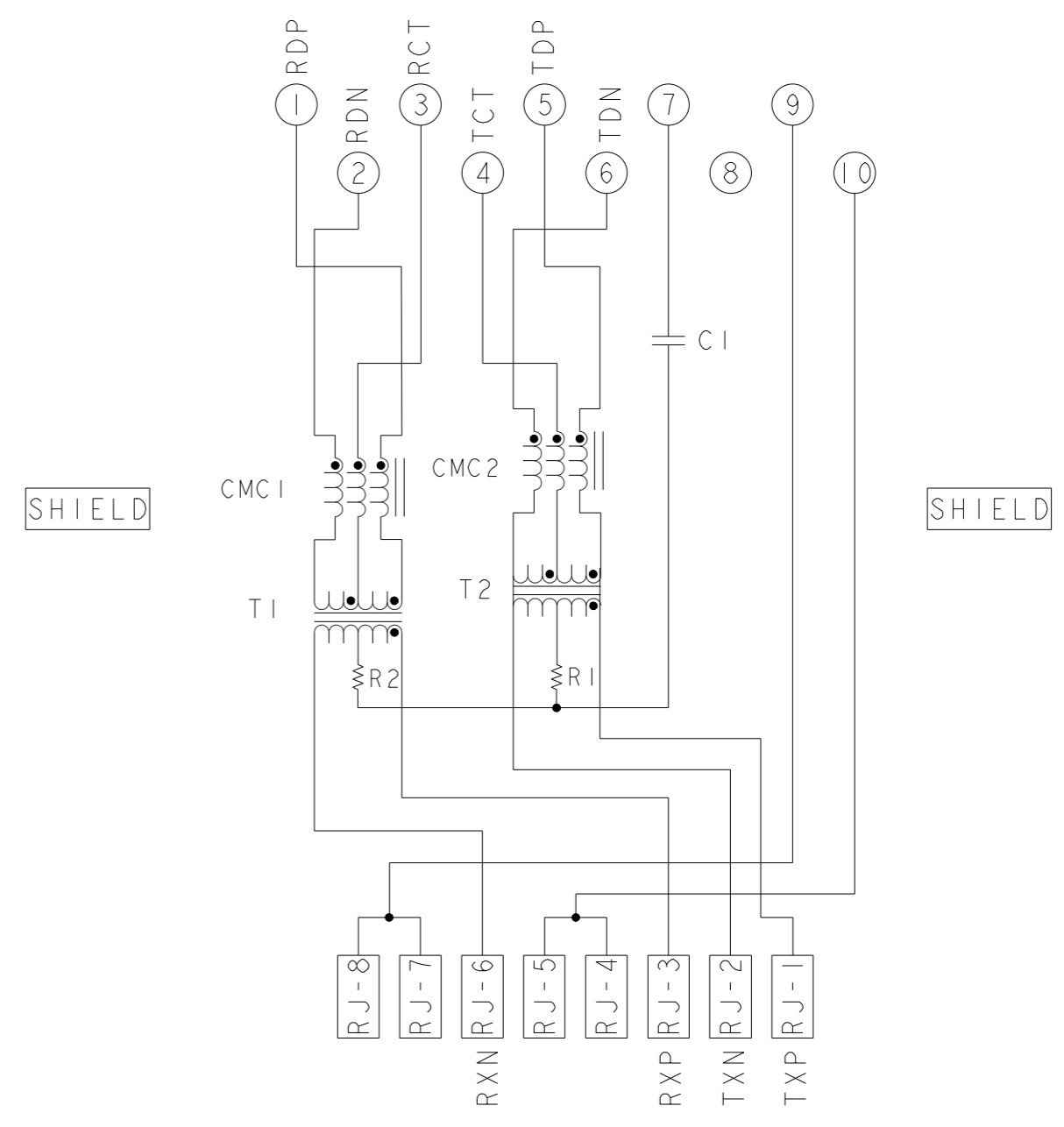

C1 = 1000 pF, 2kV CAPACITOR
 R1-R2 = 75 OHMS, RESISTORS

THIS DRAWING IS A CONTROLLED DOCUMENT.		DWN ROY LIU 06 JUN 2013	 DONGGUAN CHINA
DIMENSIONS: mm		CHK TOWER YU / FRANK LIU 06 JUN 2013	
TOLERANCES UNLESS OTHERWISE SPECIFIED:		APPR TONY YUAN 06 JUN 2013	
0 PLC ± 0.25 1 PLC ± 0.25 2 PLC ± 0.25 3 PLC ± 0.25 4 PLC ± 0.25 ANGLES \pm APPLICATION SPEC \pm		MODEL NAME MAGJACK SINGLE PoE	
PRODUCT SPEC	APPLICATION SPEC	DESC 1X1 7U26L 10/100 POE TAB UP W/ LED	RESTRICTED TO
CUSTOMER DRAWING		SIZE A1	SCALE 3:1
		DRAWING NO C=2250055	SHEET 2 OF 3
		REV 2	

C_2250055					STOCK DISPOSITION			
					A: CONTINUE AS IS B: REWORK C: SCRAP		D: USE OLD FIRST E: PARTS TO CONFORM F: OTHER	
REVISION HISTORY								
DATE	REV	CHANGES	REASON	APPROVAL	INVENTORY (A,B,C,D,E,F)	WORK IN PROCESS (A,B,C,F)	SUPPLIER ORDERS (A,E,F)	OPEN CUST ORDERS (A,E,F)
06JUN2013	1	-	INITIAL RELEASE	TONY YUAN	-	-	-	-
04JAN2015	2	EC-1411035 COMPANY LOGO CHANGE	MARKET REQUEST	TONY YUAN	-	-	-	-

THIS DRAWING IS A CONTROLLED DOCUMENT.

DIMENSIONS: mm	TOLERANCES UNLESS OTHERWISE SPECIFIED: 0 PLC ±0.25 1 PLC ±0.25 2 PLC ±0.25 3 PLC ±0.25 4 PLC ± ANGLES ±	DWN ROY LIU 06 JUN 2013 CHK TOWER YU/ FRANK LIU 06 JUN 2013 APVD TONY YUAN 06 JUN 2013 MODEL NAME MAGJACK DESC IXI 7U26L 10/100 POE TAB UP W/ LED SIZE A1 CAGE CODE DRAWING NO. C=2250055 RESTRICTED TO - CUSTOMER DRAWING SCALE 3:1 SHEET 3 OF 3 REV 2
-------------------	---	--



trp CONNECTOR DONGGUAN CHINA
a bel group